

MHI
Copy 3

FM 5-20

DEPARTMENT OF THE ARMY FIELD MANUAL

CAMOUFLAGE BASIC PRINCIPLES AND FIELD CAMOUFLAGE



HEADQUARTERS, DEPARTMENT OF THE ARMY
JANUARY 1959

FIELD MANUAL }
 No. 5-20 }

HEADQUARTERS,
 DEPARTMENT OF THE ARMY
 WASHINGTON 25, D. C., 21 January 1959

CAMOUFLAGE, BASIC PRINCIPLES AND FIELD CAMOUFLAGE

	Paragraphs	Page
PART ONE. BASIC PRINCIPLES OF CAMOUFLAGE		
CHAPTER 1. INTRODUCTION	1-5	3
2. THE PROBLEM OF CONCEALMENT		
Section I. Types of observation.....	6, 7	6
II. Types of photographs.....	8, 9	10
III. Preventing recognition.....	10, 11	14
CHAPTER 3. PRINCIPLES AND METHODS OF CAMOUFLAGE	12, 13	24
4. GEOGRAPHIC FACTORS		
Section I. Temperate zone.....	14, 15	32
II. Desert.....	16, 17	32
III. Jungle.....	18, 19	36
IV. Snow and ice.....	20-23	38
CHAPTER 5. USE OF NATURAL AND ARTIFICIAL MATERIALS		
Section I. Natural materials and their uses.....	24, 25	42
II. Artificial camouflage materials and their use.....	26-36	45
III. Maintenance of natural and artificial materials.....	37, 38	55
IV. Disruption of form.....	39-41	55
PART TWO. FIELD CAMOUFLAGE		
CHAPTER 6. INDIVIDUAL CAMOUFLAGE	42-54	59
7. FIELD FORTIFICATIONS		
Section I. Emplacements.....	55-57	79
II. Individual weapons.....	58, 59	93
CHAPTER 8. VEHICLES	60-71	96
9. BIVOUACS, COMMAND POSTS, AND FIELD SERVICE INSTALLATIONS	72-81	110
10. ANTI-AIRCRAFT ARTILLERY, FIELD ARTILLERY, AND GUIDED MISSILE INSTALLATIONS		
Section I. Antiaircraft artillery and field artillery.....	82-92	137
II. Guided missile.....	93-97	157
CHAPTER 11. AIRFIELDS, LANDING SITES, AND AIRCRAFT		
Section I. Airfields and landing sites.....	98-100	164
II. Camouflage of aircraft.....	101-115	187

*This manual supersedes FM 5-20 9 February 1944; FM 5-20A, 9 February 1944; FM 5-20B, 2 April 1944; FM 5-20C, 1 May 1944; FM 5-20D, 9 February 1944, including C 1, 14 January 1955; FM 5-20E, 1 June 1944; and FM 5-20F, 1 May 1944, including C 1, 17 January 1955.

	Paragraphs	Page
CHAPTER 12. FIELD EXPEDIENTS.....	116-118	204
APPENDIX I. REFERENCES.....		226
II. TECHNICAL INFORMATION AND DATA ON INDIVIDUAL DRAPE NETS AND DRAPE NET SETS.....		227
INDEX.....		247

PART ONE
BASIC PRINCIPLES OF CAMOUFLAGE
CHAPTER 1
INTRODUCTION

1. Purpose

This manual provides guidance for military personnel on camouflage doctrine and on methods of applying camouflage in the field.

2. Scope

a. The manual covers the three basic principles of camouflage; factors of recognition, geographic factors effecting camouflage, and camouflage methods. It describes methods of applying camouflage in the field and suggests expedients that may be used in camouflaging the following: Individuals, weapons, vehicles, aircraft, anti-aircraft and field artillery, guided missile firing positions and installations, pioneer and hasty airfields, landing sites, bivouacs, supply points, field fortifications, and other objects and installations. In addition, information on camouflage nets and net sets, drape-type, including component parts listings and erection procedures is covered.

b. The introduction of nuclear weapons onto the battlefield poses many new problems and imposes many new requirements on both individuals and commanders. Nuclear weapons will be used against those targets which appear to be most remunerative. The best means of reducing the chance of a unit becoming the target of nuclear attack is to deny the enemy information as to the unit location and strength, or to fool the enemy by deception. Habitual use of proper camouflage will greatly assist in denying this information to the enemy. This manual describes the basic principles and the methods for the effective use of camouflage to deny essential target information to the enemy. The material presented herein is applicable to both nuclear and nonnuclear warfare.

3. General

a. Camouflage is a French word meaning disguise and is used to describe actions taken to mislead the enemy by misrepresenting the true identity of an installation, an activity, or an item of equipment.

Camouflage, as an element of military deception, permits us to approach unseen and to remain hidden within striking distance of the enemy. It also affords protective concealment for a firing position, material, and personnel. Camouflage permits the individual to see without being seen, thereby enabling him to strike first, conclusively and at minimum cost.

b. Camouflage uses concealment and deception to promote our offensive or defensive action, to surprise, to mislead the enemy, and to prevent the enemy from inflicting damage. Concealment includes hiding from view, making hard to see clearly, arranging obstructions to vision, deceiving, and disguising. It also enhances deception by means of sound. Concealment and deception provide the tools to lure the enemy into a trap, or to place himself in a position of disadvantage, where he can be quickly and easily destroyed.

4. Camouflage as a Tactical Aid

a. Dispersion as a Means of Camouflage. Dispersion must become a key word and action for the individual soldier. The natural but extremely dangerous tendency to "bunch up" is to be avoided. Once observed, any concentration of men or material, or both, immediately presents a prime target for the enemy.

b. Factors in Dispersion. When subject to hostile aerial observation or upon establishing contact with enemy ground forces, a unit commander disperses his troops. When taking up a position or preparing to build an installation of any sort that may risk becoming a potential target to the enemy, he also disperses its various elements to the fullest extent, dependent on the tactical situation. By taking these security measures two things are accomplished. First, it permits men and material from presenting a profitable target. Second, they become more difficult to see. The governing factors in dispersion are the tactical situation, the nature of the terrain, and the control of troops.

c. Detection by the Enemy. Even when a position is perfectly camouflaged or completely concealed by the natural protection of woods or other terrain features, the possibility of the eventual detection by the enemy must be taken into consideration. Except for the use of natural concealment afforded by wooded areas, trees, bushes, and terrain features, proper dispersion of a command offers the most convenient short cut to successful camouflage. If the troops or installation cannot be seen, they are difficult to hit. However, even though the enemy may be able to see the position, camouflage is still used to prevent him from recognizing it. Even if the enemy could recognize it, camouflage would be used to prevent him from estimating how large an installation it was and how many troops comprise it. The first aim of camouflage is to hide an object, men, or equipment

and the first step in hiding is to break a large group up into many small units which are harder to see individually and also easier to conceal. This dispersion is important for two additional reasons. First, it is more difficult to hit one small object than a group. Second, a single unit is less valuable a target. One tent, one tank, or one man may escape attack if the enemy is looking for bigger and better targets where he can do more damage.

d. Deception as an Element of Camouflage. The second aim of camouflage is deception. This is attained by the use of any means or measure to mislead, distract, or misrepresent any installation, equipment, or activity. Deception is covered in FM 5-23.

5. Responsibility for Camouflage

a. Individual. The individual soldier is responsible for individual concealment. The soldier must know as much about individual concealment as he does about his weapon. Rifle marksmanship teaches him how to hit enemy targets; camouflage teaches him to avoid becoming a target himself. The concealment of the area is also vital to individual safety and is maintained through strict camouflage discipline.

b. Staff. Camouflage planning is an important phase of counter-intelligence activities and as such may be delegated to the staff engineer under the general staff supervision of the intelligence section. Plans for area camouflage are coordinated with the operations sections for operational planning and with the staff supply or logistics section for the necessary materials.

c. Corps of Engineers. The Corps of Engineers is the Army technical service responsible for camouflage doctrine; the development of camouflage methods, materials, and supply; and the organization of Army-wide training in procedures, discipline, supervision, and inspection. The Corps of Engineers may be required to provide camouflage support for the Air Force. The nature of this camouflage support is primarily in the form of technical assistance.

CHAPTER 2

THE PROBLEM OF CONCEALMENT

Section I. TYPES OF OBSERVATION

6. General

Of man's five perceptive senses, sight is by far the most useful to the enemy; hearing is second; while smell is of only occasional importance. The comparative usefulness of the perceptive senses is primarily a matter of range. For this reason, basic camouflage stresses visual concealment which is relatively long range while sound camouflage is covered only briefly. Most persons are accustomed to looking from one position on the ground to another position on the ground. Before the soldier can conceal himself from aerial observation, he must become familiar with what his activities look like from the air, both in an aerial photograph and from direct observation. Also, the soldier must have an understanding of the types of observation used by the enemy. There are two categories of observation, direct and indirect.

a. Direct Observation. Direct observation refers to the process whereby the observer looks directly at the object itself, with or without the use of telescopes, field glasses, or sniperscopes (fig. 1). Direct observation may be made from the ground or from the air. Direct aerial observation becomes more and more important because of rapid



Figure 1. Direct observation.

changes in the tactical situation due to greater mobility of troops, weapons, and possible use of guided missiles by enemy forces. Reconnaissance airplanes over enemy lines report locations of troops, vehicles, and installations as seen from the air to the ground control stations. Immediate fire can be brought onto targets thus found and reported.

b. Indirect Observation. Indirect observation refers to the use or study of a photograph or an image of the subject (fig. 2). Photog-



Figure 2. Indirect observation, aerial photo.

raphy, radar, and television are examples of indirect observation. This form of observation is becoming increasingly more varied and rapid, and may be used from either manned or unmanned positions.

7. Comparison of Direct and Indirect Observation

a. The principal advantage of direct observation is that the observer can readily see movement of troops or equipment in the observed area and observation can be maintained over relatively long periods of time. The main disadvantage lies in human frailty, such as the physical condition of the individual affecting his power of observation.

b. The advantages of indirect observation are many. Indirect observation can be far reaching, cover large areas, and can be very accurate. It also produces a record of the area observed so that the recorded picture can be studied in detail, compared, and evaluated. The principal disadvantage is that a photograph covers a very short period of time, making detection of movement difficult. This disadvantage can be overcome partially by taking pictures of the same area at different intervals and comparing them for changes (1 and 2, fig. 3).

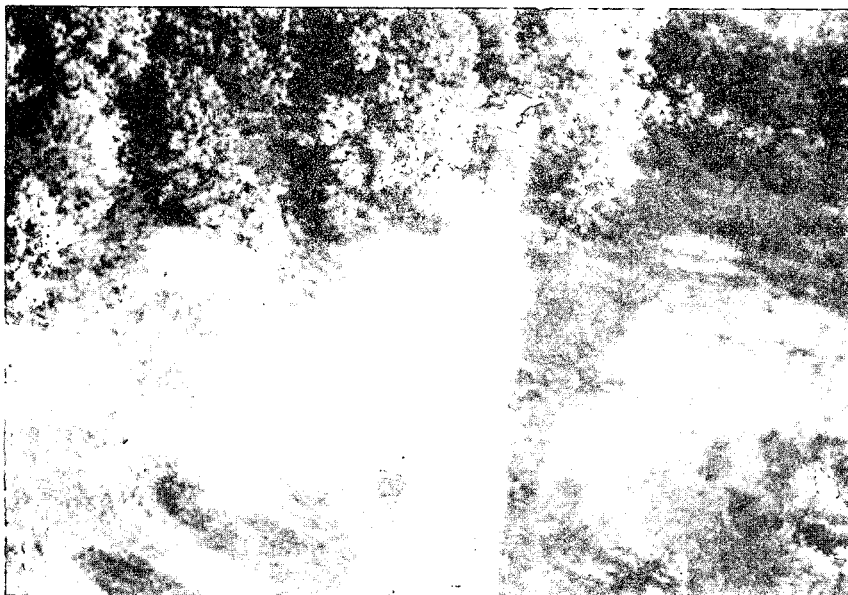

1

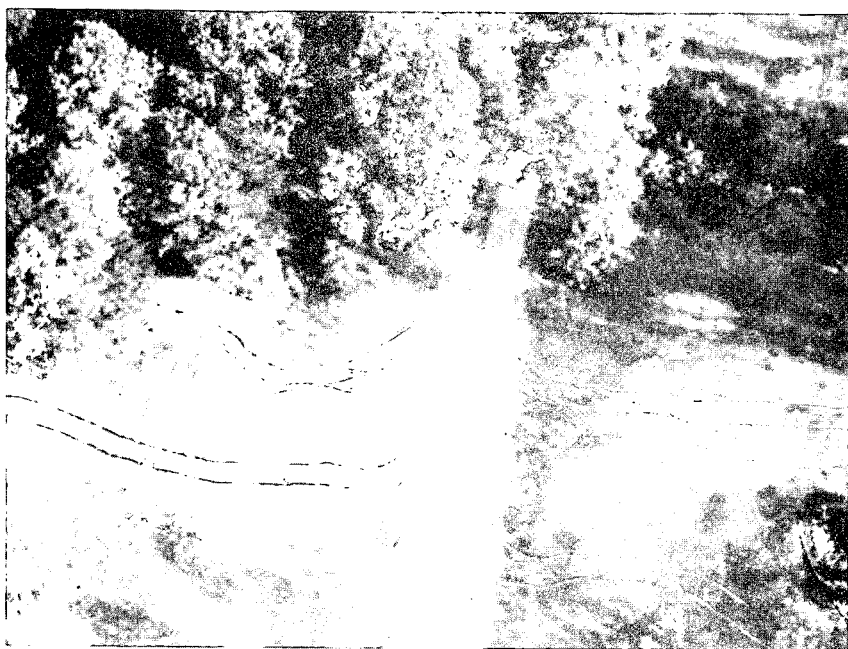

2

1 Area before occupation

2 Area after occupation

Figure 3. Comparing photographs of the same area for enemy activity.

Section II. TYPES OF PHOTOGRAPHS

8. General

a. *Angles of View.* In modern day warfare, photography (indirect observation) has assumed a place of extreme importance; in camouflage detection and inspection, photography is now practically indispensable. Aerial photographs are of three types.

- (1) *Vertical.* The vertical photograph is one taken directly above the subject (fig. 4). It shows practically no details in the third dimension other than shadow. It may compare to the plan view of a building on a blueprint. When taking a vertical photograph, the line of sight of the camera is perpendicular or nearly so to the line of flight of the airplane.

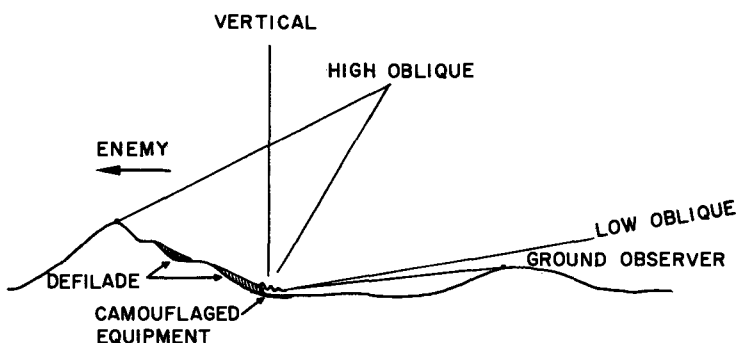

Figure 4. Diagram illustrating angles of view.

- (2) *High oblique.* This type of photograph shows the horizon and gives an idea of the third dimension by giving the side and the top view of the subject (fig. 4).
- (3) *Low oblique.* The low-oblique photograph is similar to the high-oblique except that it does not show the horizon (fig. 4).

b. *Stereovision.* In photo interpretation the process of stereovision is used extensively. By using two photographs of the same subject taken at slightly different angles (stereoscopic pairs) and viewing them with the assistance of stereoscopic lens, the third dimension (depth) can be seen. In military aerial photography the apparent depth is exaggerated because of the distance traveled by the aircraft between successive photographs. This magnification of vertical dimension permits an observer to detect elevation differences not detectable by the unaided vision. Normally, photographic coverage of an area that is to be studied will provide a minimum of 60 percent overlap to permit stereoscopic analysis with these stereoscopic pairs. This is of great advantage when examining enemy camouflage construction

or when inspecting our own camouflage construction. For further information on stereovision see FM 21-26.

c. Lenses. Cameras used in aerial photography may be equipped with different type lenses. The lens may be a normal-angle lens, wide-angle lens, narrow-angle lens, or telephoto lens depending on the scale, increased or decreased ground coverage, or depth perception qualities needed in the photograph by the photo interpreter.

9. Types of Film

Different types of film have been developed for use in aerial photography. The following four types of film for photography camouflage detection are available:

a. Black and White Film. The most common film in use today is the ordinary black and white film (1, fig. 5). This film records

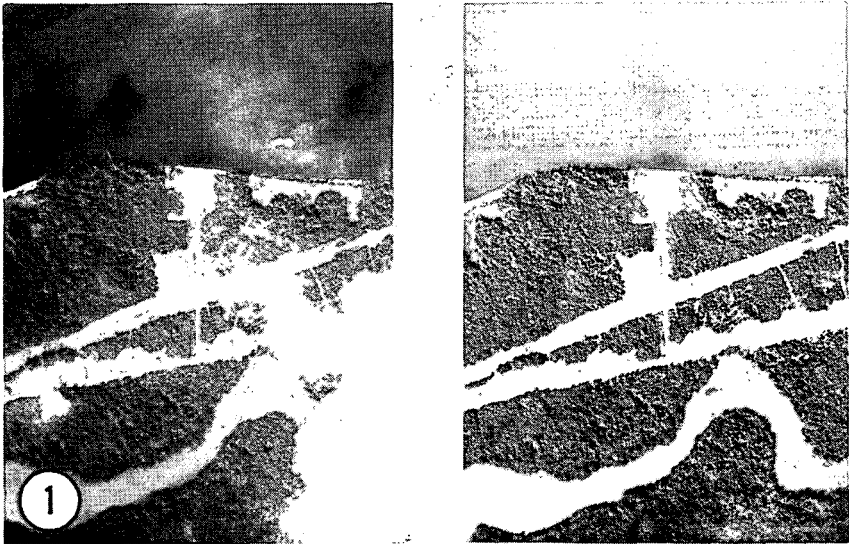

1 Black and white

Figure 5. Types of film.

images in tone gradation of gray between white and black. Although its sensitivity is different than the eye and does not reproduce color it provides a permanent record of tonal differences subject to prolonged study. Select filters are often used to improve the photograph or to record only the light that is known to give the greatest tonal differences between natural backgrounds and the object being sought.

b. Color Film. Color film approaches the sensitivity of the eye (2, fig. 5). However, owing to its chemical makeup and its principle of operation, this film will give best results only under ideal conditions



2 Color film

Figure 5—Continued.

(sunlight). The advantage of using color film is twofold. First, it provides color contrasts in addition to tonal contrasts, and second because the film is slightly different in sensitivity to the eye it often reveals camouflage by recording color differences not discernible to the unaided eye.

c. Infrared Film. Infrared film (3, fig. 5) is sensitive to radiation which has the same properties as light but which is of wave lengths that are not detectable by the human eye. However, photographic film identified as infrared-type film is sensitive to these wave lengths.

Therefore infrared photographs may be made of objects and terrain utilizing these wave lengths of radiation exclusively by filtering out the visible wave lengths of light. This film has many advantages in that it can be used to take photographs in darkness, provided there is a source of infrared radiation. Of particular advantage to camouflage detection is the fact that living green vegetation reflects the infrared waves very readily and in great quantities. This characteristic enables photographs of an area to be taken which provide pictures showing contrasting tones between living green vegetation and artificial plants and materials. However, camouflage infrared reflective paints have been developed that curb this advantage considerably.

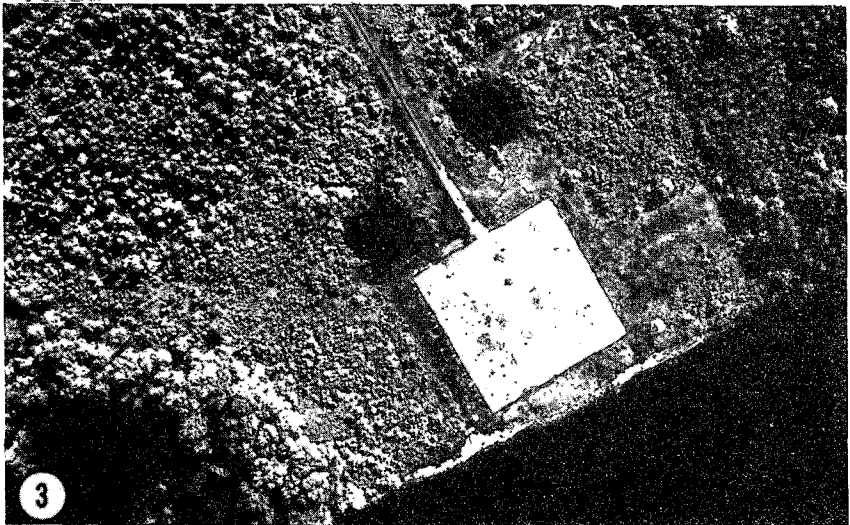

3 Infrared film

Figure 5—Continued.

d. Camouflage-Detection Film. Camouflage detection is a color film in which the sensitivity has been altered from recording blue, green and red light to recording green, red, infrared radiations (4, fig. 5). Since live green plant life has a particular and consistent relative reflection of these radiations, the film is so made as to reproduce an image of live plant life as red. All other combinations of reflection are recorded as some other color. Thus camouflage which does not have the same reflectance characteristics will be reproduced in some other color than red in the photograph; usually green or blue green. A photo interpreter trained in the use of this film is better able to detect camouflaged positions because of the high color contrast of the position and its background when the position is situated in an area of living vegetation.

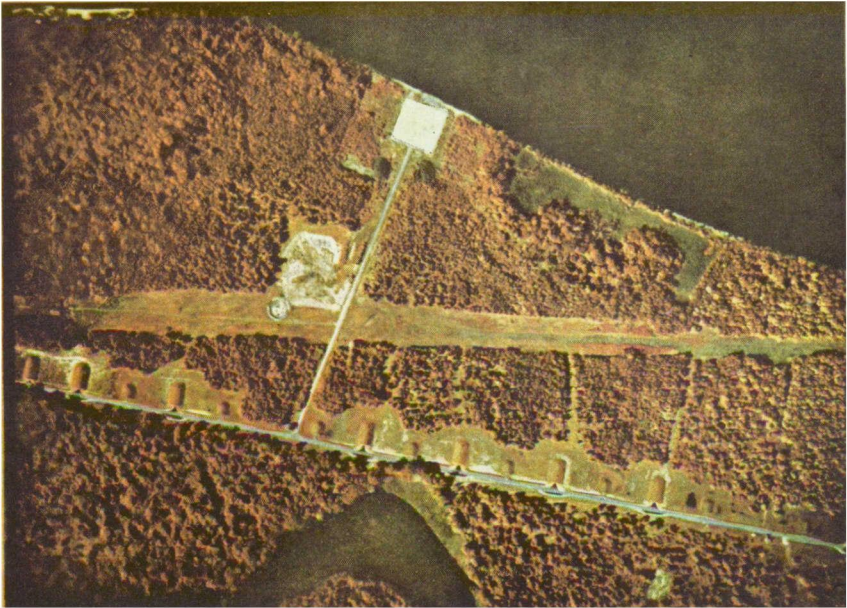

4 Camouflage detection film

Figure 5—Continued.

Section III. PREVENTING RECOGNITION

10. General

Recognition is the determination through appearance or behavior or movement of the hostile or friendly nature of objects or persons. One objective of camouflage concealment is to prevent recognition. In deceiving, the objective is to induce false recognition. This implies that camouflage is not always designed to be a “cloak of invisibility”; sometimes camouflage is designed to allow direction and often nature and circumstances do not permit the denial of detection, but recognition can be denied. For example, the use of improperly garnished drape nets over decoy equipment. Recognition through appearance is the result of conclusions drawn by the observer from the position, shape, shadow, texture, or color of the objects or persons. Recognition through behavior or movement includes deductions made from the actual movements themselves or from the record left by tracks of persons or vehicles or by other violations of camouflage discipline.

11. Factors of Recognition

Regardless of the type of observation, there are certain factors that help to identify an object. These factors are called factors of recognition. These are the telltale elements that determine how

quickly the object will be seen or how long it will remain unobserved. The 8 factors of recognition are position, shape, shadow, texture, color, tone, movement, and shine. These factors must be considered in camouflage to insure that 1 or more does not reveal the location.

a. Position. Position is the relation of an object or person to its background. When choosing a position for concealment, a background should be chosen that will virtually absorb personnel or an object or installation. 1, figure 6 illustrates improper position; 2, figure 6 illustrates an excellent position.

b. Shape. Shape is the outward or visible form of an object or person as distinguished from its surface characteristics and color. Shape refers to outline or form (fig. 7). Color or texture is not considered. At a distance the form or outline of objects can be recognized before the observer can make out details in their appearance. For this reason camouflage has much to do with concealing the shape of an object or person. A vertical photograph could show several different objects with similar shapes. For instance, a rectangular shape could be a building, a pool, a truck, or a parking lot. To positively determine the true identity, other factors are needed in addition to shape; one such factor is shadow.

c. Shadow. Shadow may be more revealing than the object itself, especially when seen from the air (fig. 8). Objects such as factory chimneys, utility poles, vehicles, and tents have distinctive shadows. Conversely, shadows sometimes may assist in concealment. Objects in the shadow of another object are more likely to be overlooked. It is more important to break up (make irregular), disrupt, or obliterate the shadow of an object by adding natural or artificial materials or both in the shadow area, than to conceal totally the object itself.

d. Texture. Texture is a term used to describe the relative characteristics of a surface, whether that surface is a part of an object or an area of terrain. Texture affects the tone and apparent coloration of things because of its absorption and scattering of light. Highly textured surfaces tend to appear dark (2, fig. 9) and remain constant in tone regardless of the direction of view and lighting, whereas relatively smooth surfaces (1, fig. 9) change from dark to light with a change in direction of viewing or lighting. The application of texture to an object often has the added quality of disrupting its shape and the shape of its shadow making it more difficult to detect and identify as something foreign to the surroundings in which it exists. As an example a surface having the same color but with heavy "nap" or texture is tall grass. Each separate blade is capable of casting a shadow upon itself and its surroundings. The light reflectance properties have been cut to a minimum. It will look and photograph dark gray. Looking straight down, the aerial observer sees all of the shadows whereas the man on the ground may not. The



1

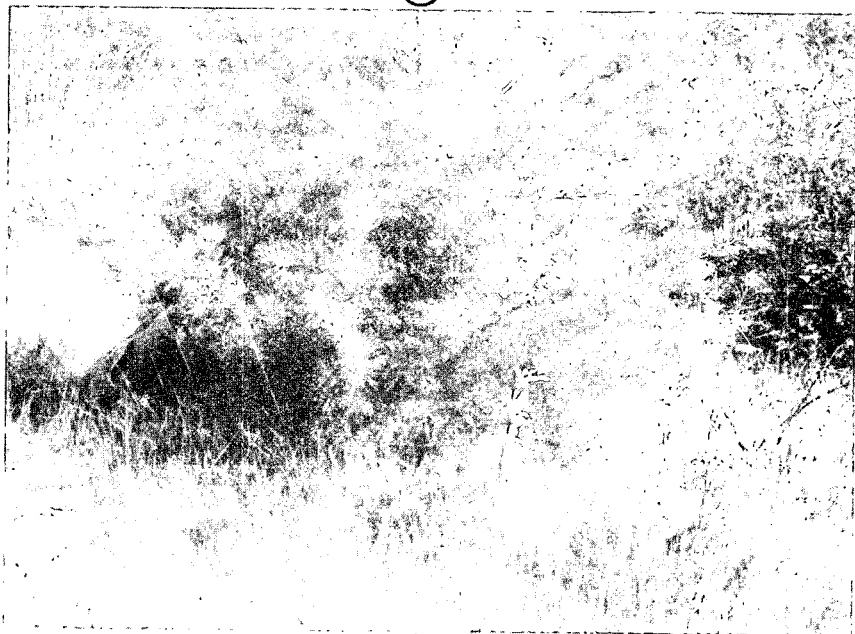

2

1 Improper position

2 Excellent position

Figure 6. Position.



Figure 7. Shape.



Figure 8. Shadow.



- 1 Shiny helmet before texturing
- 2 Helmet after texturing

Figure 9. Texture.

textured surface may look light at ground level but to the aerial observer the same surface produces an effect of relative darkness. The material used to conceal an individual or an object must approximate the texture of the terrain in order to blend in with the terrain. Personnel walking or vehicles moving across the terrain will change the texture by mashing down the growth. Therefore, this will show up clearly from the air as vehicle tracks or foot paths.

e. Color.

- (1) *Contrast.* Color is an aid to an observer when there is contrast between the color of an object and its background. The greater the contrast in color, the more visible the object appears (fig. 10).



Figure 10. Color contrast; lack of color contrast increases camouflage quality.

- (2) *Color characteristics and camouflage.* Color differences or differences in hue, such as red and green-yellow, become increasingly difficult to distinguish (or tend to merge) as the viewing range is increased. This is because of atmospheric effects. Colors in nature, except for certain floral and tropical animal life, are not brilliant. The impression of vividness of nature's colors results from the large areas of like colors involved and the contrast of these areas with each other. The principal contrast is in their dark and light qualities. However, the dark and light color contrast does

not fade out quickly and is distinguishable at greater distances. Therefore, as a first general principle, the camouflage should match the darker and light qualities of the background and be increasingly concerned with the colors involved as the viewing range is decreased or the size of the object or installation becomes larger. A second general rule to follow is to avoid contrasts of hues and when treating mobile objects in foliated terrains, light toned colors are to be avoided as they tend to attract.

- (3) *Tone.* Tone is the effect achieved by the mixing of light, shade, and color. In a black and white photograph, the shades of gray in which an object appears is known as tone. By adding texturing material to a smooth or shiny surface, the surface can be made to produce a darker tone in a photograph because the textured surface now absorbs more light rays. Objects become identifiable as such because of contrasts between them and their background. Camouflage blending is the process of eliminating or reducing these contrasts. The principal contrast is that of tone, i. e., the dark and light relationship existing between an object and its background. The two principal means available for reducing this contrast or difference in tone are the application of matching coloration and the use of texturing. As an example of coloration effects, a light-colored aircraft on a light-colored runway is most easily located by its shadow (1, fig. 11), while the same aircraft on a darker runway is easily picked out through its own contrast with its background (2, fig. 11). If all color contrasts are reduced, a dark-colored aircraft on a dark-colored runway is relatively inconspicuous or practically disappears from view (3, fig. 11). Installations subject only to high aerial observation can best be concealed by toning down contrasts in shade and color rather than by attempting complicated disruptive patterning. Poorly chosen disruptive patterns tend to make the object more conspicuous instead of concealing it.

f. Movement. Movement is the strongest factor in attracting attention. The eye is very quick to notice any movement in an otherwise still scene. The aerial camera can record the fact that something has moved when two photographs of the same area are taken at different times (1 and 2, fig. 12). If an object has moved, the changed position is apparent when the two photographs are compared.

g. Shine. Shine (fig. 13) is a particularly revealing signal to an observer. Whenever light strikes a smooth surface such as windshields, headlights, mess gear, or a person's face, light may be reflected directly into the observer's eye or the camera's lens with striking emphasis.

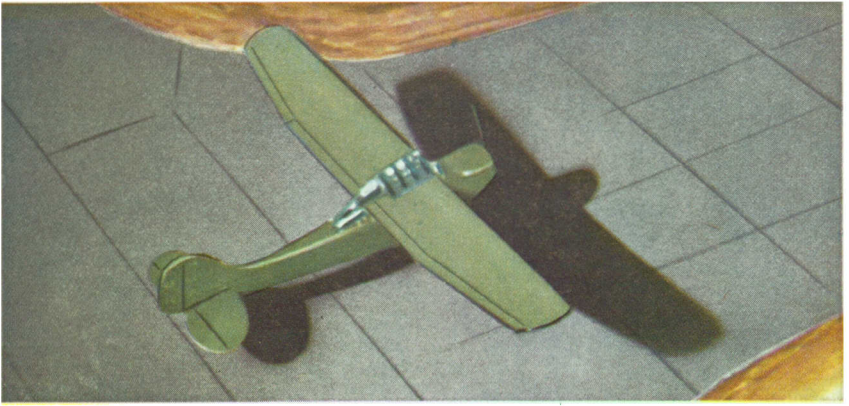

①

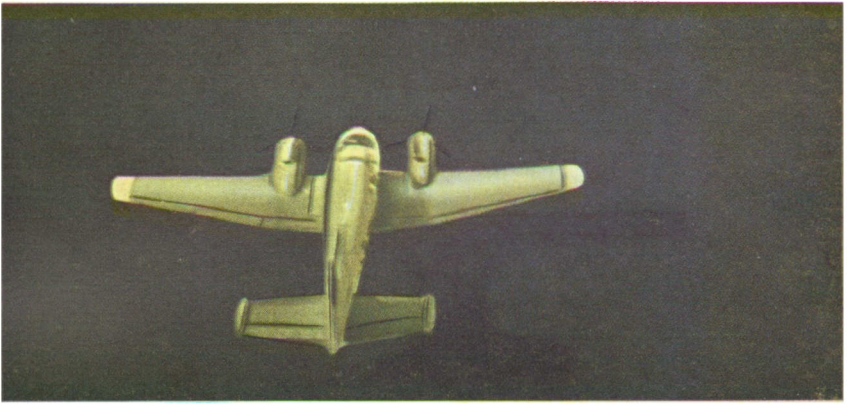

②

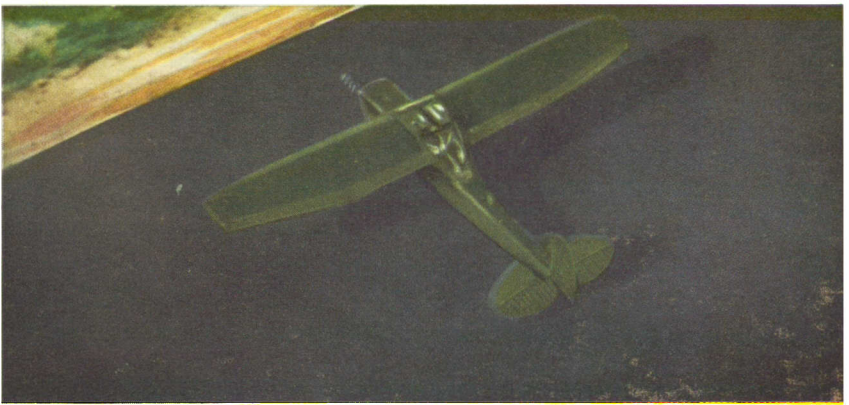

③

- 1 Light colored aircraft on light colored runway
- 2 Light colored aircraft on dark colored runway
- 3 Dark colored aircraft on dark colored runway

Figure 11. Tone contrast between aircraft and background.



1: Area before movement

2: Area after movement

Figure 12. Movement.



Figure 13. Shine.

CHAPTER 3

PRINCIPLES AND METHODS OF CAMOUFLAGE

12. Factors in Concealment

No matter how applied, camouflage can be successful only by observing three fundamental requirements. These are the basic principles of camouflage: choice of position, camouflage discipline, and camouflage construction.

a. Choice of Position. When choosing a position to gain concealment a background is chosen that will visually absorb the elements of the position. The appearance of the background must be changed as little as possible by the presence of individuals, weapons, or equipment, or both. The position selected must not hinder the accomplishment of the mission. With these requirements foremost in mind, a "natural" position is located; that is, a position that can be used almost as it is, such as a natural cover or a defilade. The terrain should accommodate the layout of the installation when properly dispersed. Isolated landmarks such as individual trees, haystacks, or a house should be avoided because they attract attention to themselves. At times, by making use of background, complete concealment against visual and photographic detection may be gained with no construction. In terrain where natural cover is plentiful, this is a simple task. By taking advantage of terrain irregularities, even though natural cover is scarce, complete concealment may be gained without added camouflage construction (fig. 14).

b. Camouflage Discipline.

- (1) *Daytime.* Camouflage discipline is the avoidance of activity that changes the appearance of an area or reveals military objects to the enemy. A well camouflaged position is only secure as long as it is kept well maintained. Concealment is worthless if obvious tracks point like directional arrows to the heart of the location or if signs of occupancy are permitted to appear in the vicinity (fig. 15). Tracks, spoil, and debris are the most common signs of military activity that indicate concealed objects. Therefore, existing tracks, paths, roads, or natural lines in the terrain are to be used. Exposed routes are not to end at a position, but are extended



Figure 14. Position selected to take advantage of terrain irregularities.

to another logical termination. If practical, exposed tracks are camouflaged by brushing them out, by covering them with material, or where time permits by planting local vegetation. Spoil and debris are covered or placed to blend with the surrounding terrain. Smoke from kitchen fires must be controlled and dispersed.

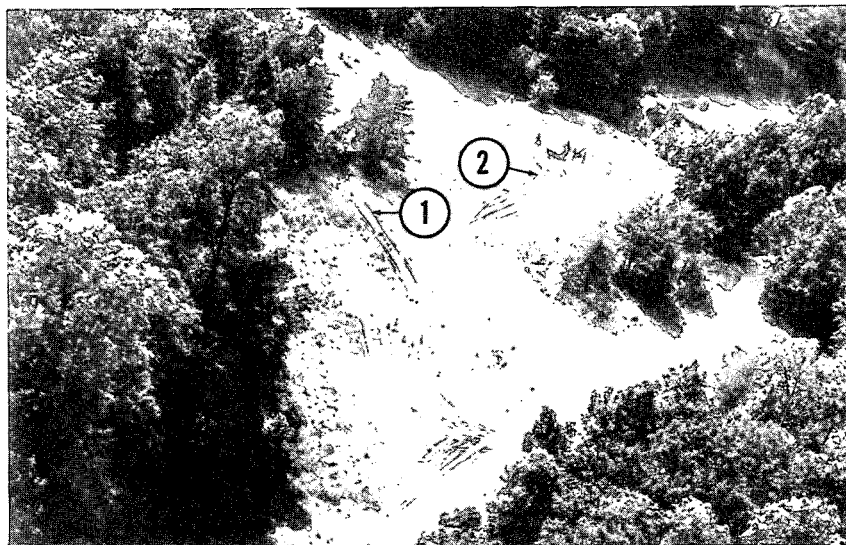

1 Tracks of tank parked among trees 2 Tracks of supply vehicles to gun position

Figure 15. Obvious tracks revealing position.

(2) *Night.* Concealment at night is less necessary than in the daytime. Therefore the enemy can use the cover of darkness to his advantage. He can do this much easier than he can in daylight if he is given clues to guide him. Camouflage discipline thus becomes doubly important at night to keep from attracting attention. Aerial photos taken at night by light furnished by flares dropped from planes can pick up breaches of camouflage discipline which are more likely to occur at night than during the day. Light discipline is very important at night. Sound discipline is always important. Noises seem magnified at night; clanking gears or snoring may prove fatal. Calling to one another, talking, even whispering, should be kept to a minimum. By far the most important phase of night discipline is *light discipline*. Necessary work lights are to be shielded by using them inside an inclosure, such as a lightproof tent or bunker. Even on the darkest nights eyes grow accustomed to the lack of light in approximately 30 minutes. Every time a match is lit or a flashlight is used the eyes must go through the complete process of getting adjusted to the darkness again. Smoking is to be prohibited at night in areas of close proximity to the enemy because the light is impossible to conceal. A cigarette light aggravates the situation by creating a reflection which completely illuminates the face (fig. 16).

(3) *Sound.* Sound can be lessened by precautionary measures. Loud orders, talking, calling, and sneezing must be avoided. Walking on hard surfaces should be avoided and full use should be made of soft ground for digging. Hand signals or signs should be used when possible. Individual equipment should be padded and fastened in such a manner as to prevent banging noises. Loading and unloading of vehicles must be accomplished in silence; every piece must be carefully lifted and gently set down; and straw, wood shavings, or other muffling agents should be used for packaging. It may become necessary to disconnect vehicle horns and shut off engines. The noise of engines and tracked vehicles cannot be diminished while in movement. However, it can be drowned out by the noise of artillery fire and planes and other loud noises created by sound simulators. In order to prevent the enemy from locating gun positions, decoy positions equipped with flash and sound simulators are to be used. Troops used as decoys and equipped to simulate the sound of firing or for the use of simulator devices make sound ranging more difficult. If this system cannot be em-

ployed, other more elaborate battlefield noise and light deceptive devices should be employed. For additional information on noise and flash simulation, see FM 5-23.

c. Camouflage Construction. Camouflage construction is used for a camouflaged position that requires additional concealment. Camouflage construction is the employment of artificial and natural materials to help blend personnel and equipment with the surrounding terrain. Artificial materials are manmade and include such items as paint, wire, burlap, chicken wire, fiberglass, garnished nets of various types and sizes, and osnaburg, a cotton cloth more closely



Figure 16. Light reflected on face revealing position at night.

woven than burlap. For additional information on artificial materials see FM 5-22. If proper choice of natural materials is made they will resemble the surrounding terrain pattern in form and color. One disadvantage is that after cutting, vegetation quickly fades, wilts, and must be constantly replaced.

d. Blending Artificial Materials. If artificial materials are used they must be arranged to blend with the surrounding terrain (fig. 17) and must be capable of withstanding local weather conditions. Seasonal changes may require gradual alteration in the color or kind of



Figure 17. Artificial materials blending with surroundings.

material used. Construction must be hidden and work parties must observe camouflage discipline.

13. Camouflage Methods

There are three fundamental ways of concealing installations and activity: by hiding, blending, and deceiving.

a. Hiding. Hiding is the complete concealment of an object. The art of hiding (fig. 18) is to be mastered by every soldier.

b. Blending. Blending is the arrangement of camouflage materials on, over, and around an object so that it appears to be part of the background. The aim is to prevent detection of the object by a change in the natural appearance of the position. Because the works of man are usually geometric in form, they present easily recognized outline and rectangular shapes and shadows which are very unlike the average terrain in features. Blending (fig. 19) distinctive man-made objects into the normal terrain pattern is necessary in order to restore and simulate its normal and natural appearance.

c. Deceiving. Deceiving simulates an object or situation or disguises it so that it appears to be something else. Deception misleads the enemy as to identity, strength, intentions, or activity; deception divides his attack and draws his fire away from essential targets. Well planned and cleverly executed decoys are among the most effective ways to deceive the enemy as to our strength, intention, and location of positions. Pneumatic devices, called targets, have been manufac-

tured for use in the field and look like various vehicles and artillery pieces (fig. 20). If these decoy devices are not available, units can make expedient ones from materials at hand. For more information on deception see FM 5-23.



Figure 18. An example of hiding.



Figure 19. Blending.



Figure 20. Deceiving by use of decoys.

CHAPTER 4

GEOGRAPHIC FACTORS

Section I. TEMPERATE ZONE

14. General

When not otherwise specified, temperate zone terrain is to be assumed in this manual. Desert, snow, and ice areas are mostly barren and require much construction effort. Jungle and semitropical areas are mostly wooded and heavily vegetated and afford excellent concealment with very little construction effort.

15. Seasonal Changes

The cycles of the seasons bring marked changes in vegetation, coloring, and terrain pattern requiring corresponding changes in camouflage. Concealment which is provided in wooded areas during the summer is lost when leaves fall in the autumn. This will create a need for additional camouflage construction. Where rainfall is heavy, provisions must be made to anchor flattop net posts. When ground is frozen, counterbalances are used instead of pickets, or anchor stakes. Camouflage construction must provide strength to support heavy loads of snow in winter.

Section II. DESERT

16. Concealment Factors

a. Lack of natural concealment, high visibility, and bright tone (smooth texture), all emphasize the need for careful selection of a position. Deep shadows in the desert (fig. 21), dispersion, strict observance of camouflage discipline, and the skillful use of deception and camouflage materials aid in concealment of a unit in a desert area.

b. Desert areas (fig. 22) are not always flat, single-toned areas. They are sometimes characterized by strong shadows with heavy broken terrain lines and sometimes by a mottled pattern (fig. 23). Each type of desert terrain presents its own problems. Because shadows of equipment located in the desert are inky black and are in strong contrast to their surroundings, they are extremely conspicuous. To minimize effect of these shadows, it is desirable to dig in equipment whenever possible. Some concealment is afforded by the shadows of deep gullies and scrub growth.

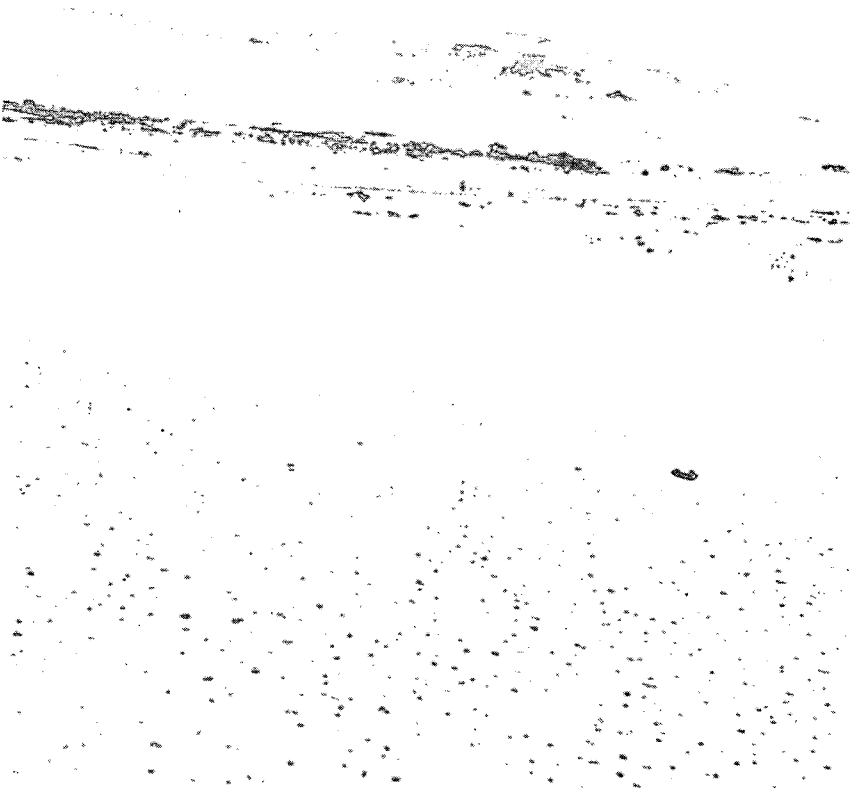

Figure 21. Desert area presenting problems in concealment.

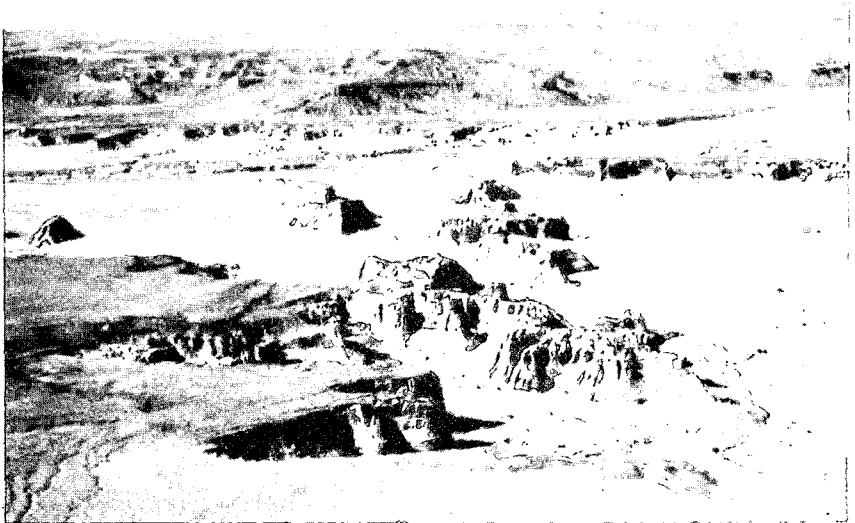

Figure 22. Desert areas offering aid in concealment.

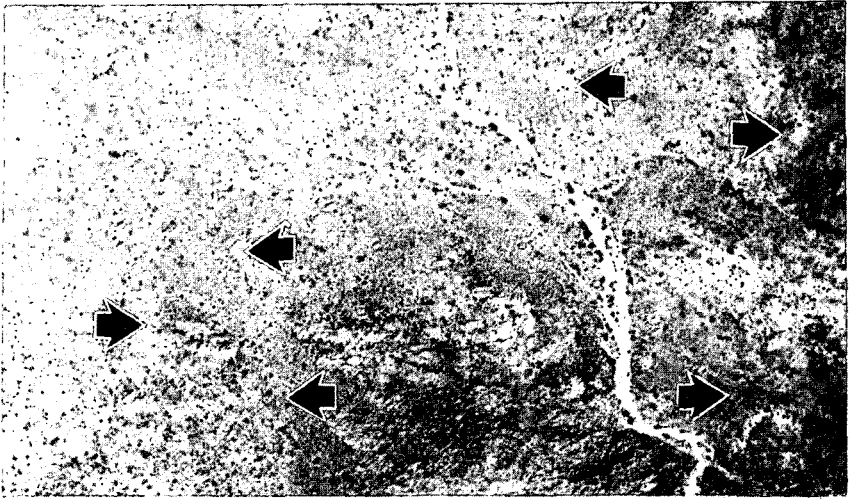
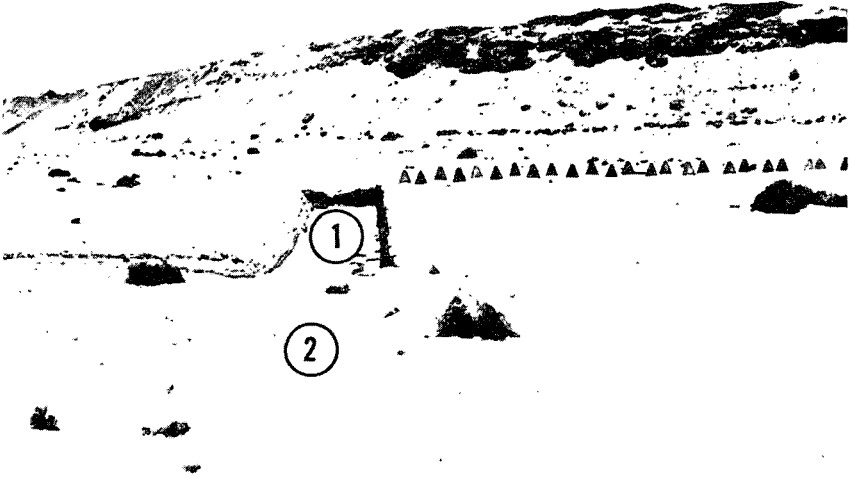

Figure 23. Vehicles concealed in mottled pattern in desert.

c. Many objects which cannot be concealed from aerial observation can be effectively screened from ground view. Even though these objects are observed from the air, lack of reference points in the terrain will make them difficult to locate on a map. For example, an antitank ditch covered with wire netting, garnished with natural material to match surrounding terrain, is visible from the air because of its deep shadow, but attacking tanks, because of their limited range of observation, often cannot distinguish the ditch from its surroundings (fig. 24). This is true also of well-camouflaged trenches.



- 1 Uncamouflaged portion of antitank ditch
- 2 Covered and camouflaged portion of antitank ditch

Figure 24. Camouflaged antitank ditch.

Covered and irregularly positioned, they become much more difficult to distinguish from the ground.

d. Siting a unit is the most important factor of concealment in the desert (fig. 25). Full advantage must be taken of any terrain pattern encountered. Slopes into valley floors are usually cut by dry washes and offer limited defilade and natural concealment for vehicles and artillery. Valley floors in most deserts have little or no natural concealment. Occupation of dry washes and arroyos (deep gullies) exposes the unit to the hazards of flash floods. High areas must be used during rainy seasons.



Figure 25. Siting in the desert.

17. Artificial Materials

Suitably garnished drape nets are useful in concealing equipment in the desert. The drape nets must be heavily garnished and are most effective when tied in with the natural terrain features and used over dug-in installations (fig. 26). The slope of screens to avoid shadow-casting angles must be low and gentle for best protection. Paint can be used to reduce tone contrast. Colors in desert areas must generally be light, and simulated shadows must be very dark.



Figure 26. Drape net concealing equipment in the desert.

Section III. JUNGLE

18. General

The abundance of natural concealment, both overhead and at ground level, limits military observation to the ground view and, normally, at very close, almost hand-to-hand range. For these reasons camouflage in jungle operations is a more personal, individual effort than in temperate or desert climates. Wide use is made of natural concealment by hiding, by blending with backgrounds and shadow patterns, and by screening individuals and emplacements with natural materials (fig. 27). There are many opportunities for small-scale deceptive practices such as simulated small arms fire and mortar fire. Overhead foliage must be preserved, particularly in clearing fields of fire for weapons. Slashings of jungle vegetation draw immediate attention from enemy aircraft.

19. Combat Concealment

Jungle fighting requires the use of great stealth and taking advantage of the concealment offered by the jungle growth. Full advantage of jungle growth must be taken to mask all operations and confuse, trap, and destroy the enemy.

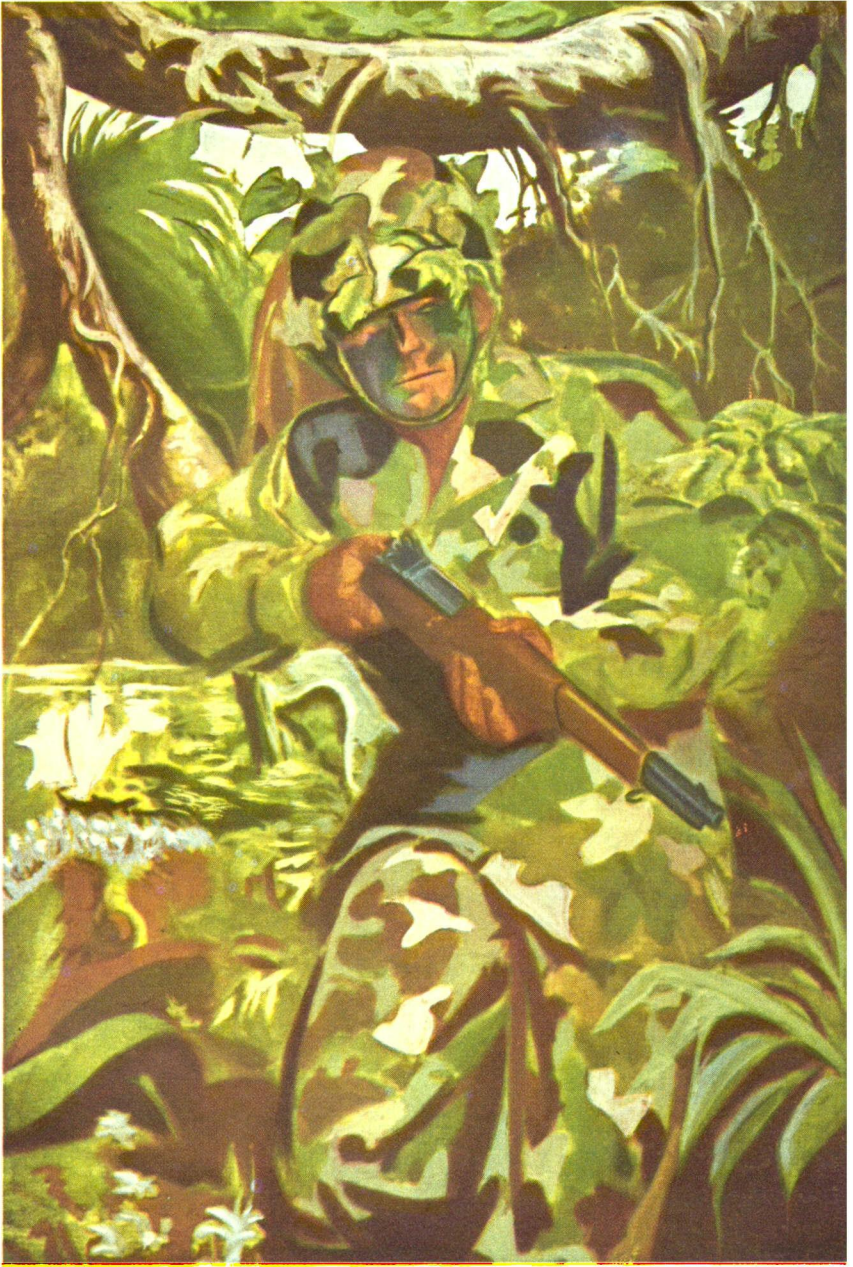

Figure 27. Concealment in the jungle.

Section IV. SNOW AND ICE

20. General

From the air, snow-covered terrain (fig. 28) is an irregular pattern of white, spotted with dark tones produced by objects projecting above the snow, their shadows, and irregularities in the snow-covered surface such as valleys, hummocks, ruts, and tracks. It is necessary, therefore, to make sure that dark objects have dark backgrounds for concealment, to control the making of tracks in the snow, and to maintain the snow cover on camouflaged objects. For camouflage purposes, the snow-

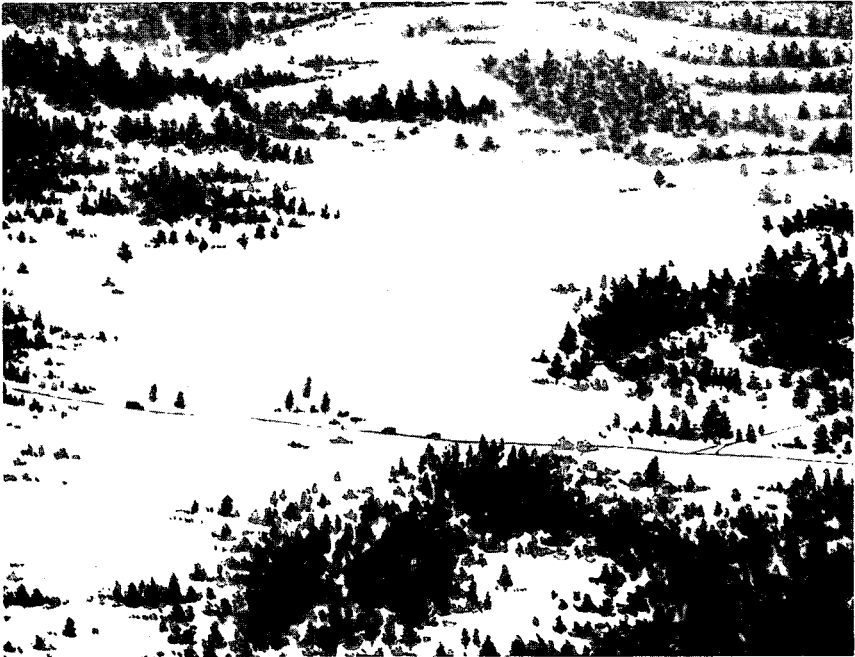

Figure 28. Aerial view of snow-covered terrain.

covered ground can be divided into the main types of terrain listed below.

a. Mountain Areas Above Timberline and Arctic Areas. Common characteristics of these areas are an almost complete snow cover with a minimum of opportunities for concealment. Only a few dark objects protrude above the snow. The exceptions to this are on very rugged mountain peaks.

b. Mountain Areas Below the Timberline and Subarctic Areas. Common characteristics of these areas are forests, rivers, lakes, and manmade features such as trails and buildings. The appearance of the areas is irregular in pattern and variable in tone and texture.

c. *Areas Between the Subarctic Zone and the Southern Boundary of the Temperate Area.* These have the same characteristics as those given for *b* above.

21. Blending With Background

No practical artificial material has yet been developed which will reproduce the texture of snow sufficiently well to be a protection against recognition by aerial observers. Concealment from direct ground observation is relatively successful with the use of white snowsuits (fig. 29), white paint, and whitewash; these measures offer some protection against aerial detection.

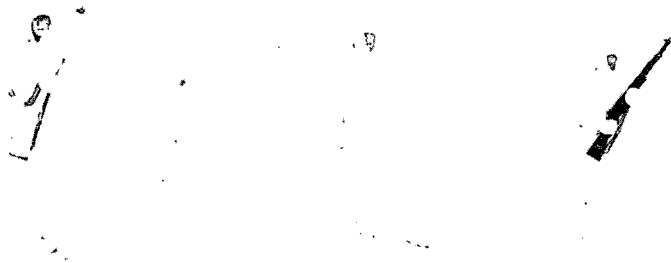

Figure 29. Snowsuits and comparison between rifles, whitewashed and uncamouflaged.

22. Use of Decoys

Snow-covered terrain offers many possibilities for deceiving the enemy. If ski tracks are used for decoy purposes, the tracks should be renewed occasionally to keep them looking fresh. The methods are covered in FM 31-70.

23. Concealment Practices

Camouflage construction must be strong enough to support the weight of heavy snow loads (fig. 30), and the buffeting of high winds. Tracks must be controlled because in snow they show up as lines of dark shadows and it is almost impossible to obliterate them completely by brushing or other means. Tracks should always be continued on past installations to logical destinations. Cotton twine nets garnished in white can be made up in the field from issue materials. When con-

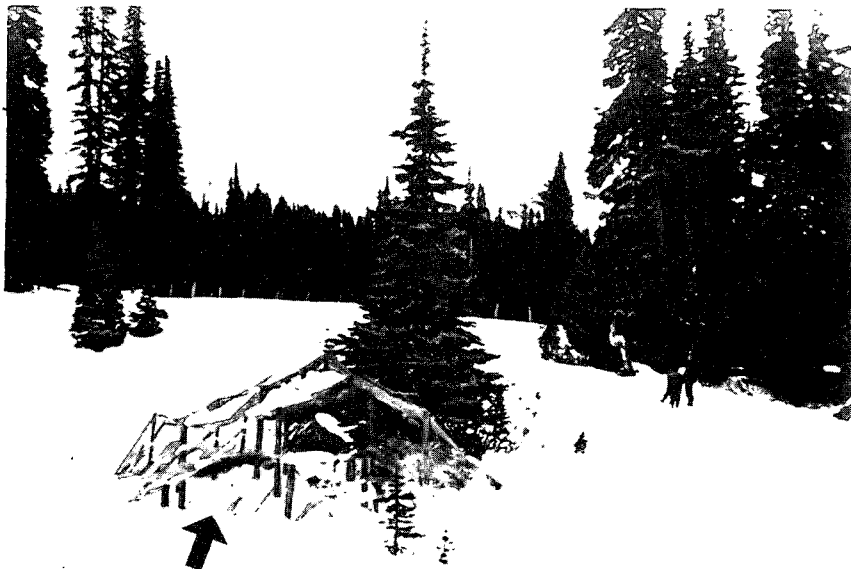

STURDY POST AND WIRE MESH
CONSTRUCTION

Figure 30. Camouflage construction in snow regions.

ditions warrant, dark-colored garnishing materials can be interspersed with the white fabric. The fine-meshed wire screening shown in figures 30 and 31 or feather-garnished white chicken wire are the most prac-



Figure 31. Nets used to catch snowfall.

tical means for concealing supplies in a snow-covered area. The following precautions are to be taken in snow areas:

a. Care must be taken to muffle the sounds of moving men and equipment because sound carries farther in snow country.

b. In arctic regions the length of the hours of darkness assists in concealing movement, but during extended periods of daylight concealing movement is extremely difficult.

c. Concealed movements can often be made successfully in arctic regions during the frequent periods of cloudiness which hamper aerial observation.

d. When tanks or other tracked vehicles turn quickly small mounds of snow are piled up and reveal the nature of the vehicle. Such snow mounds should be brushed out. If tanks turn slowly in a gradual arc these snow mounds are not formed.

e. A road grader may be used to help obliterate tank tracks on ice or a hard crust road surface.

f. Movement of troops and supplies, in the arctic during the summer months, creates quite a problem as far as concealment is concerned, because of long periods of daylight. However, during twilight hours movement of troops and supplies can be conducted successfully and with considerably less chance of visual detection by enemy observers because the eye automatically adjusts to the light of the bright sky, reducing the contrast in the darker terrain. Maximum advantage should be taken of the twilight hours for such movements.

g. Because shine is often the only revealing feature of an object, it is to be eliminated.

h. Full use should be made of terrain irregularities in the parking of vehicles.

i. If white covers are not available, dark ones can be used if they are covered with a layer of snow.

j. Thawing conditions are advantageous to camouflage since they reveal dark patches and form a disruptive pattern.

k. The degree of whiteness of artificial materials used for camouflage in snow terrain must be carefully chosen. A tint of yellow or red will betray the camouflage. White with a bluish tinge is preferable. Fluorescent bleaches common to laundry detergents may be used to increase the apparent whiteness of fabrics.

CHAPTER 5

USE OF NATURAL AND ARTIFICIAL MATERIALS

Section I. NATURAL MATERIALS AND THEIR USES

24. General

Any type of material indigenous to the locality of the site to be camouflaged may be classified as natural material. Natural materials consist of foliage, grasses, debris, and earths. These materials match local colors and textures and when properly used are an aid against both direct and indirect observation. The use of natural materials provides the best type of concealment, is more economical, and reduces transportation requirements for artificial materials to and within the area of operations. The chief disadvantage of natural foliage materials is that they cannot be prepared ahead of time, are not always available in usable types and quantities, wilt after cutting, and must be replaced periodically. Foliage of coniferous trees (evergreens) retains its camouflage qualities for considerable periods, but foliage that sheds leaves wilts in a day or less depending on the climate and type of vegetation. The various types of materials used for camouflage purposes are described below.

25. Natural Materials

a. Live Vegetation. The principal advantage in the use of live vegetation is its ability to reflect infrared waves and to blend in with surrounding terrain. In some instances relatively large trees are transplanted to furnish concealment; however, the planting or transplanting of plant material requires time, skilled labor, and an adequate water supply, especially in the early stages. Live vegetation is permanent and, when firmly rooted, requires a minimum of maintenance. Planted vegetation often takes considerable time to grow to a size providing maximum concealment. For this reason its value is limited in field use. Small trees and bushes can be potted successfully with no special skill or equipment if adequate water is available. In barren areas, scrub growth is an excellent supplement to artificial garnishing on nets.

b. Grasses.

- (1) *Controlled mowing.* The controlled mowing of grasses is a technique sometimes included in camouflage plans of airfields and rear area installations. Controlled mowing means mow-

ing one section or area all at the same height and in the same direction, with adjacent areas of different heights and directions. This result produces effective changes in the color and texture of the ground areas and makes them appear to be fields with different crops (fig. 32).

- (2) *Toning*. Grass may be toned to simulate fields by spraying with chemicals such as iron sulphate, sodium arsenite, or ammonium thiocyanate. The process must be carefully controlled. The vegetation will be discolored, but the damage will be slight and temporary. After a period of a few

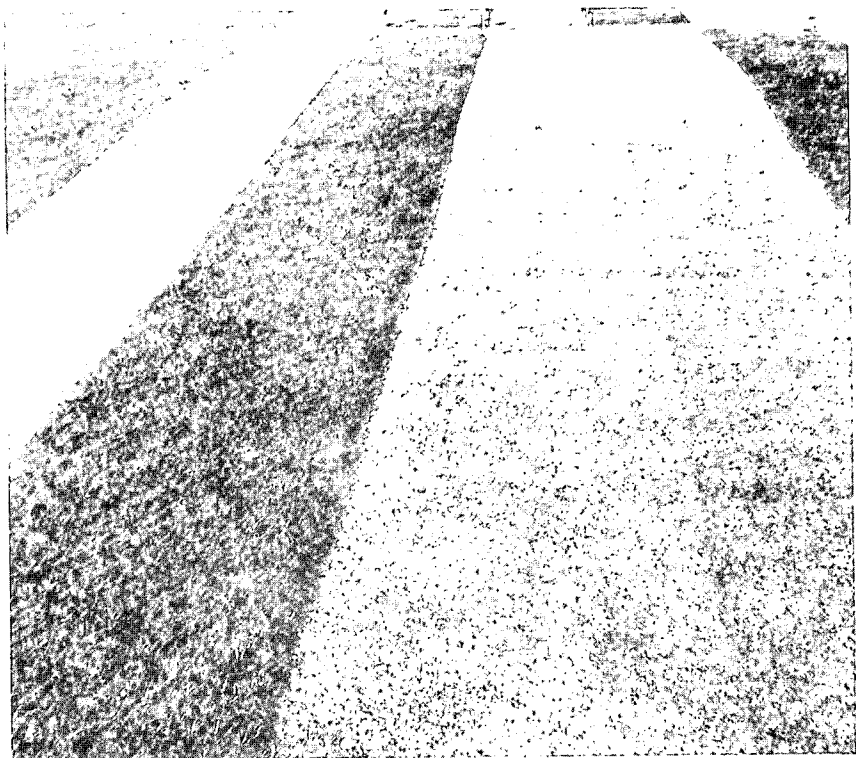

Figure 32. Ground patterning by controlled mowing.

days to a few weeks, depending on the rates of application employed, the grass resumes normal growth. In the case of ammonium thiocyanate, the grass turns a rich deep green following the burn, because of the nitrogen supplied by the spray. Asphalt emulsions and tannin dye also are suitable for toning. Waste oil may be used, but it prevents growth of grass for several months after application. For more information on toning, see FM 5-22.

c. Cut Vegetation.

- (1) When cut vegetation is used as garnishing or screening, it must be replaced with fresh-cut materials or painted before it has wilted sufficiently to change the color or the texture. If vegetation is not maintained it is ineffective. Thorn bushes, cacti, and other varieties of desert growth retain growing characteristics for long periods after being cut. Evergreens are also long lasting.
- (2) The arrangement of cut foliage is important. The upper sides of leaves are dark and waxy, the under sides are



Figure 33. Placing cut foliage in a natural growing position.

lighter. In camouflage, therefore, cut foliage must be placed as it appears in its natural growing state (fig. 33), top side of leaves up and tips of branches toward the outside of the installation. Cut foliage must be matched to existing foliage. For example, foliage from trees that shed leaves must not be used in an area where only evergreens are growing. Foliage with leaves that feel leathery and tough should be chosen. Branches grow in irregular bunches and, when used for camouflage, must be placed in the same way. When branches are placed to break up the regular, straight lines of an object, only enough branches to accomplish this pur-

pose need be used; it is not necessary to cover the object completely.

d. Use of Debris in Concealment. Debris furnishes valuable means of concealment. Frequently it may be used just as it is found. Positions concealed by debris require little maintenance. Debris also makes excellent decoys. Salvage aircraft, for instance, may be placed in partly concealed positions and, with the addition of simulated activity nearby, make effective decoys. Rusty tin cans cut into strips and combined with cloth and shaped to resemble plants can be used to garnish wire nets.

e. Earths. Earth, sand, and gravel are used to change or add color, provide coarse texture, simulate cleared spots or blast marks, and create shapes and shadows.

- (1) *Earth.* Earth, in mud form, provides good material for tonedown of bright surfaces. With mud, the combat soldier can quickly tone down his shoes, web equipment, and vehicle.
- (2) *Sand.* Sand adhering to paint or oil provides means for toning down vehicles in the desert. In the desert, dispersed supply points of low and irregular outline covered by tarpaulins can be hidden effectively by covering them with sand.
- (3) *Gravel.* Gravel is used to provide texture on roads, roofs, and other flat surfaces (except runways).

Section II. ARTIFICIAL CAMOUFLAGE MATERIALS AND THEIR USE

26. General

Artificial camouflage materials may be defined as *issued or captured* materials which have been manufactured for the express purpose of camouflage. These artificial materials are not used until every effort has been exhausted to conceal the object within the natural terrain. Artificial materials are only an aid in helping to conceal the object and they are used in conjunction with the basic principles and methods of camouflage.

27. Artificial Materials

a. Coloring Materials. Coloring materials include paints, stains, and dyes. For further information see FM 5-22.

b. Wire. A particular advantage of both 10-gage and 16-gage issue-type wire is that it will not glare or shine if placed in the sun. It is normally employed as follows:

- (1) Number 10 wire is used as a supporting wire for flattops, as guys, and as strands for wire cable.

- (2) Number 16 wire is used to attach the perimeter wire on flat-tops, to support natural material in an upright position, to sew burlap, and for wired paths. It can also be twisted into cables.

c. Garnishing and Screen Material. Artificial garnishing has the advantage of being relatively permanent, available through supply channels, and prefabricated. Its color will not always match the surrounding terrain. This is especially true when pregarnished nets are used. In such cases, garnishing materials to match the terrain must be substituted. Of these, burlap garnishing is the best since it is very loosely woven and therefore has a texture that is superior to the other materials discussed. Burlap garnishing material is available in all standard camouflage colors except white, and osnaburg material is available in all standard colors except black.

d. Supporting Materials. Nets and netting of the large-mesh type are used extensively for screening materials. Nets are of no value for concealment unless the openings are filled in and textured with garnishing materials. Large-mesh nets of twine and netting of wire are issued either garnished or ungarnished. The design of the nets makes them adaptable for use in nearly all types of terrain, but they are particularly useful in concealing weapons in barren or desert areas where natural aids to concealment are lacking. The two main classes of supporting materials are wire netting and cotton twine nets.

- (1) *Wire netting.* Wire netting (netting, camouflage wire, steel) is issued in 6-foot-wide rolls of various lengths and is available either ungarnished or garnished with steel wool, feathers, glass fiber, or fabric. It is rustproof and fire resistant and has less tendency to sag or deteriorate in use than do the cotton twine nets. Because it is bulky and stiff, wire netting is not intended for numerous erections and dismantlings in the manner that twine nets are employed by mobile units. In molded or shaped screens, however, it will hold a shape indefinitely and it is the best covering material for such use.
- (2) *Twine nets.* Large-mesh twine nets are used as individual camouflage drapes for equipment, as component parts of camouflage net sets (drape-type), or as covers for flattops in temporary installations. Twine nets shrink as they become wet and expand when drying out. Nets, when garnished as drape-type, are effective in concealing an object from direct and aerial observation. Nets, when garnished as flattops, are effective in concealing an object from aerial observation.

28. Garnishing Patterns

There are 2 types of garnishing patterns used in garnishing twine nets. The drape pattern (fig. 34) and the flattop pattern (fig. 35). To provide for blending into a variety of seasonal and geographic terrain characteristics, pregarnished nets are available in 2-color blends, all-seasonal and desert. The overall color blend of a net is achieved by indiscriminately mixing the garlands of the various col-

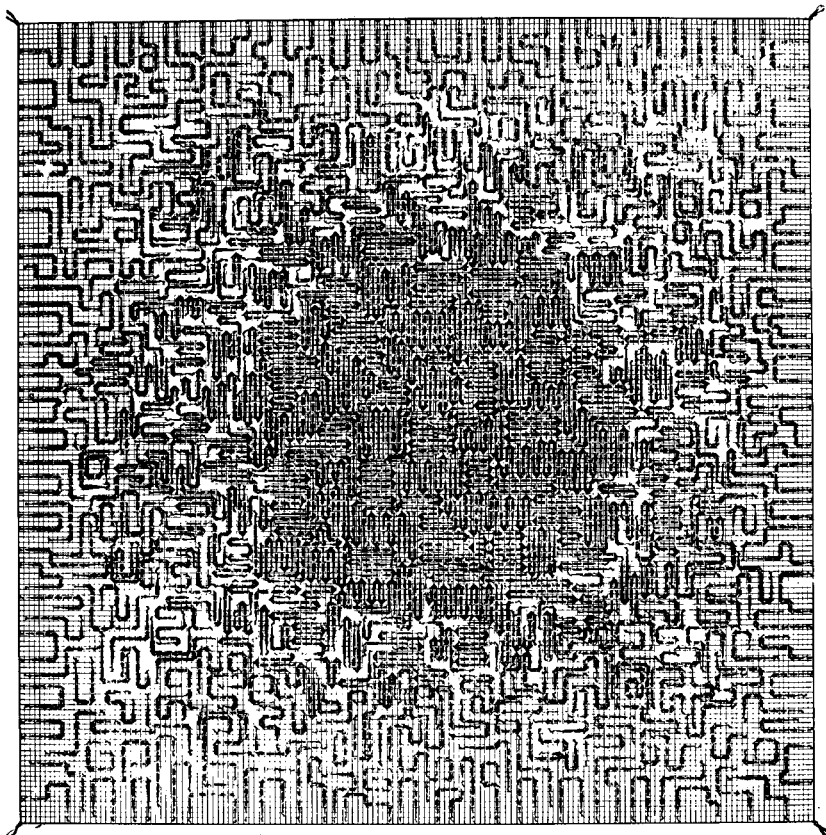

Figure 34. Drape pattern.

ors required for a particular blend and placing the garlands in the net at random as an overall mixture of colors. Long straight runs, large areas, or blocks of 1 color, or regularity of a color pattern in a net should be avoided. In broken and mottled terrain patch garnishing is to be used to match the terrain pattern and in densely wooded areas bow-tie garnishing is to be used.

29. Drape Nets

Drape nets (individual) are pregarnished twine nets, designed to provide concealment for vehicles, tanks, trailers, other similar equipment, and installations. Properly garnished and properly employed drape nets conceal from both air and ground level observation. The low silhouette and gradually sloped sides of drape nets eliminate sharp telltale shadows which are usually the most important factor in ground target identification from the air. These drape nets are available in two seasonal blends: all seasonal and desert.

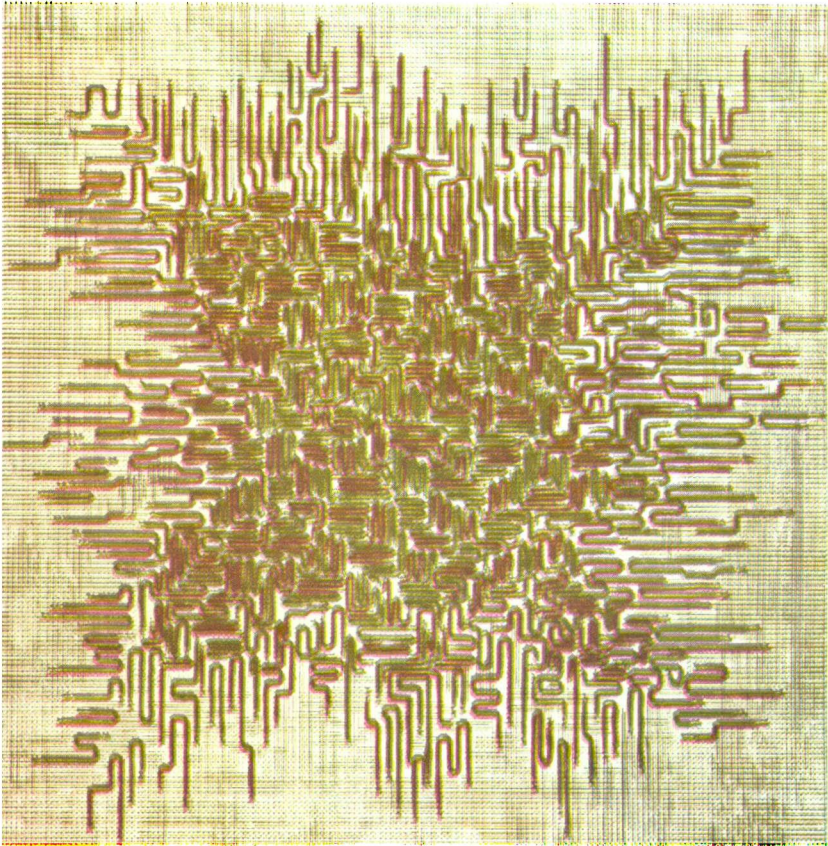

Figure 35. Flattop pattern.

30. Drape Net Sets

a. These pregarnished net sets consist of pregarnished nets, hardware, and necessary tools and equipment needed for erection. Each component net is so garnished that when assembled in the net set, a single overall garnishing pattern is obtained. These net sets can be quickly and easily erected. They are designed not only to conceal equipment and weapons but also entire emplacements from all angles

of observation. This is necessary because each weapon has a characteristically shaped emplacement which is easily detected and identified, especially from the air. Thus the critical factor in determining the size of the net or a net set to be used for a particular piece of equipment is the emplacement rather than the equipment itself.

b. The scarred area in the immediate vicinity of the emplacement must be covered for effective concealment. Freshly turned earth usually is brighter than the untouched surroundings and can be detected even through the garnishing of a net, especially when the nets are suspended close to the spoil. To make the fresh earth less conspicuous it may be covered or toned down by colored tarpaulins, sandbags, bushy vegetation, or other suitable materials.

c. In circular emplacements the areas outside the site beneath the drape net set can be used for foxholes or ammunition storage. Support poles are conveniently placed in these areas to provide head space and approaches to the pit. In rectangular emplacements, the side area outside the pit may also be used for these purposes.

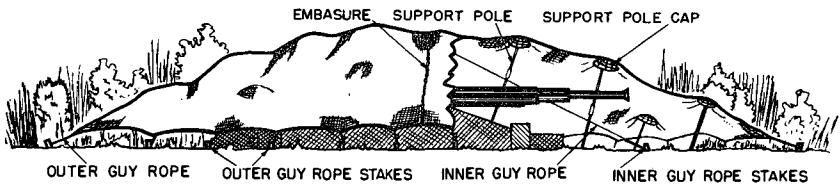

Figure 36. Cutaway of typical drape net set.

d. The straight lines presented by the overall net set are to be disrupted. This is accomplished by staggering support poles at various intervals and heights (fig. 36). Uniformity of appearance in net sets is not desired because this in itself might furnish the necessary information to enable the enemy observer to detect the type and kind of emplacement.

31. Composition of Drape Net Sets

Garnished nets are held rigidly in place by guyropes. Poles of 1-inch steel tubing, with wire caps (fig. 36) are used to support the nets over the weapons to be concealed. Each pole section is 4 feet 3 inches long. The poles are designed to be extended in segments of 4 feet by inserting 1 pole section into the pipe on the end of another pole section. The pole sections are held together by spring locks. To prevent damage to the nets and to avoid a jagged or telltale outline caused by the appearance of sharp points at intervals along the nets, lightweight wire caps, shaped like inverted cups, are placed on top of the poles. These caps have a diameter of 20 inches and are held in place on the poles by 3 wire prongs which are designed to

release themselves automatically when the pole falls to the ground in order to prevent damage to the caps. Each drape net set is equipped with quick-opening embrasures which bisect the length and in some cases the width of the set. These embrasures are located along the lines where the nets are joined and permit the nets to be partially opened or dropped so that they will not interfere with elevating the tube of the weapon and will not be damaged by muzzle blast or rocket blast.

32. Flattops

A flattop consists of a twine net (or chicken wire for more permanent installations) that is stretched parallel with the ground and

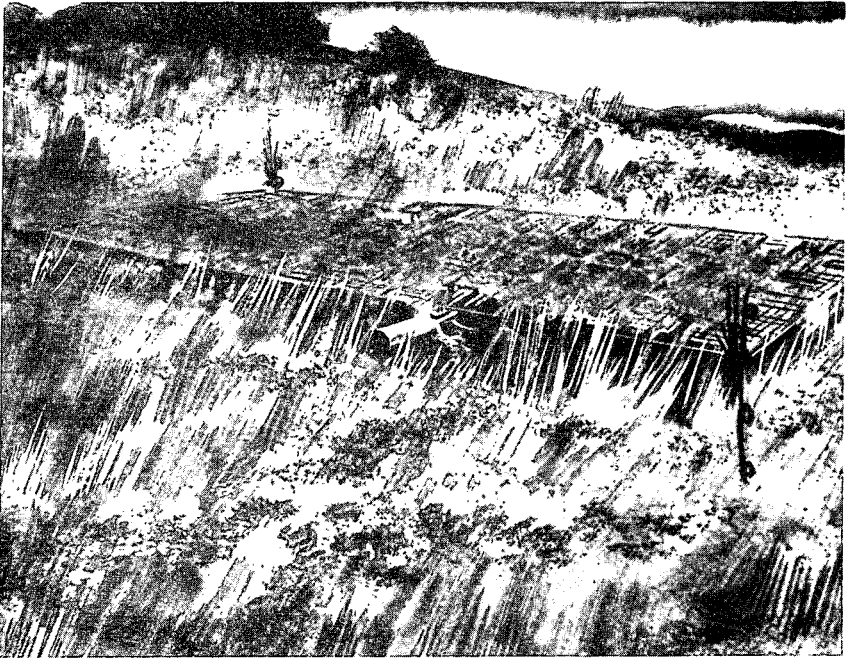

Figure 37. Flattop concealing firing position.

garnished with natural or artificial materials to blend with the surrounding terrain. When properly erected and garnished, the flattop conceals from vertical and high oblique aerial observation (fig. 37). The following points should be considered in planning the erection of a flattop:

a. Flattops must be parallel with the ground. On a hillside, an erected flattop is to follow the slope of the hill. A flattop covering a large area must have variations in the elevation to conform to the slope of the ground.

b. Flattops are suitable for flat-trajectory weapons such as machine guns.

c. Normally a flattop should be $1\frac{1}{2}$ to 2 feet above the top of the object to be concealed to allow for visibility and activity under the flattop.

d. The area under the flattop should be matched to its surroundings with sod, leaves, and other natural materials. Concealment is more complete if the object is toned to blend with the surroundings.

e. Large permanent flattops are to be strong enough to support the weight of men engaged in repair and maintenance of the flattop. The area to be concealed is staked off and wire or tape is installed to show the limits of the emplacement and to prevent breaches of camouflage discipline that will disclose the position. Access paths are constructed under cover or along natural terrain lines to prevent tell-tale tracks.

33. Height of Flattops

The closer that a flattop can be placed to the ground, the more chance it has to escape detection. A high flattop may not be disclosed in a single aerial photograph, but under stereoscopic examination it will appear to be floating in the air. Shadows cast by the garnishing of a high flattop can be seen. For complete concealment flattops should be no more than 3 feet above the general height of the vegetation at their edges. If the position does not permit this, the installation is to be dug in or the flattop is to be supplemented by slope nets or terracing.

34. Protective Area of a Flattop

A flattop should extend past the area to be concealed on each side by a distance equal to twice the height of the flattop above the ground. This provides a margin to protect from high-oblique observation and to allow for thinning the garnishing at the edges. The outer area of the net provides little concealment unless the net is used at ground level. Objects placed near the edge of the net must be concealed by a supplementary cover of vegetation, foliage, or sloped screens made from additional nets.

35. Screens

Road screens may be used to conceal actual or decoy roads from ground observation, character and extent of movement along a road (fig. 38), and turnoffs and loading points on roads at supply points and other installations. Only overhead screens are effective against aerial observation (fig. 39).

a. Screens for concealing roadblocks from ground observation may be made of any camouflage material; debris, vegetation, or properly

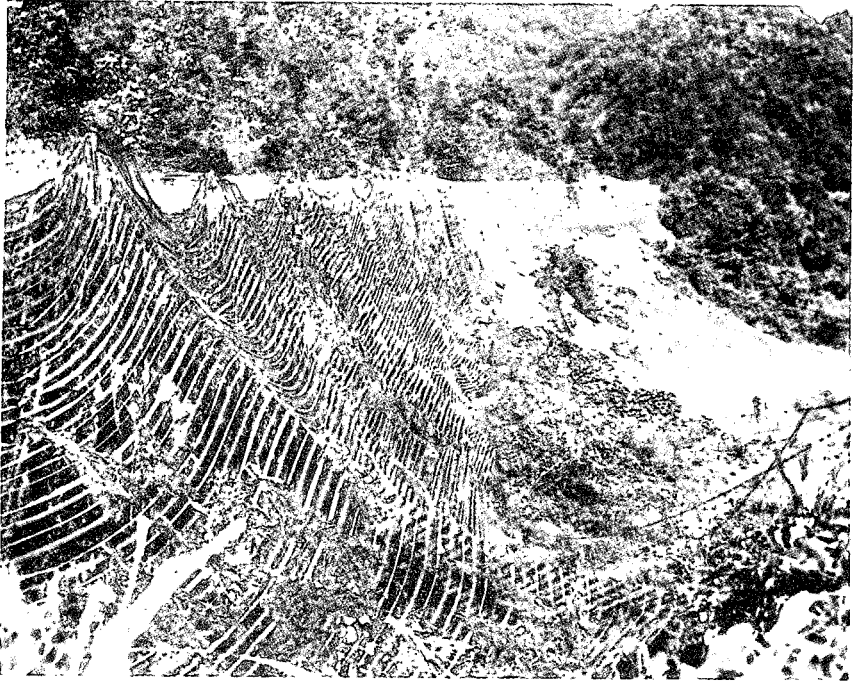

Figure 38. Screen concealing movement along road from ground observation.

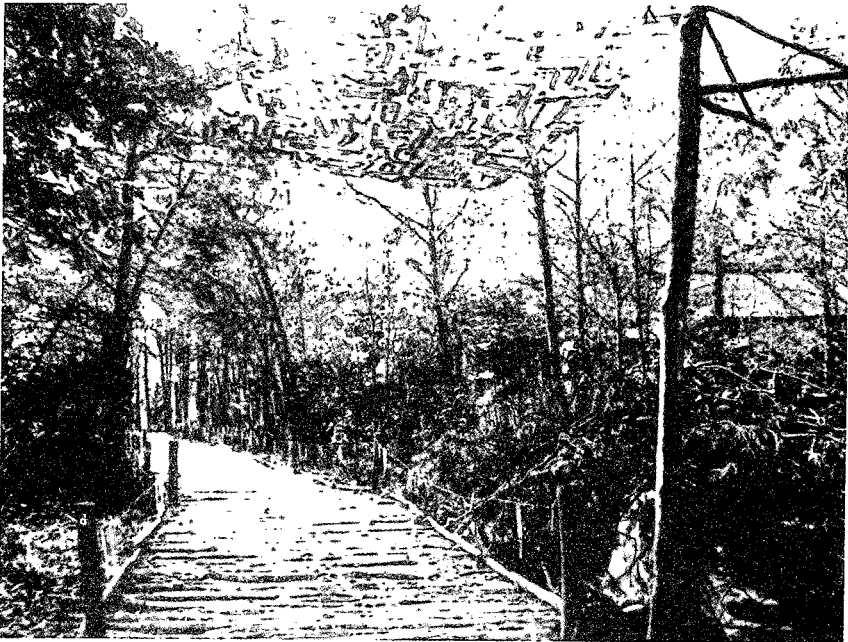
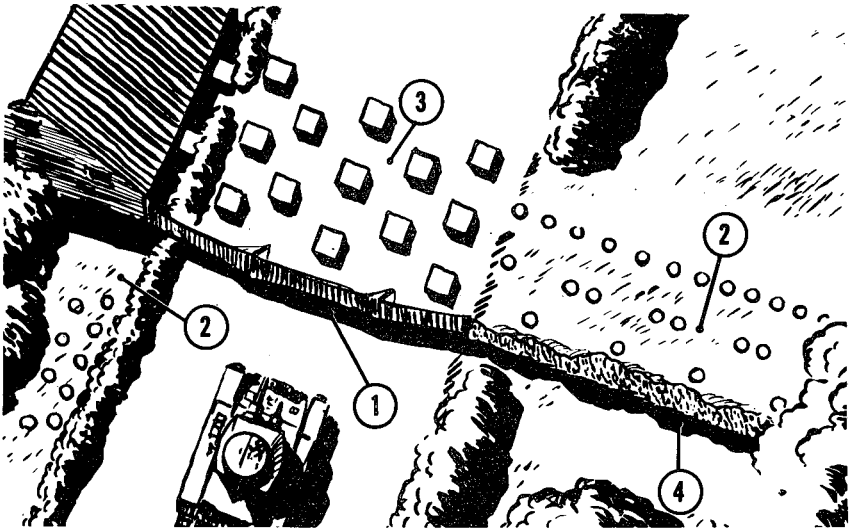

Figure 39. Overhead screen concealing road.

garnished artificial material. One technique is illustrated in figure 40. The purpose is to hide the block so that the enemy must make a choice either to crash the screen and risk what is behind it or to stop and investigate it. If he stops, he is vulnerable to fire. If he tries to run over it, he cannot take advantage of possible weak points in the obstacle.

b. Vertical screens to protect bivouacs from enemy patrols are made of natural materials blended with the background.



- | | |
|-------------------|-----------------------------|
| 1 Vertical screen | 3 Concrete blocks |
| 2 Antitank mines | 4 Screen on concertina wire |

Figure 40. Concealing a roadblock from ground observation.

c. Vertical screens have a further use as deceptive devices in barren areas, where they can mask gun positions from ground observation.

d. Another method of improving overhead concealment at such points is to pull branches and small trees together at the top and fasten them with wire or rope.

e. Sides may be added to a flattop and sloped gradually to the ground. These sides should not make more than a 15° angle with the net; otherwise, a regular hard "ridge" line will be formed where the sides join the large net and the sloped portion will differ in appearance from the horizontal part. They must be gradual extensions of the top to form a sort of inverted shallow bowl with a flat bottom. If the area to be covered is not too large, a dome-shaped slope screen can be constructed (fig. 41). The dome shape is acquired by adding uprights of intermediate height in line with the required vertical up-

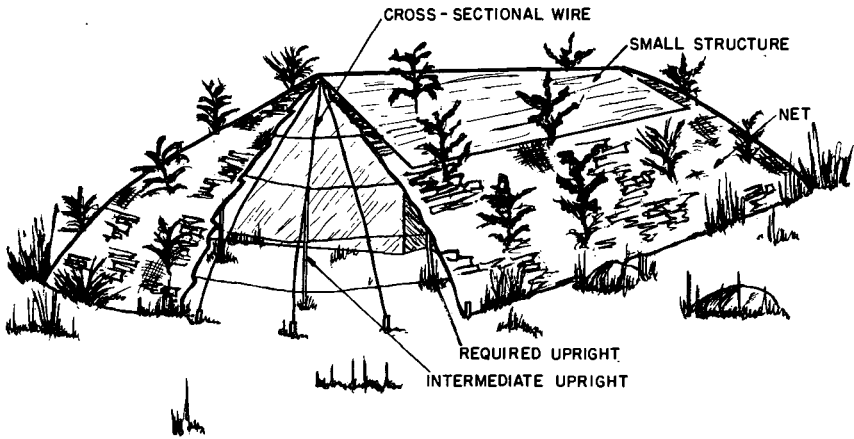

Figure 41. Cutaway drawing of dome-shaped screen.

rights and by running wire along the tops of these uprights, rising gradually from stakes in the ground on one side, up and across the middle of the curve, and down again on the opposite side. A uniform and even-sloping surface is obtained by the addition of cross-sectional or radial wires. There is little or no definite flat area in a dome type net. The sides slope continually to gradual curves to form an angle of 15° or less with the ground, again forming an inverted shallow bowl, but with a round bottom.

36. Smoke

Smoke is sometimes used to screen an operation such as a river crossing or to hide or reduce the visibility of large fixed installations such as railroad yards or docks.

a. *Methods of Smoke Screening.* The use of smoke to protect rear-area installations or activities requires production and maintenance

of large clouds or screens over a broad area. The most satisfactory method of accomplishing this, from the standpoint of economy of materials and operating personnel, is by the use of oil. Vaporization and condensation of special oils in a mechanical smoke generator produce a dense, persistent smoke with ample obscuring power to hide surface objects from aerial observation.

b. References. For further information on smoke, see appendix I.

Section III. MAINTENANCE OF NATURAL AND ARTIFICIAL MATERIALS

37. Pattern and Appearance

Camouflage training in the erection of drape nets and in the use of natural materials should include instruction in proper maintenance. Maintenance of camouflage structures, such as drapes, which are always larger than the objects they conceal, is another vital part of camouflage discipline (par. 12). If they are permitted to sag, fade, or otherwise change their original appearance, they may easily be more conspicuous than the unconcealed installation would be. In the same way, natural materials must be renewed before they noticeably wither or change color, which in summer may mean as often as twice daily. Seasonal changes in the colors of the terrain must be anticipated, and the colors of artificial camouflage materials changed accordingly, by regarnishing or repainting. Plans must be made well in advance and must be flexible because the time of change is variable and may come suddenly.

38. Control of Activities

Signs of activity are generally the results of essential routine actions. Camouflage discipline techniques are intended either to control the performance of those actions in such a way as to prevent visible changes in the appearance of the terrain or to make necessary camouflage changes to mislead the enemy observer or photointerpreter. Damage from accident or enemy action must be repaired without delay.

Section IV. DISRUPTION OF FORM

39. General

Disruption of form is accomplished by adding irregular outlines to regularly shaped objects and by using disruptive patterns of paint and other materials (fig. 42). Paint is the most commonly used material. Disruption of form is not a positive preventive against direct observation or aerial photography, but it aids in confusing the aim of a bombardier, tank gunner, or rifleman and in many instances will deceive an observer.

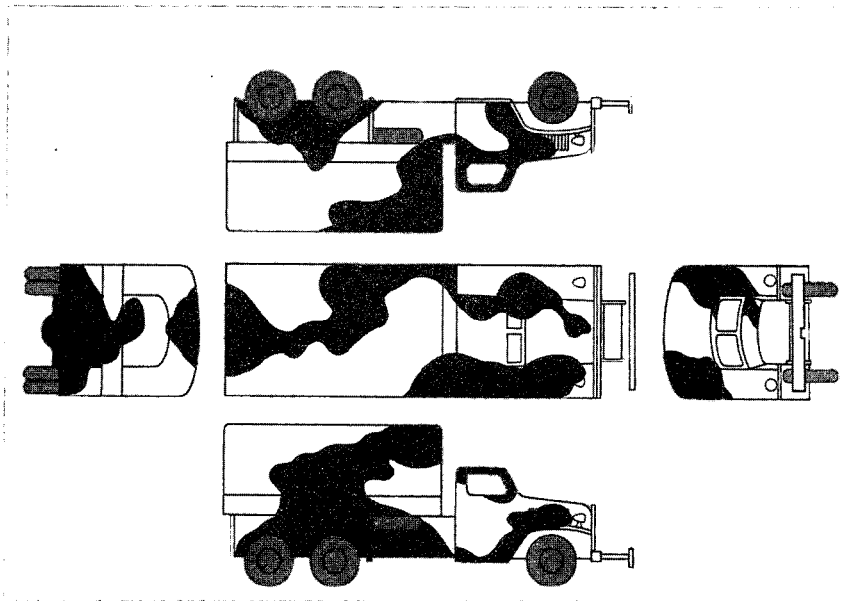

Figure 42. Disruptive pattern painting.

40. Silhouettes

Disruption of the outlines, shapes, and shadows of tents and temporary buildings is aided by the use of silhouettes usually attached to the edge of roof surfaces or tents. They must be irregular and conspicuously clear. Materials such as plywood or stiff chicken-wire-garnished frames have the necessary firmness and durability. Scaffolding, nets, or framed decoy structures are also used as described in FM 5-22.

41. Pattern Painting

a. In pattern painting, the object is painted 2 or 3 contrasting colors, applied in irregular shapes. Colors should be similar to the predominant colors in the object's surroundings. Objects are painted darker on top and lighter below, for the reason that upper parts receive and reflect more light. This principle is especially important in vehicle painting. Patterns should extend around corners and over vulnerable points.

b. There is no definite rule governing pattern sizes. They depend on the size of the object, the size and type of the surroundings, and the type and range of enemy observation. When seen from a distance small patterns blend into one overall color, and do not destroy the shape of the object. Small differences in color cannot be distinguished by aerial observers, and, therefore, small patterns are ineffective.

c. Painted patterns alone do not give reliable concealment. To be effective the object must be seen against the background for which the colors have been chosen.

d. Disruptive painting of vehicles is *tactical* protection. It is protective coloration intended to conceal vehicles in well-selected positions. The following basic color schemes are recommended for painting patterns on military objects:

- (1) *Temperate zone.* Olive drab, field drab (or other light color to match terrain), black.
- (2) *Desert.* Sand or earth yellow, earth red (or other light color to match terrain), black.
- (3) *Snow or ice area.* White, olive drab, or a combination of both colors depending on the color needed to blend with the predominant background color.

PART TWO
FIELD CAMOUFLAGE
CHAPTER 6
INDIVIDUAL CAMOUFLAGE

42. General

Individual camouflage is that personal concealment which a soldier uses in combat to surprise and deceive the enemy. The ground is the soldier's observation post, jumpoff point for attack, obstacle, route of advance, and means of fortification and protection. He must know how to use the ground for effective concealment (fig. 43). He adapts his dress for the best concealment while in the firing position, and carefully selects his routes between positions for as much concealment as possible (fig. 44). The simple principles in this manual have been battle-tested. If the soldier learns and practices them continuously in training, he will know what to do about concealment in battle.



Figure 43. Individual concealment in a firing position.

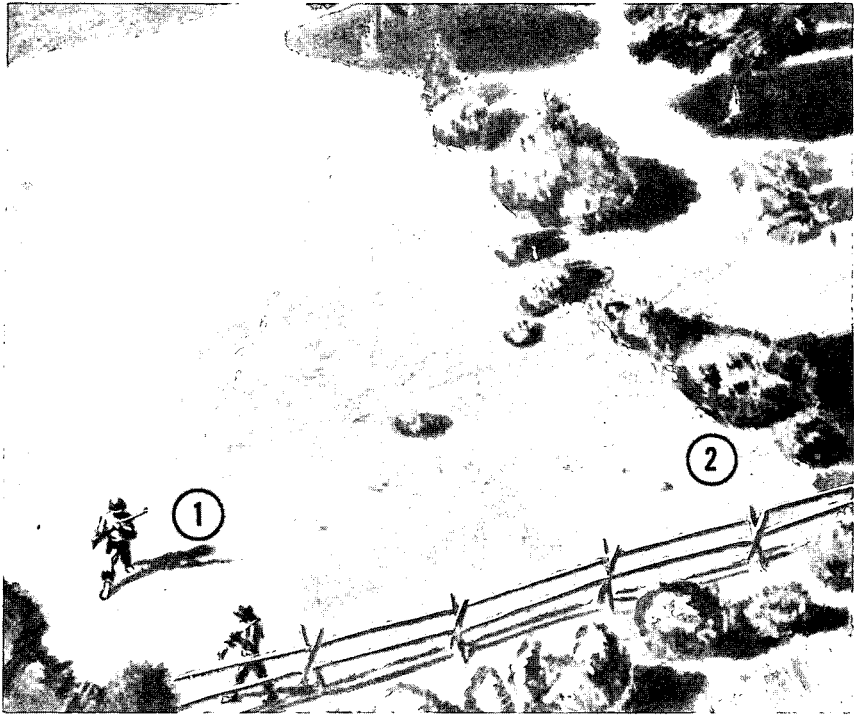

1 Unconcealed route of approach 2 Route affording best concealment in movement

Figure 44. Selection of route in advancing.

43. Enemy Observation

Camouflage activities of the individual are designed to deceive two types of enemy observers—ground observers and air observers. Views from the ground are familiar and commonplace, but views from the air are different. Many things that are invisible from the ground can be seen from the air. The differences in appearance of different types of terrain views from the air as compared with their appearance from the ground can be used as a basis for achieving camouflage. Methods of protection from observation from the air can be learned in this manner. It can be expected that the enemy will use electronic surveillance devices, such as radar, to increase the range of view and to penetrate screening devices.

44. Concealment in Various Geographic Areas

a. General. Effective concealment of the individual depends largely on the choice and proper use of background. Background varies widely in appearance, and the soldier may find himself in a jungle setting, in a barren or desert area, in a farmyard, or a city street. Each location will require individual treatment because location governs every concealment measure taken by the individual.

Clothing which blends with the predominant color of the background is desirable. The uniform is designed to be as inconspicuous as possible under most conditions. There will be occasions, however, when the uniform color must be altered to blend with a specific background. The color of the skin must receive individual attention and be toned to blend with the background (fig. 45). Equipment must be treated similarly; shine must be eliminated and contrast in tone reduced as



1 Wrong

Figure 45. Skin toned down.

much as possible. Practice during training should be continued until the individual automatically blends with his background, avoids contrast, and does not present a silhouette.

b. Individual Camouflage (Jungle). Certain individual preventive measures in the jungle are most important. The close proximity of the enemy makes sound, light, and movement revealing and dangerous. Special care is necessary in moving forward to avoid



2 Right

Figure 45—Continued.

springing enemy traps or otherwise giving warning. Background silhouette is to be avoided. Skin is to be covered to eliminate shine. Metal gear is to be toned down to eliminate shine (fig. 46).

c. Individual Camouflage (Snow).

- (1) Troops operating in open areas covered with snow should wear the complete white camouflage snowsuit (fig. 47). If the snowsuits are not available a snow cape may be fashioned



Figure 46. Shine.

from white cloth or white osnaburg. Individual and crew-served weapons should be whitewashed or painted white with a semigloss paint or wrapped with strips of white cloth. Normally if white camouflage is necessary the helmet will be covered by the white parka hood which eliminates the necessity for whitening the helmet. Figure 48 illustrates how inconspicuous a camouflaged soldier appears as compared with a soldier without a snow cape.

- (2) Troops operating in a heavily wooded area under normal conditions require only the white camouflage pants (fig. 49).

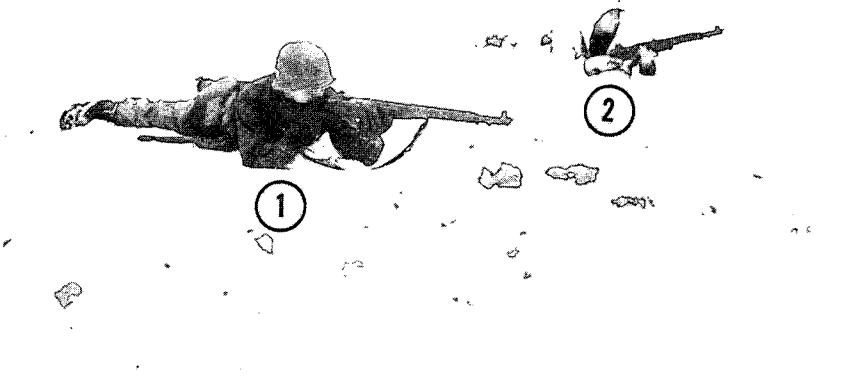

Figure 47. Troops wearing snowsuits.

However, following or during a heavy snowfall when the trees are well covered with snow, the wearing of the complete white camouflage suits is necessary to properly blend with background (fig. 50). Auxiliary equipment, such as packs, should be covered with white material or painted white. Ski equipment should be painted white because the skis are kept in snow even when men are in a static defense position.

45. Helmet

The outline of the helmet is one of the striking characteristics of the soldier's equipment. Its curved shape is familiar to the enemy. One of the first steps in individual camouflage is to disrupt the



1 Without snow cape 2 With snow cape

Figure 48. Individual with and without snow cape.



Figure 49. Individual concealed in forest area.

shape of the helmet and thereby eliminate the strong, straightlined shadow that it casts. The following ways of disrupting the shape of the helmet and reducing its shine or contrast can be employed. The choice of method depends on the tactical situation and time and materials available.



Figure 50. Individuals after heavy snowfall.

a. Paint. A disruptive paint pattern is to be used on the helmet (fig. 51). Care is to be taken to carry the pattern across the curved lines to the edges, especially those seen from the front.

b. Bands. Rubber bands can be used as holders for garnish of natural materials (fig. 52). A band cut from a discarded inner tube makes a good expedient for the issue band. Bands are not to be

placed too high on the helmet. Strips of cloth are acceptable expedients. When natural materials are not available or not advisable for garnish, the shape of the helmet is to be disrupted with bow ties (fig. 53) made of burlap or osnaburg. They should be small enough so that they do not readily catch in bushes or branches and large enough to disrupt the form of the helmet.

c. Helmet Covers. An improvised cover can be made for the helmet from a circular piece of osnaburg, burlap, or other coarse-weave cloth. Burlap being the best, helps to tone down the color of the helmet, disrupts its shape, and eliminates shine. The circular piece should be 20 inches in diameter. A 1-inch hem is sewn around the

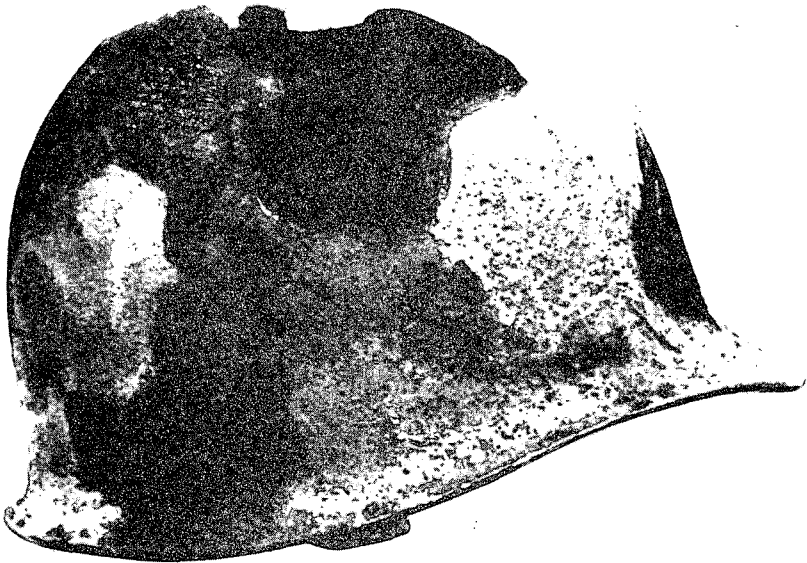

Figure 51. Disruptive painting applied to steel helmet.

edge, a tape or drawstring is pulled through the hem, and the cover is pulled loosely onto the helmet. It should be painted or smeared with mud to break up the continuous tone. Slits are to be cut in the cover to allow for the insertion of foliage (fig. 54) as in the issue cover. No matter what kind of helmet cover is used, it is incomplete if the shadow underneath the helmet is not broken up by arranging bits of foliage or other garnish so that pieces of it hang over the rim of the helmet. Small irregular fringes of cloth, similarly arranged, will accomplish the same purpose and will, at the same time, keep gnats and mosquitoes away from the face and neck (fig. 55).

46. Skin Tonedown

The contrast in tone between the skin of face and hands and that of the surrounding foliage and other background must be reduced. The skin is to be made lighter or darker, as the case may be, to blend with the surrounding natural tones. The issue face paint stick may be used whenever natural materials are not available. The shine areas are the forehead, the cheekbones, nose, and chin. These areas

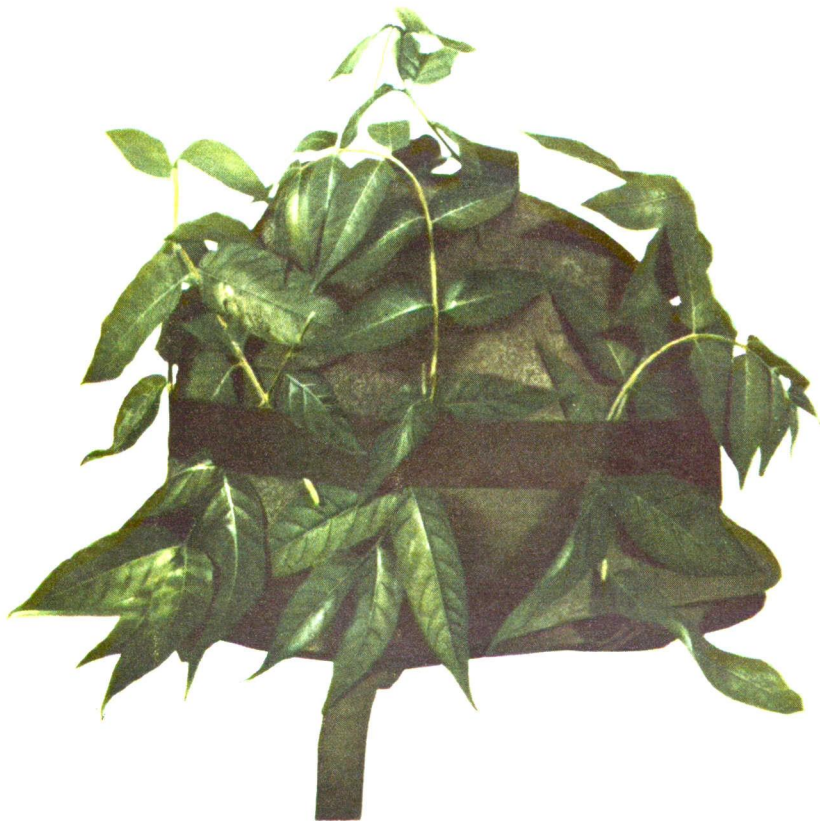

Figure 52. Helmet concealed by use of natural material held in place by rubber band.

should have a dark color. The shadow areas such as around the eyes, under the nose and under the chin should have a light color (fig. 45). The hands, arms, and any other exposed areas of skin must also be toned down to blend with the surroundings. Burnt cork, charcoal, lampblack, and mud can all be used as toning materials. Because soils contain harmful bacteria, a medical officer will determine which soils are safe for use. A mesh mosquito face net, properly toned down, is an effective method of breaking up the outlines

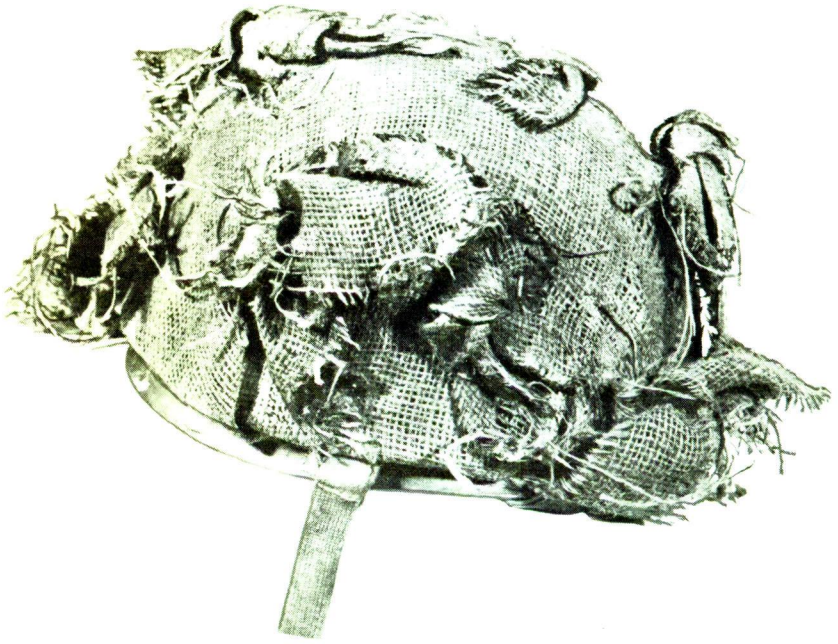

Figure 53. Bow ties used to break up the shape of the helmet.



Figure 54. Shape of helmet disrupted by natural material.

of the face and ears. Such a net can be dyed in strong coffee when manufactured dye is not available.

47. Canvas Equipment

Clean canvas equipment is correct for inspections, but in combat such equipment violates the principles of camouflage (1, fig. 56). Patches of higher or darker color are easily spotted. One of the first tasks in dressing for the job of fighting is to reduce the contrast in tone between the equipment and the surroundings. This will re-

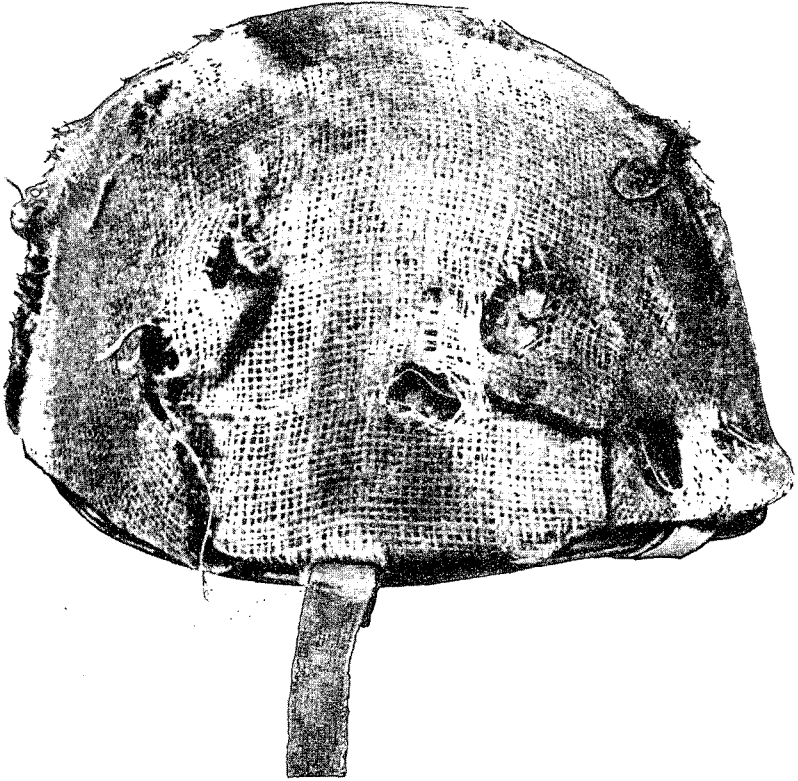

Figure 55. Helmet camouflaged with burlap cover.

quire darkening the equipment in some instances and making it lighter in tone in others (2, fig. 56). Reducing tone contrast can be done with paint, cloth, mud, charcoal, or any other suitable substance that is available.

48. Camouflage Clothing

Individual concealment requires only a little planning and thought, and the use of materials at hand. This applies to camouflage for clothing as well. The soldier can make his own camouflage suit,



1 Light equipment producing vivid contrast 2 Darkening equipment aids concealment
Figure 56. Reducing tone contrasts between equipment and the surroundings.

adapting its color and form to the situation and the terrain. Any coloring material can be used: Dyes, crankcase oil, or even a mixture of mud and cup grease. The important thing is to make the clothes look more like the terrain than like a uniform. The personal camouflage is just a *beginning* in the job of concealment. Camouflage clothing and camouflaged equipment alone won't conceal, but must be used intelligently in accordance with the basic principles of camouflage and the principles of scouting and patrolling. The following paragraphs of this chapter explain how to take advantage of terrain with the use of camouflaged clothing.

49. Snowsuits

The Army snowsuit is a two-piece garment, plain white, designed to blend with a white or mottled white and black background (fig.

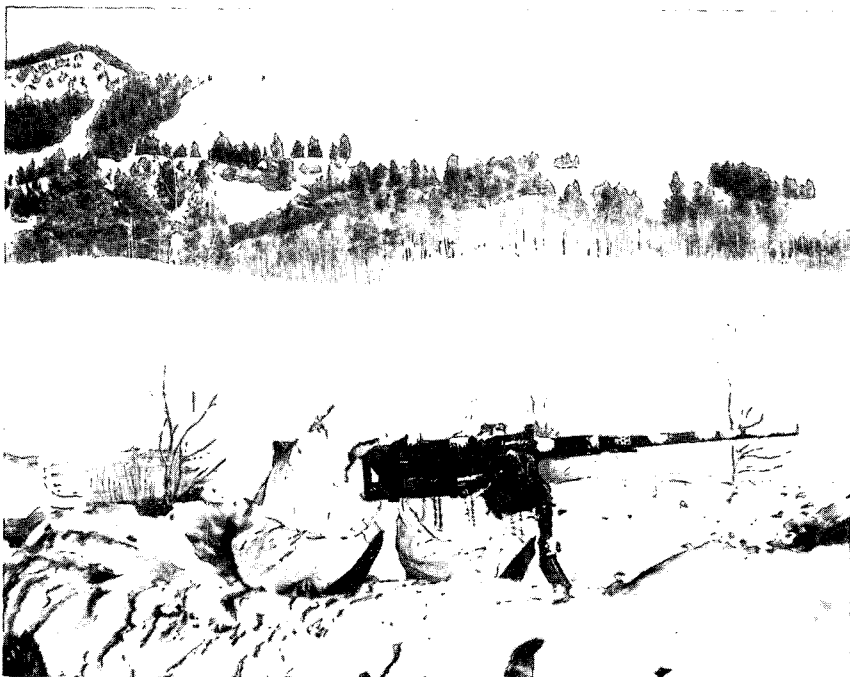

Figure 57. View of snow country.

47). Because snow country is not all white (fig. 57), shadows and dark objects appear darker than usual. The snowsuit cannot conceal the small patches of shadow caused by the human figure, but that is not necessary if the background, too, contains numerous dark areas. If the background does not contain numerous dark areas, maximum use is to be made of defiles, snowdrifts, and folds in the ground to aid the individual concealment.

50. Blending With the Background

Losing the body's silhouette in the silhouettes of other objects in the background is accomplished by making use of the shadows in the background. The soldier should be constantly aware of these two factors, *silhouette* (fig. 58) and *shadow* (fig. 59). From a concealment point of view backgrounds consist of terrain, vegetation, manmade objects, sunlight, shadows, and color. The terrain may be flat and smooth or it may be wrinkled with gullies, mounds, or rock outcroppings. Vegetation may be dense jungle growth, or no



Figure 58. *Silhouette.*

more than small patches of desert scrub growth. The size of man-made objects may range from a signpost to a whole city block. There may be many colors in a single background, and they may vary from the almost black of a deep woods to the sand pink of some desert valleys. Blending means simply the matching with as many of these backgrounds as possible and the avoidance of as much contrast as possible (fig. 60). If it is necessary for a soldier to expose himself in front of a contrasting or fixed background, he must be aware of his position and take cover in the shortest possible time. The next point to which he will move for concealment must be selected in advance and reached as quickly as possible.



Figure 59. Shadow.

51. Silhouette

Although the soldier shown in figure 61 blends with the ground, he is sharply silhouetted against the sky. Such clearly defined edges must be avoided. The correct way to look over the bank is from the midst of objects that are irregular in shape and that can conceal (fig. 62).

52. Action at Night

As in the daytime, silhouette and background are still the vital elements in concealment. A silhouette is always black against a night sky, and care must be taken at night, as in the daytime, to keep off the skyline. On moonlit nights the same precautions must be taken as in daylight. It should be remembered that the position of the

enemy observer, and not the topographic crest, fixes the skyline. At night sound is an amplified, revealing signal. Movement must be careful, quiet, and close to the ground. If the *pop* of a flare is heard before the illuminating burst a soldier must drop to the ground instantly and remain motionless. If he is surprised by the light, he must freeze in place, with his face down.

53. Movement

Routes must be carefully chosen, whether by day or by night. Screens, backgrounds, and shadows must be used to the fullest advantage. A daylight route is shown in 1, figure 63. This choice of route assumes that there is fairly adequate concealment offered by undergrowth and shadow. Under favorable conditions it is possible



Figure 60. Blending with background.

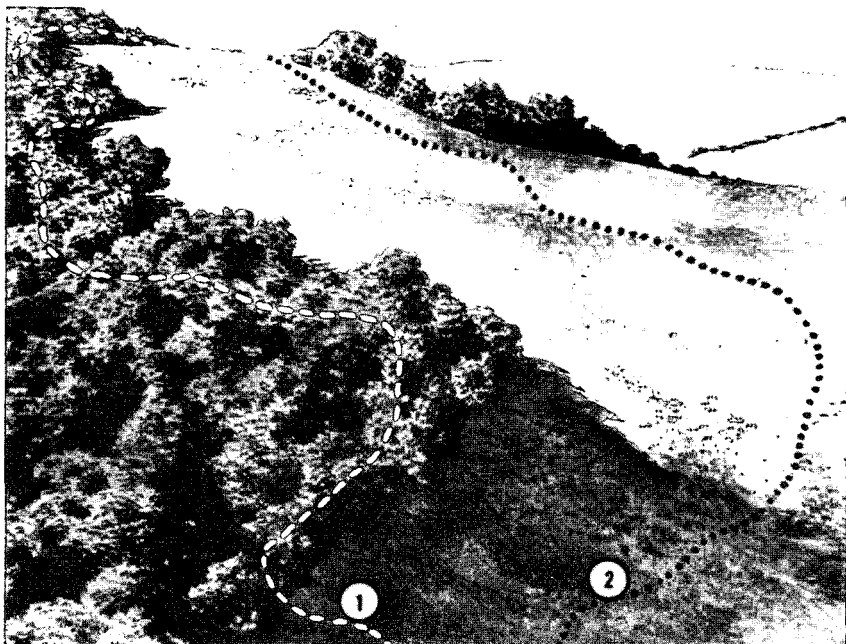

Figure 61. Improper concealment of observer.



Figure 62. Proper concealment of observer.

for the enemy to see as much as 100 yards into an open woods. In the case of light undergrowth the route must be farther into the woods for safety. Woods with medium undergrowth also furnish many good observation points. Heavier undergrowth is an obstacle to movement, and, where rapid movement is more important than full concealment, the outside edge of the woods may be the most desirable route. Where only a hedge or fence is available, movement is to be in the shadow of the hedge or fence. The route shown in 2, figure 63, would be used on a dark night only. A dark night furnishes shadow, and a route is also chosen to provide concealing background



1 Daylight route

2 Route on a dark night

Figure 63. Selection of routes.

and to avoid the skyline. On bright, moonlit nights the shadow along the edge of the woods is probably the best route. It is difficult to walk quietly in the woods at night. Low places in the terrain offer temporary concealment. In any plan the mission must always be considered first, then the other factors, ease of movement, amount of shadow, and types of background. Each factor should be evaluated and the most feasible route determined. Targets are easily recognized at night because natural materials reflect a large quantity of infrared waves and artificial materials such as the uniform and other materials do not. The only protection against detection at night is to keep close to the ground and with the use of natural materials in concealing position and movement.

54. Points to Remember

The following instructions summarize this chapter and are basic to good individual camouflage. As such they should be followed at all times. This paragraph should be used as a checklist to determine the completeness of individual camouflage application.

a. Concealment is to be effective and protect from hostile observation from the ground view as well as from the air view.

b. Natural terrain lines are to be used for the advance whenever possible.

c. Varying speeds are to be used in moving: quickly across open areas, slowly along natural lines of concealment, and alternately fast and slow across neutrally colored areas.

d. The area in front is to be observed carefully from the concealment of low bushes; look through or under them, not over.

e. Every possible feature of the terrain is used for concealment.

f. A place is found in which observation to the front is possible; a good field of view is important.

g. The next stopping point is located and the best route to it is determined before starting out.

h. A silhouette against the sky is to be avoided. When it is necessary to cross the skyline at a high point in the terrain, crawl to it and approach the crest slowly using all natural concealment possible. How the skyline is to be crossed depends on whether it is likely that the skyline at that point is under hostile observation. When a choice of position is possible, the skyline is crossed at a point of irregular shapes such as rocks, debris, bushes, or fencelines.

i. Every effort is to be made to reduce tone contrast and eliminate shine. Generally speaking, these are the two features which set the individual off from his surroundings: the shine of his equipment and the difference in tone between his skin and the background. This is especially true at night.

j. A position is chosen with easy access to and from a point of advantage for the individual or the unit. The appearance of the place is to be kept as unchanged as possible. Every bush, shrub, tree, and pile of debris must be occupied in such a manner as to leave it undisturbed. Changes in pattern and motion in parts of a normally static landscape are attention-calling signals to the trained observer. The individual must come and go without advertising his presence. When leaving a stopping point it should be left as it was before, without signs of former occupancy.

CHAPTER 7

FIELD FORTIFICATIONS

Section I. EMBLACEMENTS

55. Site Selection

Proper site selection is the most important consideration in planning field fortifications. However, to serve in their fullest capacity, field fortifications and obstacles are to be camouflaged in such a



Figure 64. Camouflage task made easier by proper site selection.

manner that they are a complete surprise to the enemy. The camouflage task is made easier by proper site selection (fig. 64).

a. Field fortifications are sited to take advantage of the terrain and at the same time permit camouflage which is vital for the security and stability of these installations. A position is selected that will not require a change in the appearance of the terrain. Consideration of the camouflage aspect will save time and labor in effecting good concealment. To reduce ground observation, a position should be located with a good background so that occupants are not silhouetted (fig. 65). Field fortifications or obstacles cannot be concealed solely by siting, but when proper advantage is taken of the

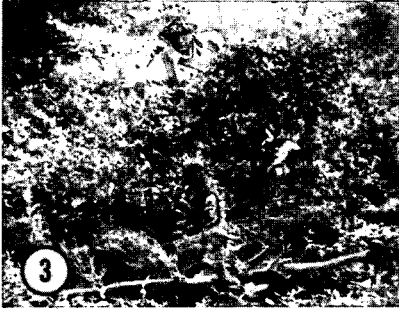

- 1 Position located with good background
- 2 Framework for cover added
- 3 Garnishing with natural materials
- 4 Completed position; ready for firing

Figure 65. Mortar position sited for good camouflage and support of unit mission.

terrain, positions can be rendered inconspicuous from ground observation. To reduce the possibility of aerial observation, regular geometric layouts of positions are to be avoided, and decoys and dummies are to be used to confuse the enemy. Positions are to be located under trees, bushes, or in dark areas of the terrain. However, locations should not be isolated to the extent of being a landmark or an aiming point (fig. 66).

b. Postponing erection or construction of field fortifications is often the best way to camouflage a position. However, where the enemy has nuclear employment capabilities, the erection or construction is not to be postponed.

56. Camouflage Construction

a. *General.* Before any excavation is started, all natural materials necessary for camouflage construction, such as turf, sod, leaves, forest humus, or snow are removed (fig. 67). This material is placed or scraped aside, so as not to interfere with the digging of the position, and replaced over the spoil when the work is completed (2, fig. 68). Spoil that is not used is carried away (1, fig. 68), and dumped in a concealed place such as under bushes and low trees. Concealment is vital during camouflage construction. To prevent detection

of camouflage construction that has little or no overhead cover, camouflage nets are suspended above the position (fig. 69). The nets are placed so as to permit unhampered excavation work. Workers confine their activities to the area beneath the camouflage. (For

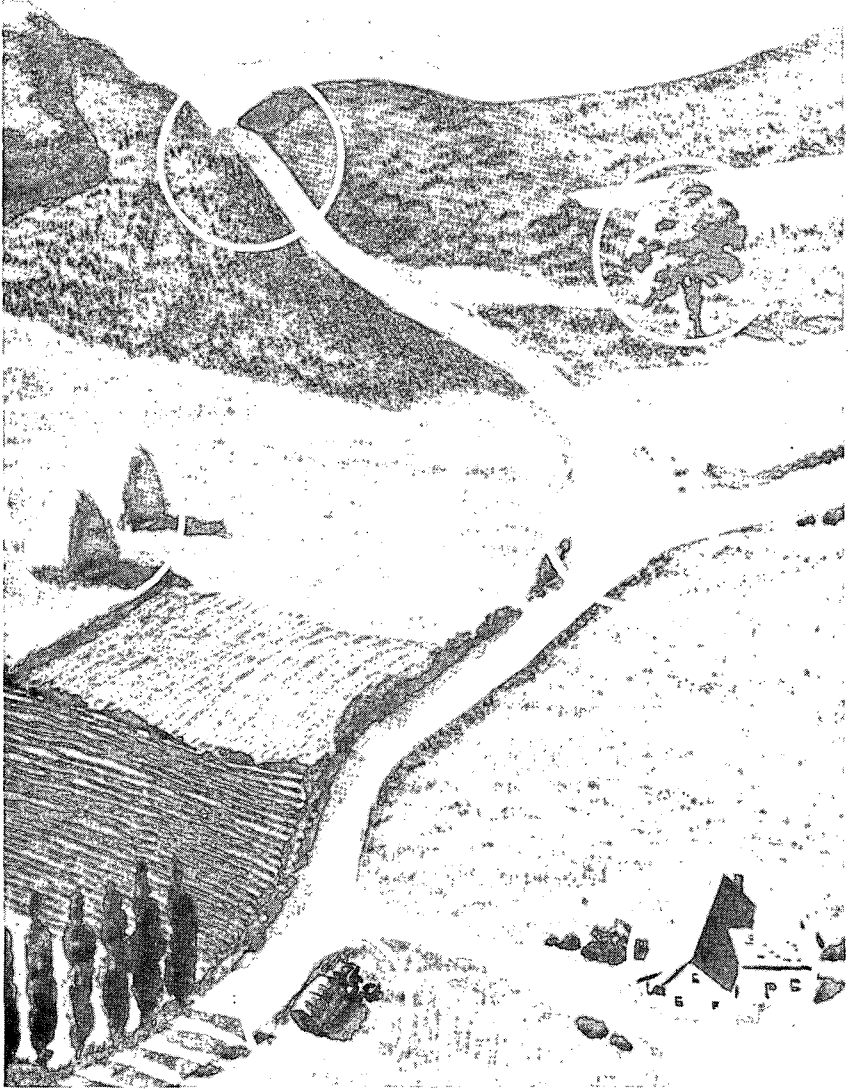

Figure 66. Typical isolated landmarks.

additional information on nets, see ch. 12.) Construction of tall objects such as observation towers or water towers in predominant snow areas, desert or barren areas, or sparsely vegetated areas is to be avoided.

b. Wooded Areas. Positions in wooded areas are sited to take advantage of natural concealment. Full use is made of natural materials, such as boughs of trees, grass, and other forest vegetation (figs. 70 and 71). Constant maintenance of the camouflage is necessary to keep the position looking natural (fig. 72).

c. Desert Areas. Field fortifications in the desert must take advantage of the irregular terrain pattern, terrain depressions, and the sparse vegetation that is available. Shadows are a greater threat



Figure 67. Removing natural camouflage material before construction of position.

in barren sandy desert areas than in other areas. Camouflage covers (par. 57) can be used to good advantage.

d. Jungle Areas. Abundant vegetation is available for camouflage construction in jungle areas. Because of this abundant vegetation, observation is close range and, therefore, more individual effort is required. Foliage is preserved when fields of fire are cleared by selective cutting and trimming of vegetation. Wanton slashing will draw immediate attention to any position (figs. 73 and 74).

e. Snow Areas. The individual should take advantage of snowbanks, defilades, and lea or sheltered areas of large objects (figs. 75 and 76). Camouflage covers (par. 57) may be used to provide a

base for falling snow which will increase the concealment of the position.

57. Camouflage Covers

Camouflage covers are essential for positions that cannot be sited under natural concealment and are a valuable aid in preventing detection of the position. Natural materials native to the site are used to a good advantage (fig. 77). Artificial or manufactured material may be used if garnished or pattern-painted to match terrain features. Covers made from these natural or artificial materials for hasty field fortifications are light in weight so that they can be removed easily (fig. 78). Firing openings are provided for in the cover.



① SPOIL BEING CONCEALED CORRECTLY



② SPOIL BEING REMOVED CORRECTLY

Figure 68. Spoil.



Figure 69. Work being done on bunker, using net to conceal activity.

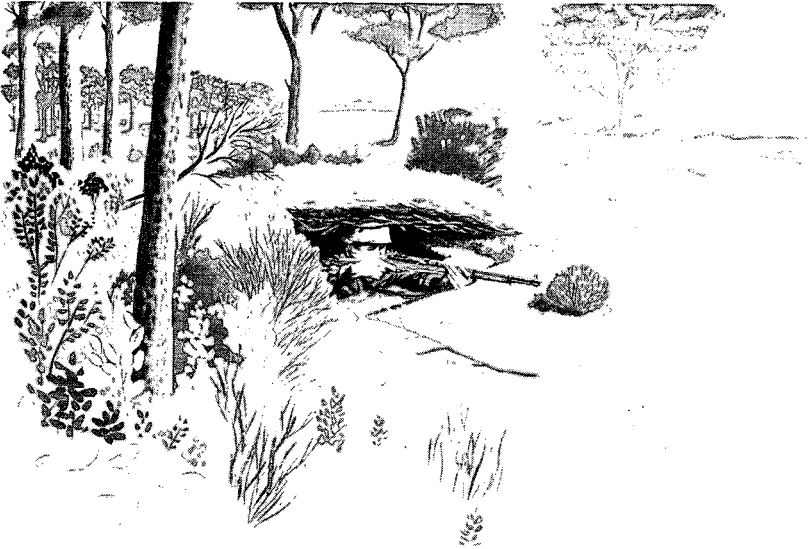

Figure 70. Concealed foxhole.

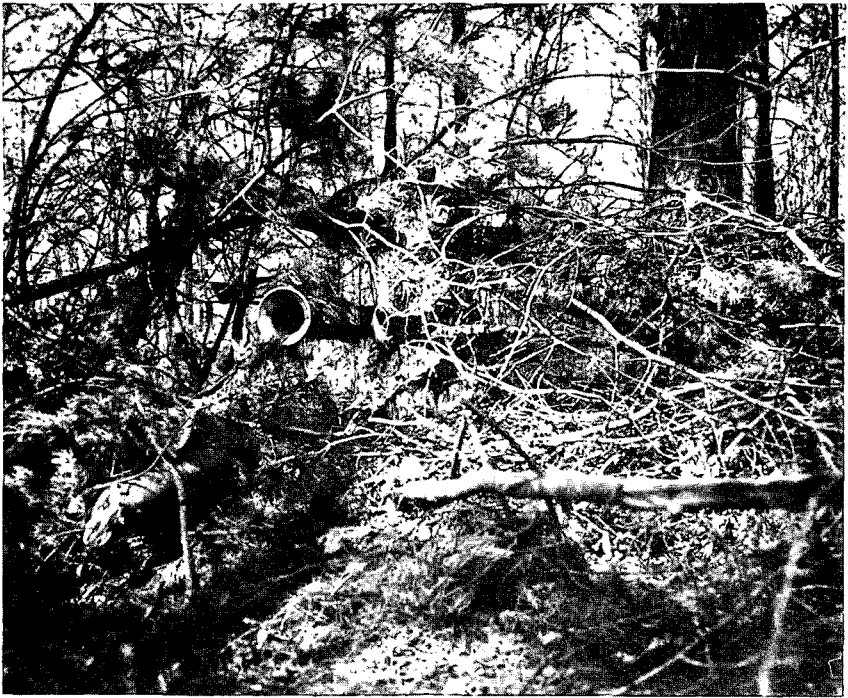

Figure 71. Concealed weapon emplacement.

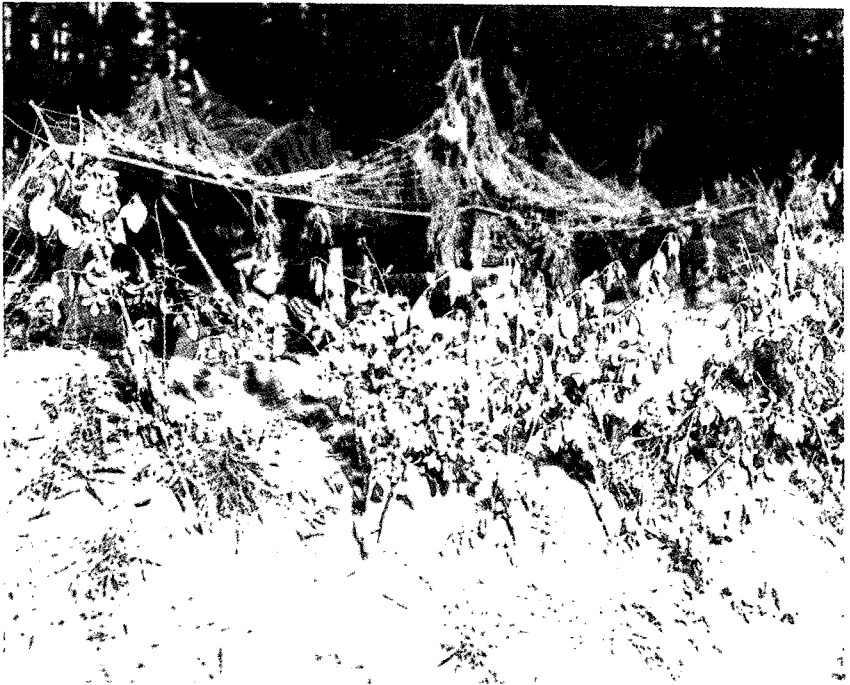

Figure 72. Withered plants and grass that need maintenance.

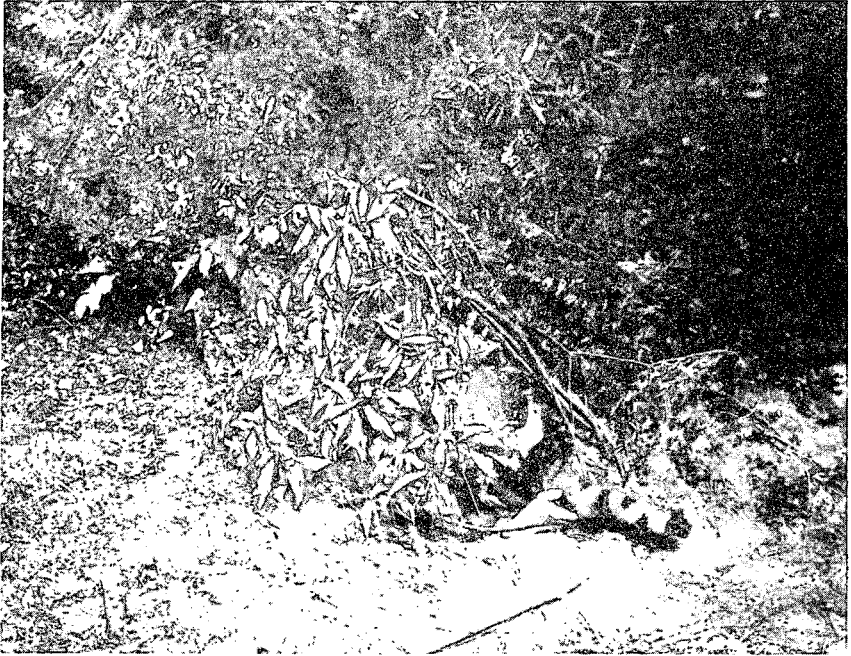

Figure 73. Foxhole in jungle.



Figure 74. Dugout in jungle.



Figure 75. Emplacement in snow area.



Figure 76. Foxhole in the snow.



Figure 77. Cover of natural material.



1 Net closed over position

Figure 78. Cover made from net garnished with natural and artificial materials and easily dropped for firing.

a. Foxhole Covers. The foundation of a foxhole cover (fig. 79) is a flat or round frame shaped from short branches bound together with available materials. Covers of burlap, corrugated iron, or wood may be used for the foxhole (fig. 80), but any type of cover used should be kept looking natural to blend with terrain patterns.

b. Emplacement Covers. Emplacement covers are constructed on a much larger scale. Due to the size of the position, sturdier materials are used for the frame to support a greater amount of natural camouflage such as large plants, limbs of trees, or snow (fig. 81). Flattop or drape nets are also used to good advantage if natural materials are not available or the cutting of natural materials would reveal the position (fig. 82).



2 Net open for firing

Figure 78—Continued.

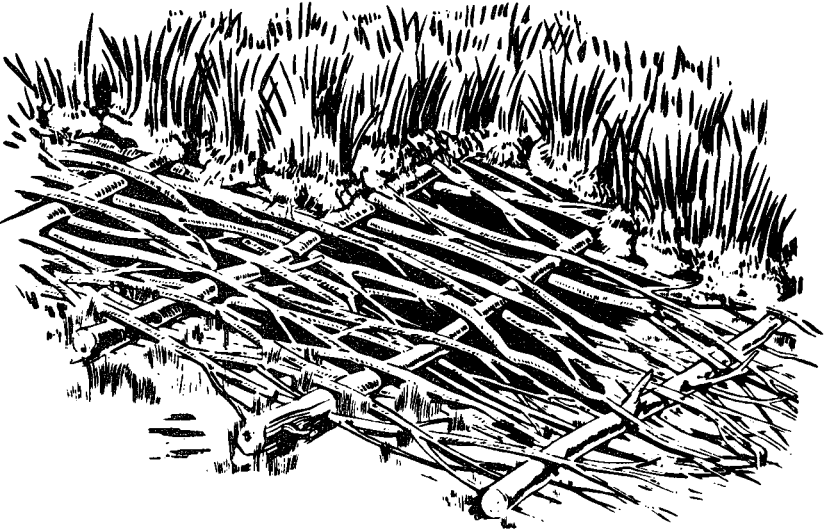

Figure 79. Foxhole cover.

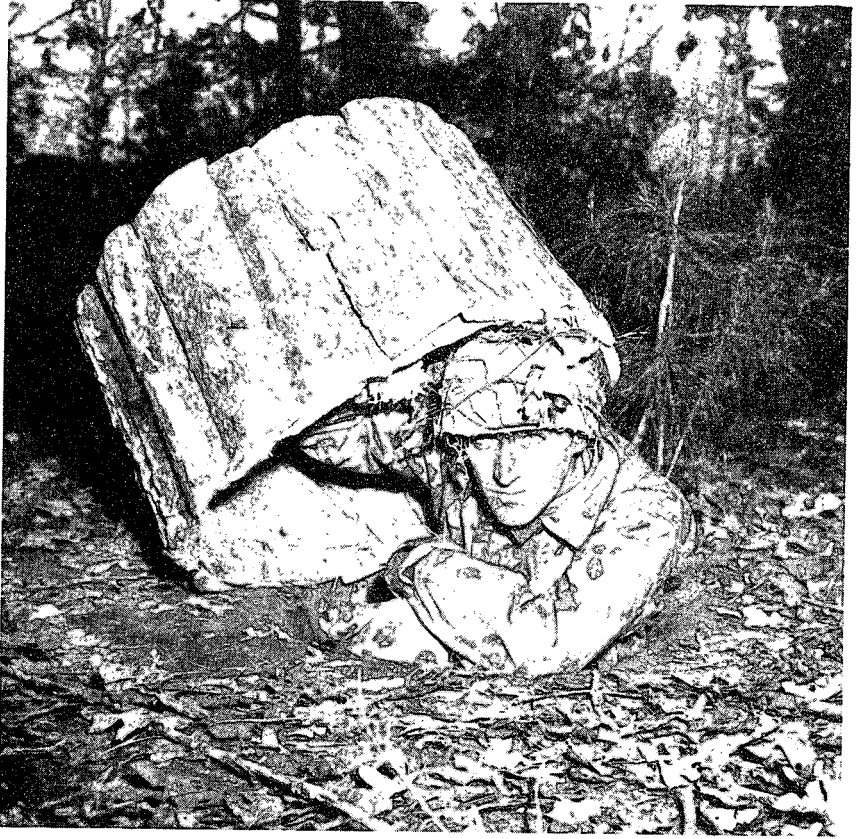

Figure 80. Foxhole cover made from burlap and the bark of a tree.



Figure 81. Machine gun emplacement using logs to support natural camouflage.



Figure 82. Emplacement using net cover.

Section II. INDIVIDUAL WEAPONS

58. Weapon Outline

The individual weapon must be concealed to complete the camouflage of a position. Weapon outline and shiny surfaces are the two factors involved in concealment of the weapon by camouflage. The rifle, carbine, machine gun, and recoilless and antitank weapons have distinctive outlines that are easily identifiable (fig. 83). Conceal-

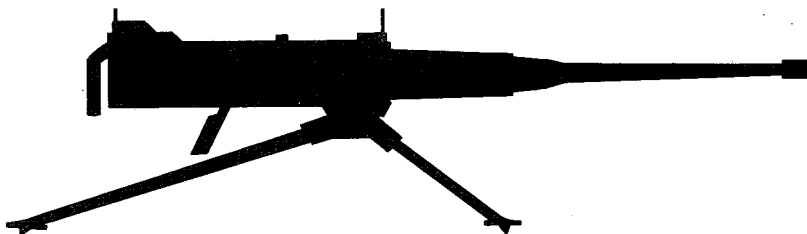

Figure 83. Silhouette of machine gun.

ment of the weapon by digging it in to present a low silhouette or by use of nets or natural cover are excellent methods. However, the tactical situation does not always permit sufficient time for these methods. Therefore the weapon outline has to be concealed by other means. One of the simplest ways to distort the outline of the weapon is by wrapping it with standard burlap garnishing or strips of cloth (fig. 84) dyed to match the surrounding terrain. Foliage placed on various parts of the weapon is another field expedient but is difficult to maintain when the weapon is operational. Pattern painting of

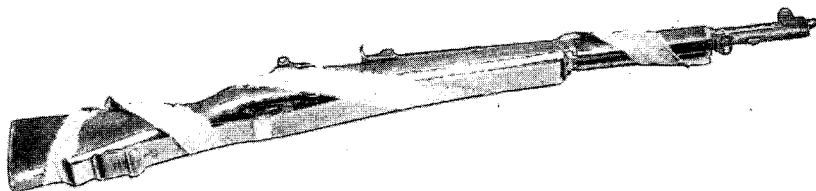

Figure 84. Rifle wrapped with cloth.

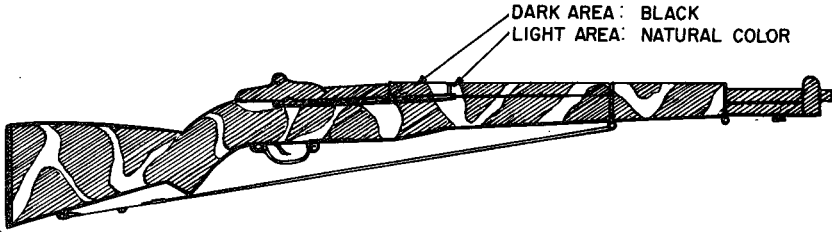

Figure 85. Rifle pattern painted.

the weapon (figs. 85 and 86), using colors that blend with terrain features, is another excellent method of camouflage used to distort the outline of the weapon. Any type of camouflage used must not interfere with the tactical effectiveness of the weapon.

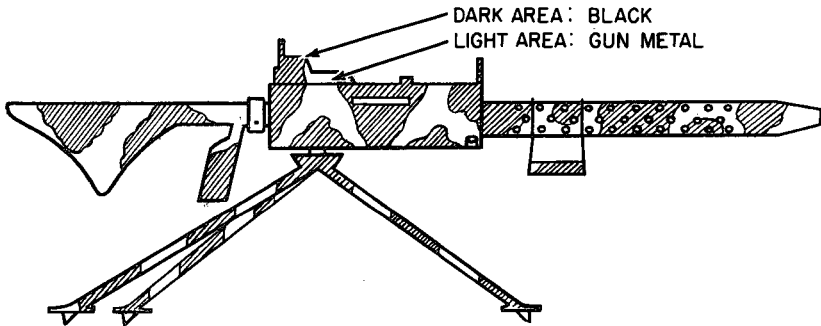

Figure 86. Machine gun pattern painted.

59. Shiny Surfaces

Shiny surfaces of the weapon can be concealed by various field expedients; cloth and paint, mentioned above, not only distort outline but can also be used to cover the shiny surfaces of the weapon. Mud or lampblack is also used to cover these surfaces (fig. 87). Mud used must dry to the desired color. Care must be exercised in the application of the mud to prevent stoppages in the sighting and firing of the weapon.

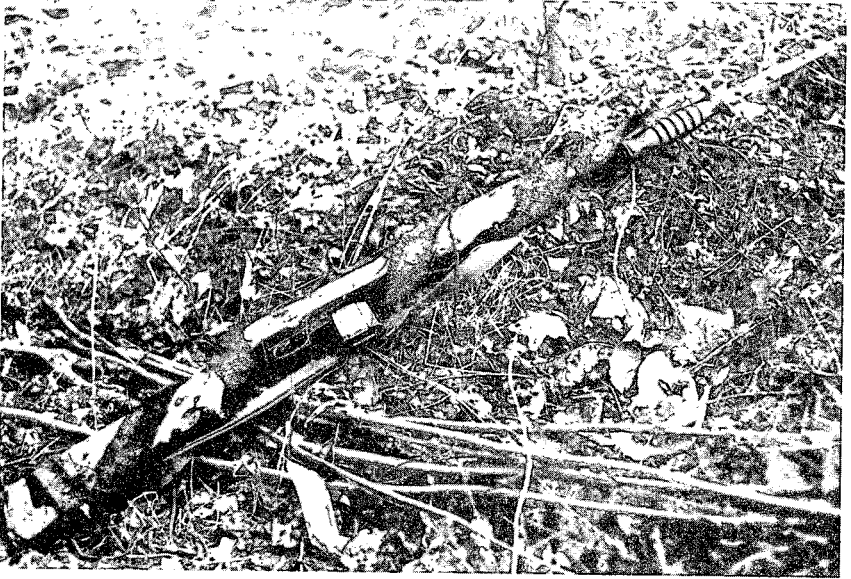

Figure 87. Covering shine on weapon with mud.

CHAPTER 8

VEHICLES

60. General

Application of the basic camouflage principles outlined in chapter 3 are just as important in concealing vehicles as preventive maintenance is to the operation of the vehicle.

61. Tracks

Tracks of vehicles are especially revealing to the aerial observer and the interpreter of aerial photographs. Single tracks of vehicles and the gradual turn of the track of tanks are clearly visible. Tracks reveal type, location, strength, and even intentions of the unit. Responsibility for maintaining the normal appearance of the terrain rests with the operator or driver of the vehicle. Tracks should follow closely and be parallel to hedge lines, fence lines, cultivated lines, or natural terrain lines if naturally concealed roads do not exist (fig. 88) or if road screens are not in use. Tracks should always continue past real installations to a logical destination (fig. 89).

62. Concealment in Movement

Completely concealed routes are rarely found. Even the comparatively small amount of timber that is cut to clear a roadway reveals the road to the aerial observer. However, partially concealed roads are better than exposed roads and are to be used when possible. Gaps in overhead cover may be concealed by erecting overhead screens of natural or artificial material or a combination of both (fig. 90). All routes should be marked in advance and guards posted to insure that no deviation from the marked routes occurs (fig. 91).

63. Dispersion of Vehicles

Dispersion serves two purposes; it aids in concealment of the vehicles and it reduces the possibility of damage to the vehicles from bombing or strafing (fig. 92). Distance between vehicles depends on the terrain and the tactical situation.

64. Shine

Shine may nullify even the best site or track discipline. Shine can exist when there is natural or artificial light in the sky. Shine may come from any part of a vehicle, and can be revealed through any of

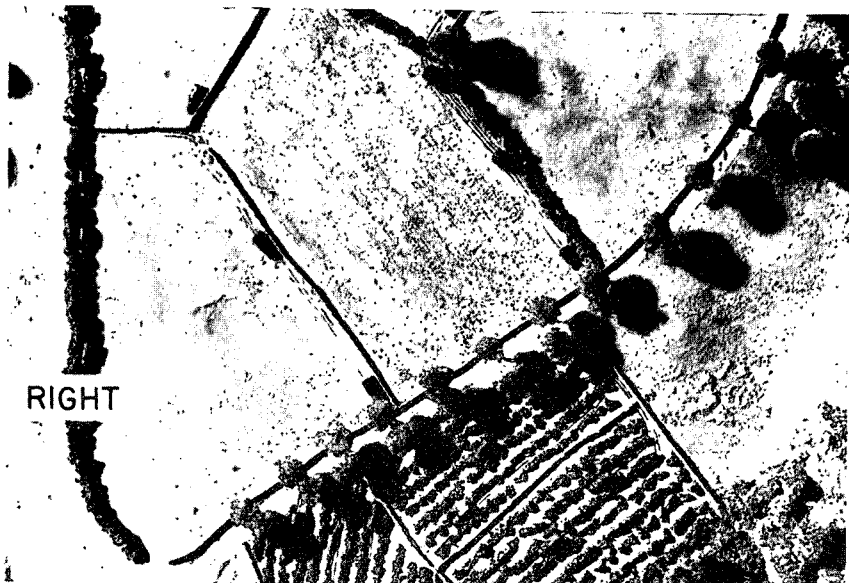

①



②

Figure 88. Blending tracks with terrain.

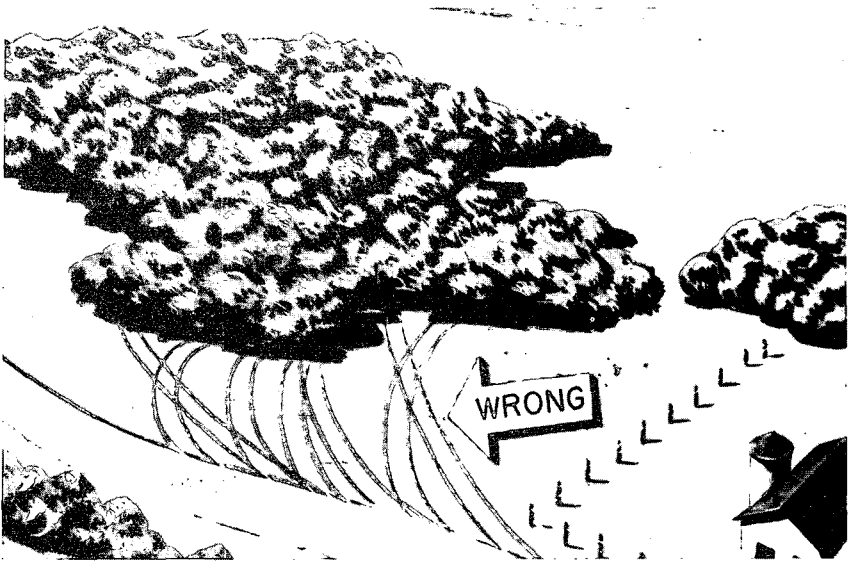

1

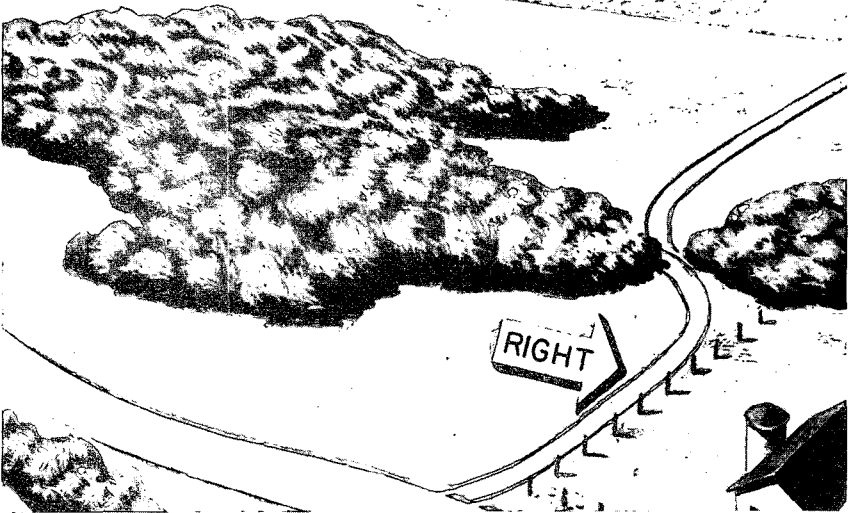

2

Figure 89. Tracks ending at logical destination.

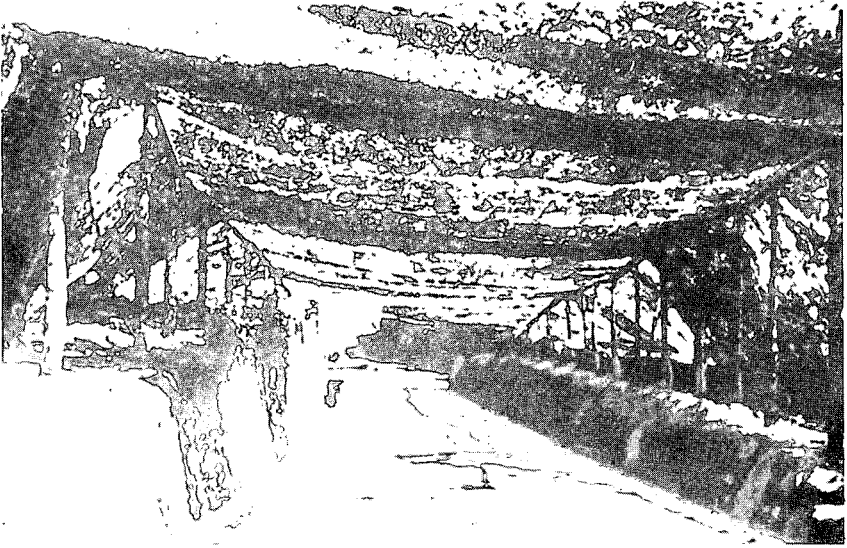

Figure 90. Screen concealing road.

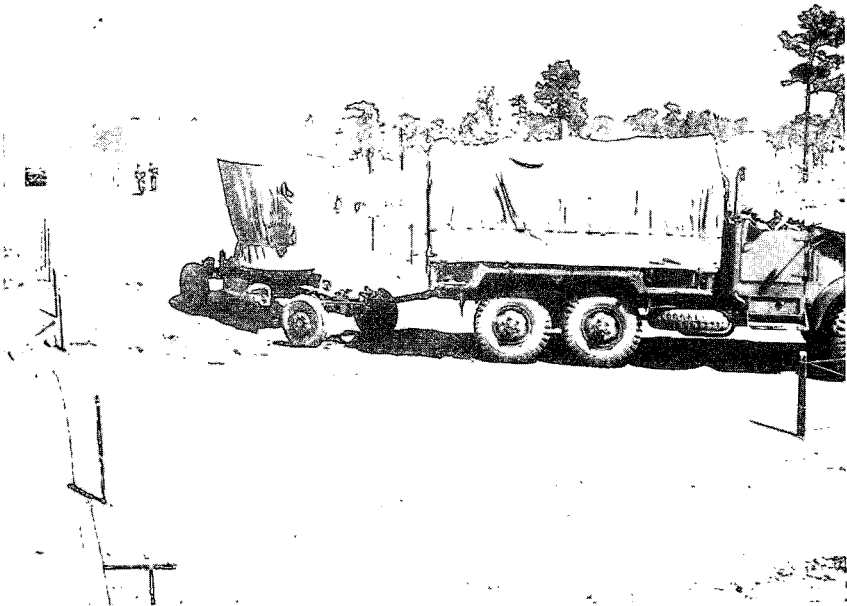
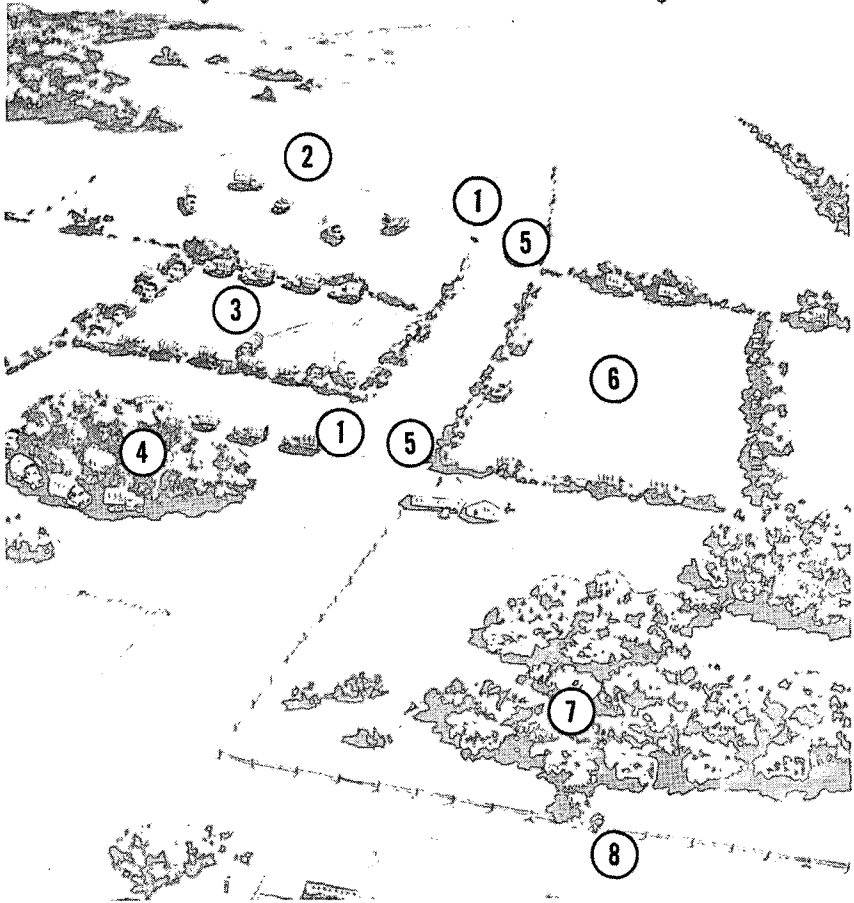

Figure 91. Marked route.

WRONG



RIGHT



- | | | | |
|---|--|---|--|
| 1 | Corners cut short | 5 | Existing tracks used for access |
| 2 | Tracks and parked vehicles contrast with terrain pattern | 6 | Correct dispersion. Good use of lines in terrain pattern |
| 3 | Insufficient dispersion and exposed tracks of three vehicles | 7 | Correct dispersion and good use of overhead cover |
| 4 | Insufficient dispersion; newly made tracks point to position | 8 | Inconspicuous tracks to cultivated field |

Figure 92. Use of terrain and dispersion.

the numerous gaps which exist in overhead concealment. Shine is concealed by using natural or artificial materials (fig. 93).

65. Shadow

Use of shadow is the primary step in the concealment of vehicles. The concealing shadows cast by objects such as buildings, trees, and rock formations can be used to good advantage (fig. 94). However, vehicles must be moved during the daylight hours to keep them within the concealing shadows. The overall outline and the shad-



Figure 93. Shine concealed by natural materials.

owed areas, such as underneath fenders and the open back of the cargo space, are to be concealed. The shadow cast by the vehicle itself is thus eliminated because this shadow reveals and identifies the vehicle (fig. 95).

66. Site Selection

Selecting an advantageous site in the terrain pattern enables vehicles to occupy an area without altering the appearance of the terrain. Vehicles are parked under natural cover wherever it is available (fig. 96). In an area of inadequate cover, vehicles are

parked so that the shape of the vehicle with the aid of a garnished net appears to be a natural part of the terrain (fig. 97). Drivers of vehicles must learn how different types of terrain appear from the air, before they can properly site their vehicles. The main types of terrain consist of areas which are wooded, agricultural, urban, or desert and barren. Vehicles are sited to take advantage of different patterns found in these areas.

67. Wooded Terrain

Wooded terrain because of its irregular pattern provides excellent concealment (fig. 98) for a vehicle and its tracks. To preserve the natural appearance of wooded terrain, vehicles must be dispersed and parked at varying angles and at unequal distances.

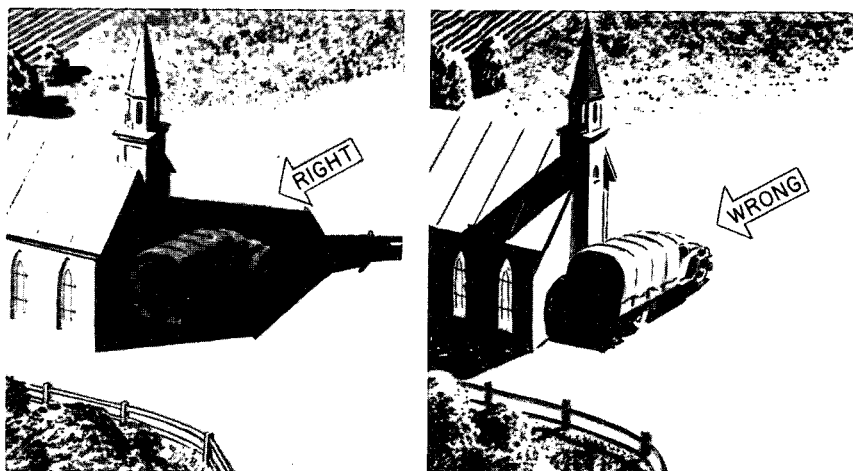

Figure 94. Use of shadow.

can be pattern painted, partially covered by dark canvas, or completely covered with small trees or branches (fig. 99).

68. Agricultural Terrain

The dominant characteristic of an agricultural pattern is a network of lines: fencelines, hedge lines, cultivation lines. A high degree of concealment is obtained if vehicles are dispersed parallel to terrain lines so that the lines remain more prominent than the vehicles (fig. 88).

69. Urban Terrain

The pattern of cities, towns and villages affords many opportunities for concealment (fig. 100). Urban areas usually provide large shadow areas and some overhead cover. The wall lines of buildings

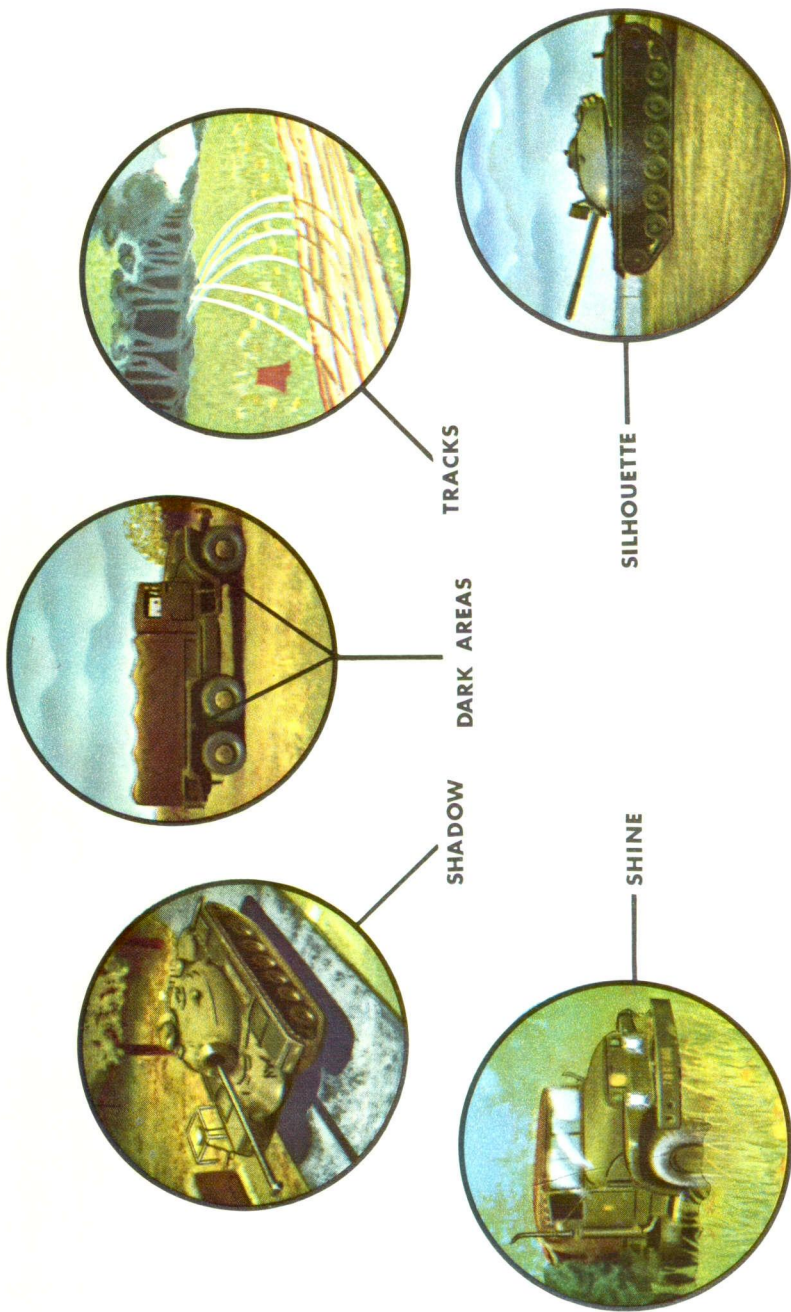

Figure 95. Revealing features of vehicles.

can be used in the same way as hedge lines were used in agricultural pattern. Screens can be attached to roofs or eaves of buildings to aid in the concealment of vehicles.

70. Desert or Barren Terrain

When time and spoil permit, every effort must be made to dig in important vehicles. Digging-in aids concealment and reduces the possibility of damage from bomb and shell fragments (fig. 101).



Figure 96. Vehicle under natural cover.

71. Snow and Ice Area

a. Snow-covered terrain is seldom all white. The snow pattern normally is broken up by dark areas such as woods, scrub growth, and shadowed areas made by irregularities in the ground. Pattern painting of vehicles in partial snow areas aids greatly in siting (fig. 102). In all snow terrain the vehicle may be painted all white or covered with whitewash (fig. 103). White osnaburg may be used to drape over the vehicle to facilitate siting.

b. Tracks are a major obstacle to good siting in snow and ice areas. In even light snow, tracks make strong shadow lines. Sharp



Figure 97. Vehicle concealed with aid of net.

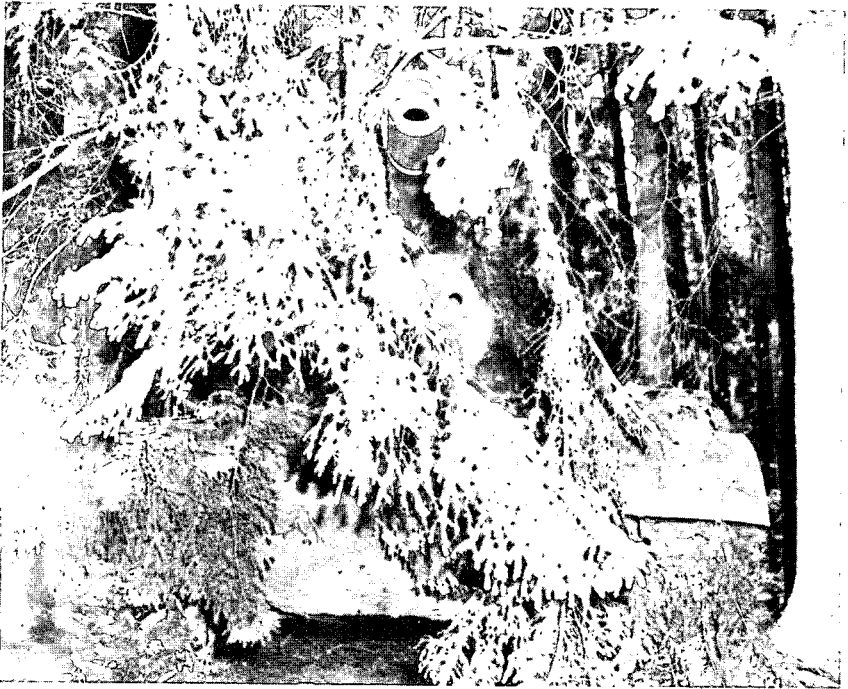
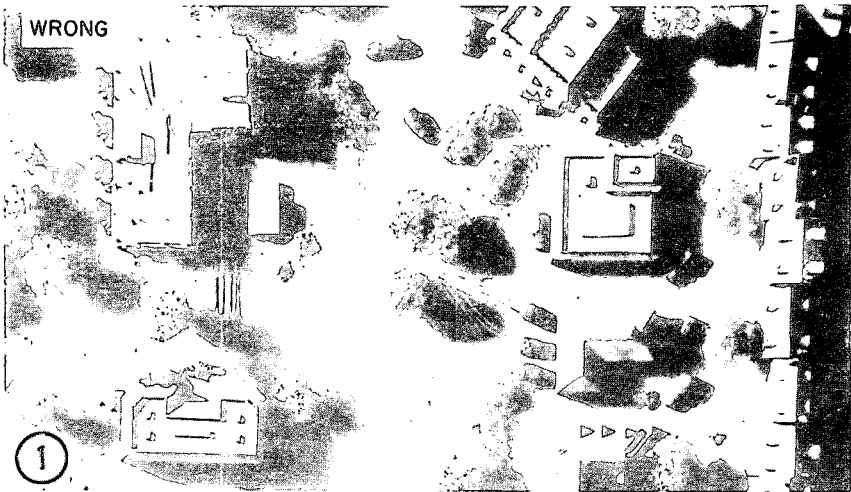

Figure 98. Tank concealed in wooded area.



Figure 99. Truck concealed by use of canvas and branches.

turns by vehicles should be avoided because ridges of snow cast heavy shadows. Whenever possible, vehicles should follow shadow casting terrain lines, staying on the side where shadows are constant throughout the day. It is important that all vehicles keep to the same tracks. Short lengths of tracks which are not too deep may be trampled down with snowshoes.



1 Wrong

Figure 100. Vehicles parked in urban area.



2 Right

Figure 100—Continued.

c. Dark shadows stand out clearly in snow and ice areas. Shadows are distorted or concealed by use of natural materials, by siting so vehicle shadows fall on the dark vegetation or another shadow, or by use of drape nets garnished to match the terrain.

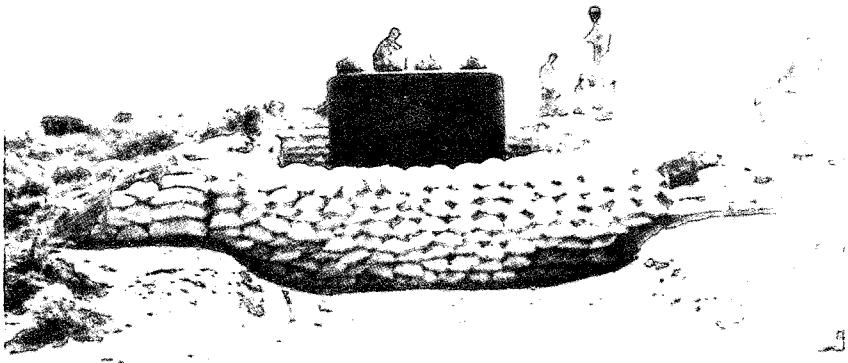

Figure 101. Camouflaging a dug-in vehicle.



Figure 102. Vehicle in partial snow area.



Figure 103. Vehicle in snow area that requires paint or whitewash.

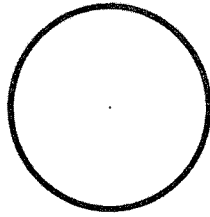

Figure 104. Aerial view of all white vehicles in snow area.

CHAPTER 9

BIVOUACS, COMMAND POSTS, AND FIELD SERVICE INSTALLATIONS

72. General

The problems of concealment of bivouacs, command posts, and field service installations are similar in the various geographic terrain areas. Each is an activity in which personnel and equipment are closely grouped in a particular area for more than a few hours. Elements of the unit are concentrated in a smaller area than usual and, except for security elements, the men are less alert than when engaged in combat. The breaches in camouflage discipline which can occur when a unit has occupied an area for some time (fig. 105) must be avoided. A thorough reconnaissance of the terrain to be occupied should be accomplished prior to occupation, taking into consideration the tactical situation and camouflage. This will eliminate confusion in moving into the area, prevent any unnecessary camouflage construction, and insure an orderly occupation of the area.

73. Development of the Bivouac

There are four critical stages in the development of a bivouac. Listed in the order in which they occur, they are planning stage, occupation stage, maintenance stage, and evacuation stage.

74. Planning Stage

a. General. Frequent bivouacs are characteristic of mobile warfare. In such warfare, there is seldom time or facilities to erect elaborate constructions for concealment. Bivouacs are usually hastily occupied and quickly evacuated. Camouflage measures are hasty in nature, and dependent upon local natural materials. The most important elements in the planning stage of a bivouac are the missions of the advance party and the quartering party.

b. Advance Party. The advance party should consist of a representative from the headquarters that ordered the move, a representative from each subordinate unit and a camouflage expert. This party should make a thorough reconnaissance of the area proposed and then divide the area into subordinate unit areas. The quartering party, from each subordinate, then makes its reconnaissance of

the assigned area, taking into consideration both the tactical and camouflage capability.

c. Quarters Party. Before going into the area the quartering party should become as familiar as possible with the terrain and the ground pattern, through a careful study of maps and aerial photographs, and should be fully acquainted with both the tactical plan and the camouflage requirements. They should designate dispersal points and concealment areas for the subordinate units, select cutting areas for natural materials, tape motor park and roadways, and post

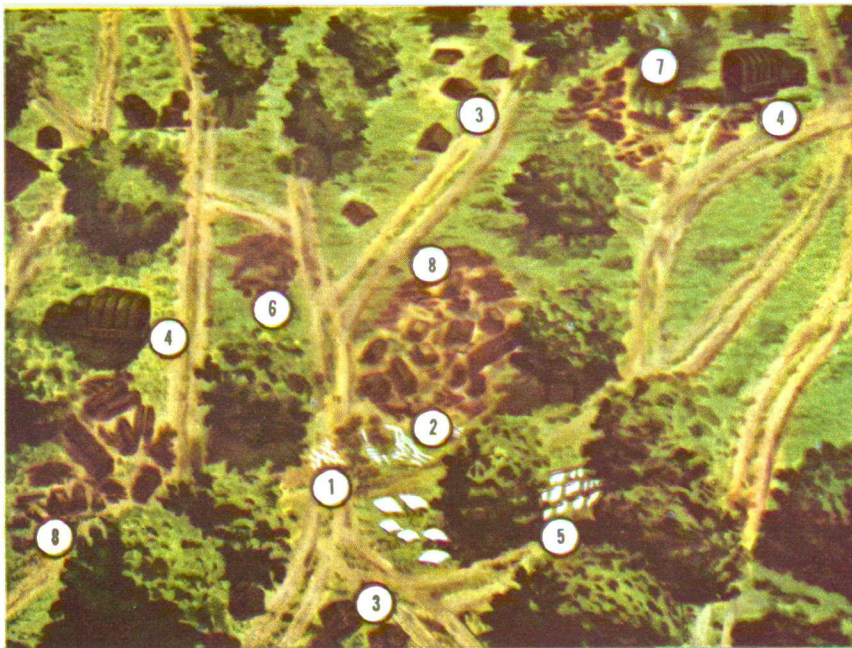

- 1 Uncontrolled tracks
- 2 Exposed spool
- 3 Tents in open
- 4 Unconcealed vehicles

- 5 Laundry drying in open
- 6 Exposed litter
- 7 Smoke
- 8 Exposed supplies

Figure 105. Breaches in camouflage discipline.

traffic regulations and guides. The critical elements which the quartering party must keep in mind are—

- (1) *Mission of the unit.* The tactical plan and its demands, which normally includes the concealment of the bivouac, must be satisfied as completely as possible.
- (2) *Access routes.* Effectiveness of concealment depends greatly on a well-prepared and well-maintained track plan.
- (3) *Existing concealment qualities of the area.*
- (4) *Area in relation to the size of unit.* The area should be large enough to afford natural concealment through dis-

persion, taking advantage of terrain features, and the use of natural materials.

- (5) *Concealment of the all-round defense element of the position.*
Even though other elements of a bivouac are well concealed, a conspicuous all-round defense may betray the position.

d. Siting. Proper siting solves to a large degree the concealment problem. An ideal bivouac area, for example, is a large wooded area containing many existing routes of approach (fig. 106). However, such an ideal place is seldom found. Military units should be sited where possible to take advantage of terrain features such as shadow, terrain lines, rocky areas, villages, farms, and defilades. The individual must be ready to fit himself and his equipment inconspicuously into any type of terrain.



Figure 106. Bivouac area containing existing routes of approach.

75. Occupation Stage

a. General. The occupation stage is limited to the period during which the unit is moving into the bivouac area. A carefully controlled traffic plan is mandatory during this stage of the bivouac. This is the most critical stage in the bivouac. Guides posted at route junctions should be fully informed as to the camouflage plan. One of their duties is to enforce camouflage discipline. Vehicle turn-ins must be wired to prevent widening of corners. Foot troops must follow wired paths through the areas (fig. 107).



Figure 107. Wired path.

b. Dispersion. Dispersion should be automatic and should provide for a minimum of 50 square yards per man and no less than 20 yards between tents (figs. 108 and 109). Vehicles will seldom be less than 50 yards apart in ordinary terrain or less than 100 yards in desert areas. The kitchen area should be carefully selected to provide for the various parts of the kitchen. The three main congested areas that must be dispersed are the food dispensing area, mess kit washing area, and eating area.

c. Immediate Camouflage Measures. Camouflage is not something applied as an afterthought to other activities. Camouflage measures must be immediate and continuous. Vehicles and equipment should

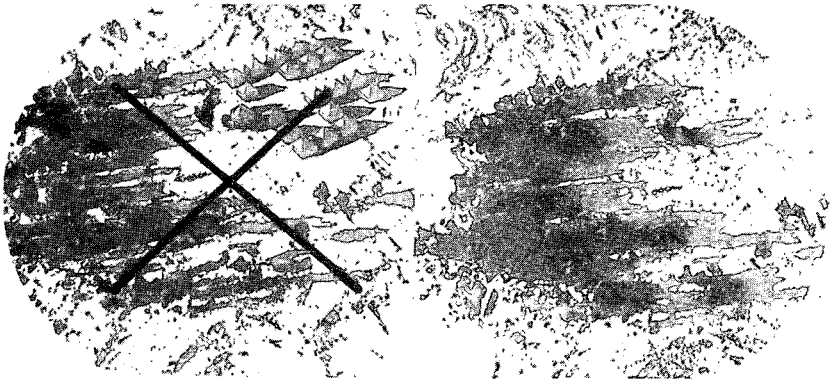

Figure 108. Dispersal of tents.

be concealed as soon as they are properly sited (fig. 110). Immediate steps should be taken to obliterate vehicle and equipment tracks. This may be accomplished by using leaves, brush, or other natural materials to cover up tracks (fig. 111). In sandy areas a drag or rake can be used to eliminate tracks.



Figure 109. Camouflaged tent.



Figure 110. Vehicles properly sited and camouflaged.



Figure 111. Covering tracks.

d. Tracks. When it is impossible to stay on existing routes and paths, three courses are open to the unit.

- (1) Make new paths and tracks along existing lines (fig. 112). New tracks adjacent to and paralleling such lines are far less conspicuous than fresh tracks breaking a "clean" area.
- (2) If a new path in an open area must be made, it must be extended beyond its destination to a natural termination, such as a junction with a road. This false section must appear as well traveled as the true section. A new route must enter concealment some distance from its destination. Turn-arounds are to be avoided. Traffic-control plans which include a one-way system of travel must be strictly enforced.

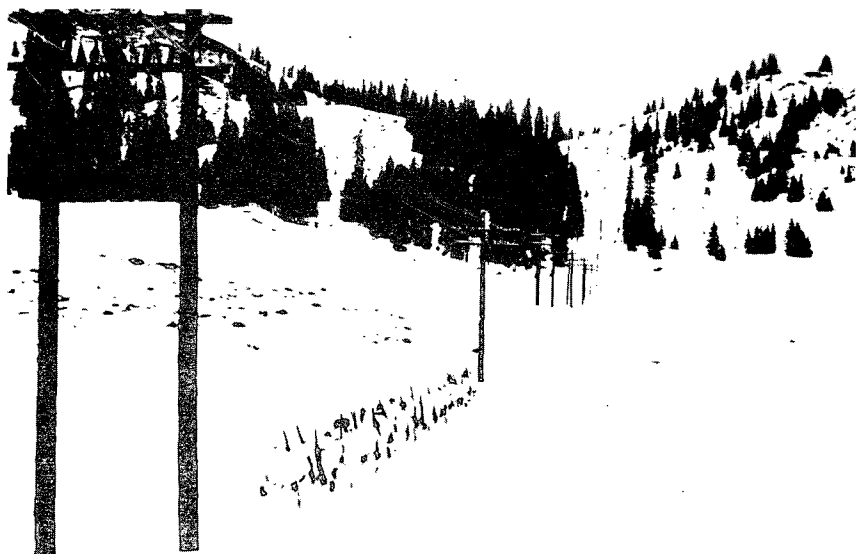

Figure 112. Troops moving to bivouac along existing communication lines.

- (3) In some cases, tree tops can be pulled and wired together to cover exposed areas. A more elaborate and difficult procedure (possible only in somewhat prolonged bivouacs) is the construction of overhead screens to conceal small sections of newly created paths and roads. This is a time-consuming operation and should be considered only as a last resort in such temporary operations as bivouacs.

76. Maintenance Stage

a. General. The maintenance stage of a bivouac commences when the unit has arrived in the area and terminates when the last element departs. If the occupation stage has been successful from a camouflage standpoint, the maintenance stage is relatively easy. Suc-

cessful maintenance involves frequent ground inspection of the bivouac area, active patrol measures for camouflage discipline, and, if possible, aerial observation and photography and the correction of defects.

b. Kitchen Areas. Critical activities of a unit in bivouac are those which call for the congregation of troops; water facilities (fig. 113)



Figure 113. Camouflage of lister bag.

and messing. Mess facilities must be centrally located in a well-concealed area. The track plan must be rigidly enforced. Mess areas should provide ample space for mess lines, wash lines, and eating. Artificial overhead cover may be necessary to conceal mess areas (fig. 114). Garbage disposal pits should be accessible, but not

too close to the mess area. The spoil from the pits must be carefully concealed (fig. 115). In the kitchen itself, if cooking stoves other than issue gasoline burners are used, the problem of smoke should be met by constructing a baffle above the stove so that the smoke is well dispersed. The baffle itself should be camouflaged and concealed from aerial view.

c. Night Discipline. Camouflage discipline at night is just as important as daylight camouflage discipline. The rigid rules for daylight must be observed because the enemy can use infrared surveil-



Figure 114. Camouflage over mess wash area.

lance equipment and aerial photography to detect any breach of night camouflage discipline. Night photographs are surprisingly revealing. Wired and taped paths (fig. 107) must be followed and black-out control must be enforced. No lights or fires are to be permitted except under adequate concealment such as inside lightproof tents, dugouts and caves. Material or articles of clothing are concealed at night to prevent reflection or shine (fig. 116) from the light of aircraft photoflares.

77. Evacuation Stage

The camouflage of a bivouac is not terminated when the unit moves out. An evacuated area can be left in such a state of disorder that aerial photographs taken by the enemy will reveal the strength of the unit which occupies it, the kind of equipment carried, and the direction in which it went. It is part of camouflage discipline to leave the area looking undisturbed because friendly advancing troops may want to use the same area. Decoy bivouacs may sometimes be used as part of the tactical plan, during occupation or after departure.



Figure 115. Covered disposal pit.

78. Geographic Areas

a. Bivouac in Open Terrain. Concealment in terrain which lacks natural overhead cover, such as open fields or the outskirts of villages, depends mainly on careful siting, dispersion and effective camouflage discipline. Shelter tents should be pitched along lines which are normal in the terrain pattern, such as fence and hedge lines, or beside folds in the ground or other shadow-casting irregularities in the ground surface. Disruptive patterns made with charcoal (fig. 117), paint, mud, or stain from vegetation may be applied to tents to help blend them with their environment. During the daytime, tents should be struck and concealed with natural materials. If time permits, equipment should be at least partially dug in and spoil

placed around it in such a manner as to minimize the shadows. Spoil lightens in color as it dries out and must be toned down with other natural materials.

b. Snow-Covered Terrain. Although camouflage in snow-covered terrain follows exactly the same principles as other camouflage, it presents several special problems. A blanket of snow often eliminates much of the ground pattern, making blending difficult. Differences in texture and color disappear or become less marked. However,



Figure 116. Covering used ration cans to prevent shine.

snow-covered terrain is rarely completely white, and by taking advantage of dark features in the landscape, a unit on the move or in bivouac may often blend itself successfully into the terrain (fig. 118).

- (1) Good route selection is usually more important than any other camouflage measures because exposed tracks are difficult to conceal. If, in selecting a route, advantage is taken of the dark features of the landscape, tracks will blend in very well (fig. 112). However, this does not mean that

exposed tracks in open terrain of this nature cannot be concealed or toned down. Tracks may be concealed by using a drag to smooth out the snow or to slope the tracks obliquely at the sides in order to minimize their shadows. When moving into a bivouac area, extreme care must be exercised to avoid leaving exposed tracks pointing toward the site to be occupied. One method of eliminating this is to continue tracks past the entrance to the bivouac area to a predetermined destination. Skis and snow shoes should not be used near the bivouac since their mark (tracks) are more sharply



Figure 117. Charcoal used for pattern painting of tents.

defined and more easily seen than foot tracks. To help avoid detection, personnel, vehicles, and materials should be restricted from open areas.

- (2) Vehicles may be pattern painted or painted a solid white, depending on the terrain. This applies to tentage and other facilities as well as vehicles (fig. 119). Bivouacs which have been well concealed in snow terrain for some length of time can be identified easily when the snow melts, unless precautions are taken. This is because the compacted snow on much-used paths melts much more slowly than virgin

snow, leaving clearly visible white lines on a dark background. When this occurs, the compacted snow must be broken up and spread out to hasten melting.

- (3) The arctic 5- or 10-man tent should be dug into the snow and the entire tent camouflaged by placing the white inner lining over the outside. Tools, rations, and other items may be concealed under the white canvas cover of the 200-pound sled.
- (4) In wooded areas, the following measures can be used. The arctic 5- or 10-man tent is dug into the snow close to bushy



Figure 118. Bivouac in snow terrain.

trees whenever possible (fig. 119). The outline of the tent is broken by placing white camouflage parkas on the tent or by pattern painting. Sometimes, in forest areas, a bough platform supported by the nearest trees can be built above the tent. This diverts the smoke coming from the stove pipe; otherwise the smoke can be easily seen from long distances, especially on extremely cold mornings. Snow shoe and ski racks should be located under bushy trees.

c. Bivouac in Desert or Barren Areas. Experience in the desert has taught much about concealment in areas where large, convenient trees are seldom found. Such areas, comparable to the desert as far as camouflage is concerned, are unplowed fields, rocky areas, grasslands, and other sparsely vegetated areas. Certain kinds of predominately flat terrain have shadows which are made by folds in the ground and which are deep enough to allow some concealment by siting (fig. 120). Proper use of drape nets will accomplish much in rendering objects inconspicuous in areas where very little or no natural materials are available. Figure 121 is a ground view of a tent situated in desert terrain. Because it is bare, except for short grass, this terrain offers few advantages for successful siting. However, in desert terrain the identity of objects is hidden by keeping each installation as low to the ground as possible, by draping so as



Figure 119. Pattern painted tent in wooded area.

to break up characteristic form, and by giving them gently sloping sides. Even in essentially barren terrain (fig. 122) excellent concealment is possible when the configuration of the ground is irregular enough to produce a strong shadow pattern. Bivouacs should be dispersed in the shadows of underbrush and among natural terrain features such as gullies and rocks. Tents are to be painted with canvas preservative to match the terrain color.

79. Camouflage of Command Posts

a. General. Command posts have functional requirements which result in the creation of characteristic signs by which they can be readily identified. Some of the signs which indicate to the enemy observer the possible presence of a command post are—

- (1) Converging communication lines—wire and road.
- (2) Concentration of vehicles.
- (3) Heavy traffic, which causes widened turn-ins.
- (4) New access routes.
- (5) Protective wire and other barriers surrounding the installation.



Figure 120. Aerial view of desert terrain; folds in the ground are used in siting tents and vehicles.

- (6) Defense weapons and emplacements around the installation.
A good example of common breaches of camouflage discipline of a CP in a rural area is shown in figure 123.

b. General Consideration. The requirements of a large command post or a company size CP (fig. 124) are essentially the same as for a bivouac: Preliminary reconnaissance and layout by quartering parties, rapid concealment of elements, and camouflage discipline, to include a well-policed track plan. One additional consideration

is that a large headquarters is likely to remain in an area for a greater length of time than a bivouacked unit. The site must be capable of being continuously occupied while offering a minimum chance of being disclosed through changes in the surroundings. It is unwise to locate a headquarters in the only large building within an extensive area of military operations. If the CP is located in a building, there should be sufficient other buildings in the neighborhood to prevent pin-pointing the target.

c. Site Layout and Camouflage Discipline. Once the command post site has been selected, the proper organization of the position will considerably simplify the maintenance of camouflage and camou-

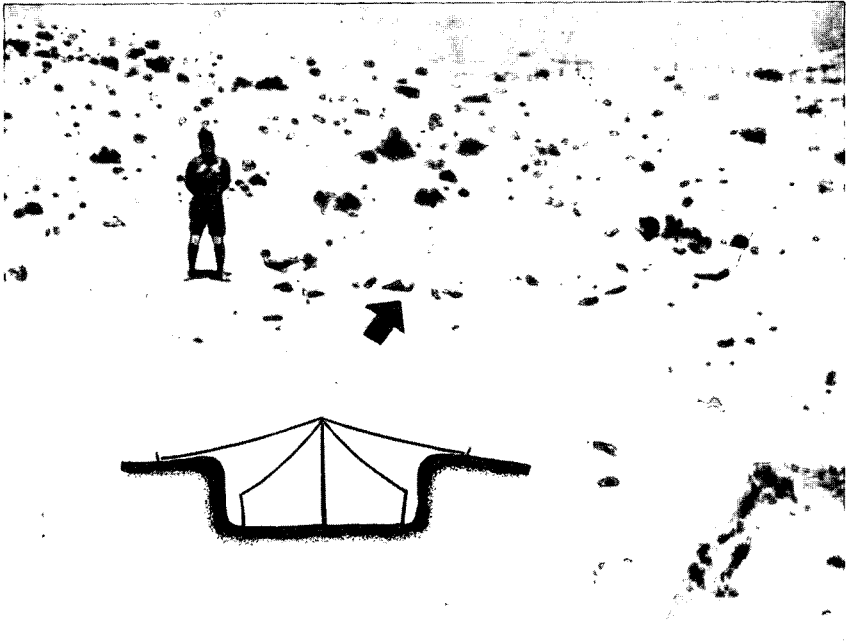
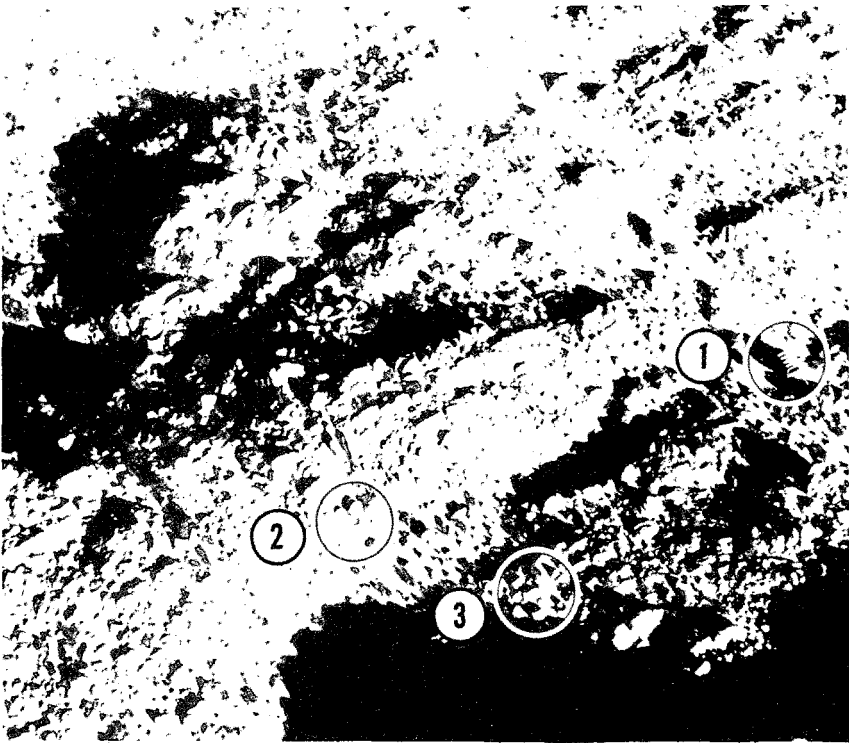

Figure 121. Tent in desert terrain.

flage discipline. The selection of a well concealed vehicle parking area several hundred yards from the CP will reduce the traffic, noises, dust, and track problems at the CP itself (fig. 125). Security weapons should be positioned to make maximum use of natural concealment; they should be located so that tracks to the positions will remain inconspicuous and all spoil may be easily concealed. Protective wire (barbed wire) must follow natural terrain lines and be as well concealed as possible. Night blackout discipline must be rigidly enforced in and around the CP area.

d. Communications. Command posts that are located to take advantage of existing roads and wire lines are more easily concealed. The terrain remains undisturbed when new routes are not required.



- 1 Truck
- 2 Supplies
- 3 Tents

Figure 122. Concealment in barren terrain.

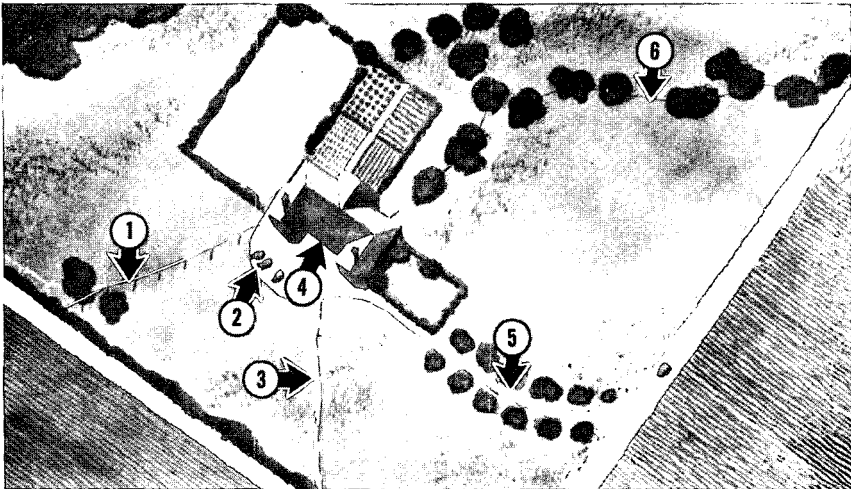

- 1 Exposed communication lines
- 4 Park vehicles in shadows
- 2 Exposed vehicles
- 5 Use existing road
- 3 New tracks
- 6 Communication lines strung in trees.

Figure 123. Rural CP showing breaches in camouflage and correct procedure to be used.



Figure 124. Company CP erected with minimum changes in surrounding area.

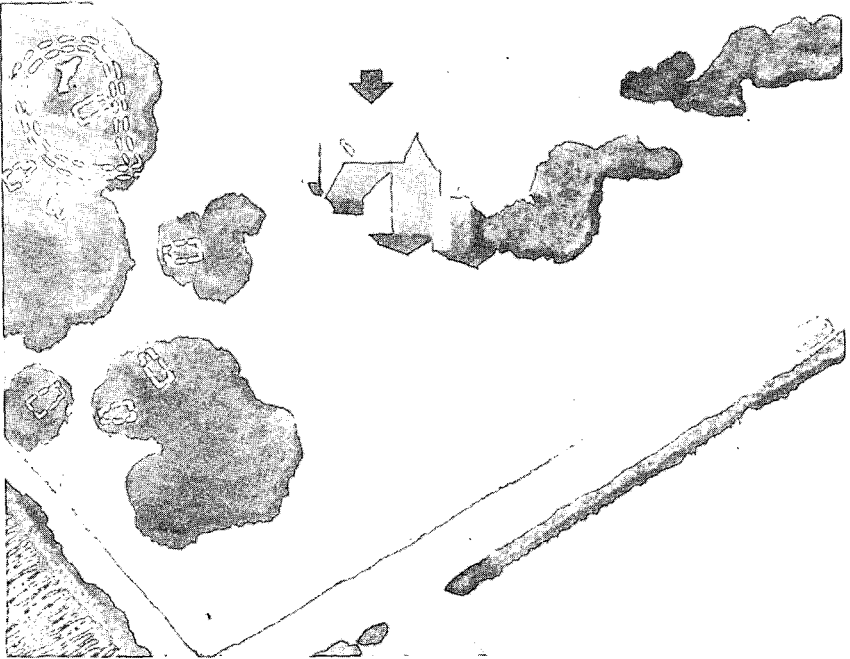
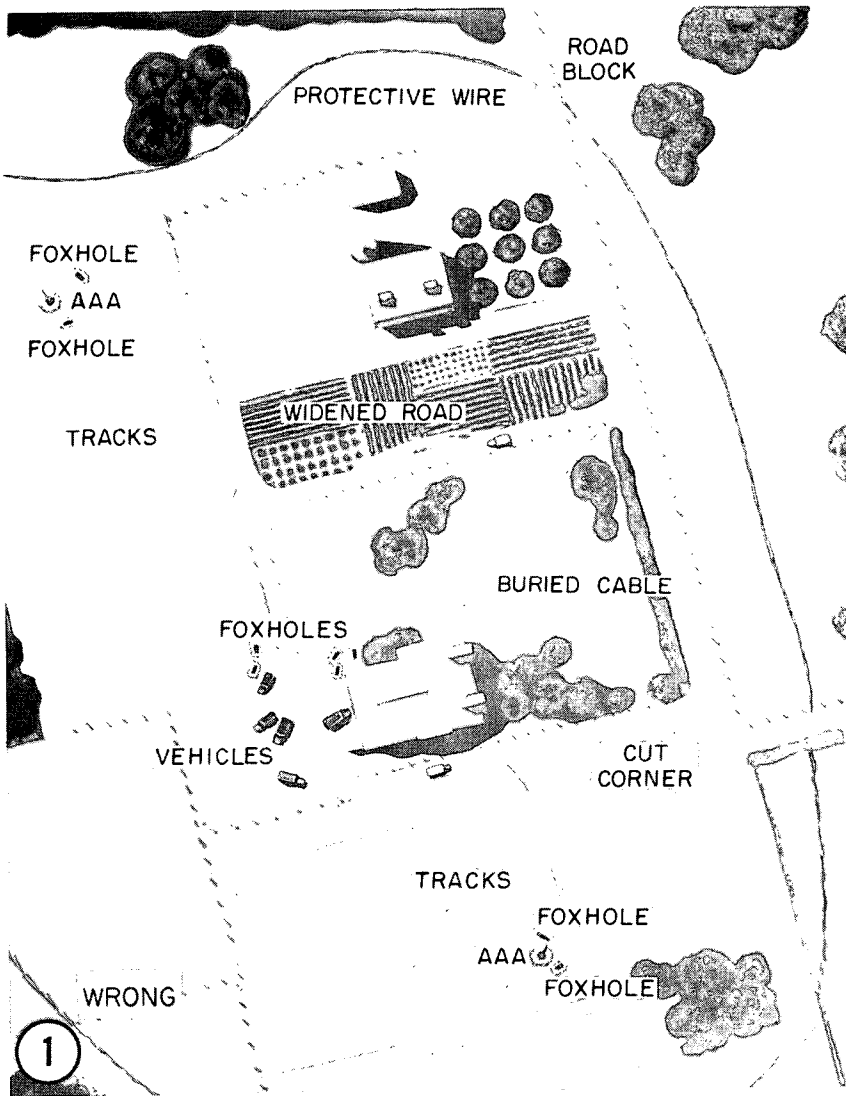
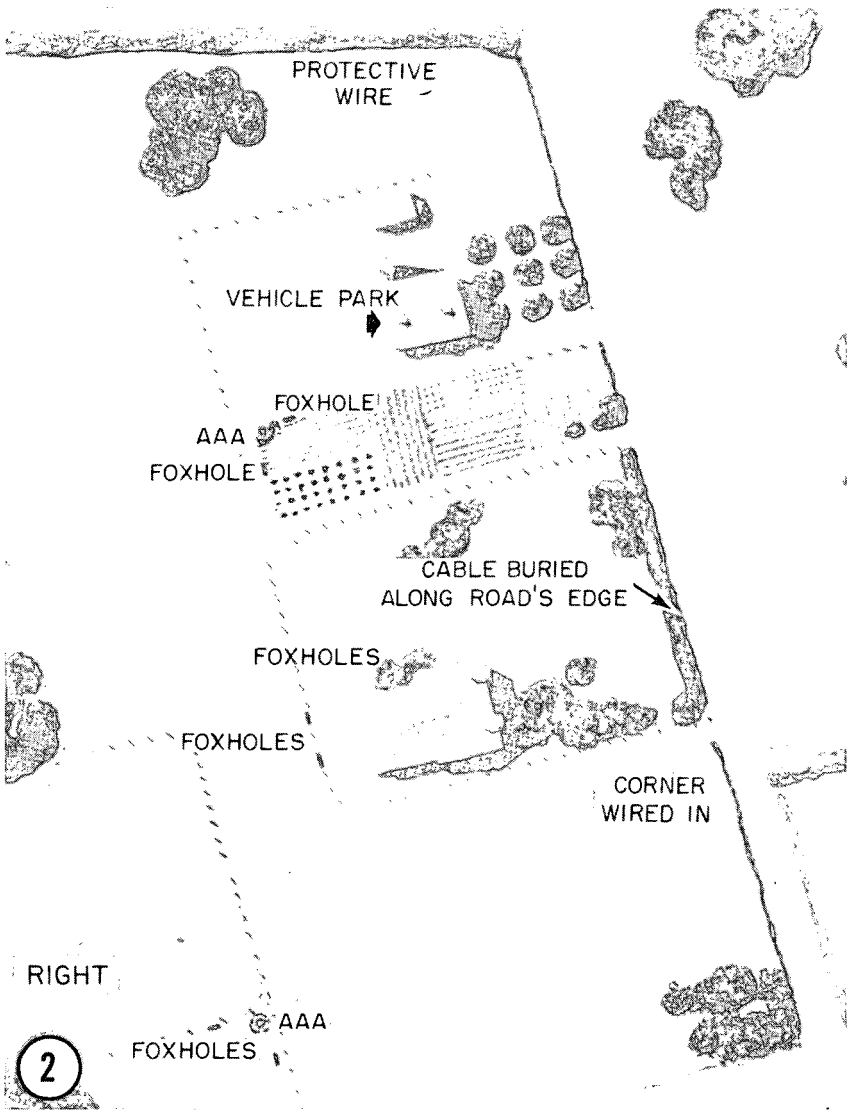

Figure 125. Possible solution for vehicle parking at CP.



1 Command post improperly organized
 Figure 126. Organization of command post.



2 Properly organized command post site
Figure 126—Continued.

As with other type installations, new communication lines are to follow existing terrain lines to the maximum possible extent (fig. 126).

e. The Command Post in Open Terrain. In open terrain where natural concealment is afforded only by small scrub growth and rocks, protection from overhead observation can be obtained by the use of drapes and flattops. The site for the command post must be chosen so that the installation may be tied into terrain features. Even in the desert, broken ground and scrub vegetation form irregular patterns with which artificial materials may be blended (fig. 127). In open terrain particularly, wide dispersion is a necessity. Routes between units must be either concealed or made by indirect courses—not by straight lines.



Figure 127. Command post in desert.

f. The Command Post in Urban Areas. The location of a headquarters in existing civilian structures presents the problems of hiding movement by day and of concealing the evidence of activity at night, when blackout conditions usually prevail. Military movement in a village or group of farm buildings is not easily discovered if kept to a minimum. Attempts to alter the appearance of buildings by disruptive painting is evidence of occupation and simply reveals a military installation. Erection of a small structure simulating a new garage or other auxiliary civilian building is unlikely to arouse

suspicion, but major changes will be closely scanned by enemy air observers. When buildings are partially destroyed and debris-littered, installations may be camouflaged with debris to blend with the rough and jagged lines of their surroundings. A few broken timbers, pieces of lath, plaster, and scattered rags will accomplish quick and effective concealment. Other debris usually available as camouflage material includes rubble, scrap metal, and wrecked vehicles.

80. Camouflage of Maintenance and Supply Points

a. General. The problem of camouflaging supply points includes all the difficulties of both bivouac and command post concealment, plus a number of particularly troublesome factors. Supply points vary in size from large concentrations of material in rear areas to small piles of supplies behind the battlelines. From a camouflage standpoint, the large area occupied by a supply point is the primary problem. Supplies of equipment of all kinds hauled to forward areas must be unloaded quickly to release the carriers for return, must be concealed quickly, and yet must be accessible for redistribution and

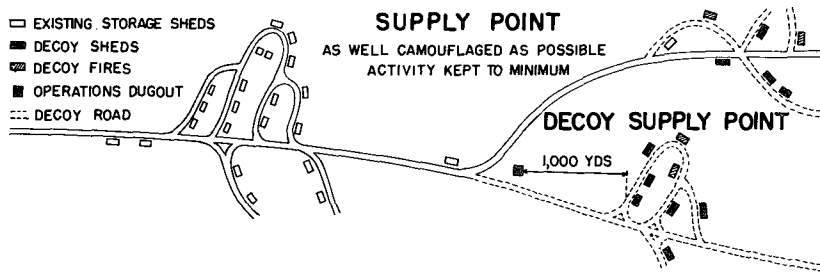

Figure 128. Drawing showing supply point and decoy supply point layout.

reloading on other carriers. Concealment must be obtained through proper siting and by use of natural materials supplemented by artificial material if necessary. For supply points which cannot be concealed, decoy supply points will often divert the enemy observer (fig. 128).

b. Planning of Supply Points. Supply points are planned to obtain dispersion and to take maximum advantage of natural concealment (fig. 129). Access roads and paths are planned to use existing overhead concealment. In some semipermanent field installations, tracks running through short open areas can be concealed by overhead nets hung between trees. Strict traffic control, including traffic guides and wired-in roads, must be used to conceal activity and movement at, to, and from the installation. Even when natural concealment is scarce, terrain features are used to utmost advantage. Terrain features are used by stockpiling supplies in the shadows or dark areas created by these features or by stockpiling supplies so that



Figure 129. Supplies under natural concealment.

the supplies resemble the terrain features (fig. 130). Camouflage discipline at supply points includes track plans that result in a minimum of changes in the appearance of the terrain, control of debris so that it does not accumulate and attract the enemy's attention, concealment and control of trucks waiting to draw supplies, and maintenance of camouflage measures. When supplies are stacked in a rectangular shape, they are made to blend with the color and textures of the background either by distributing natural materials over the tarpaulin covering the supplies or by draping supplies with garnished

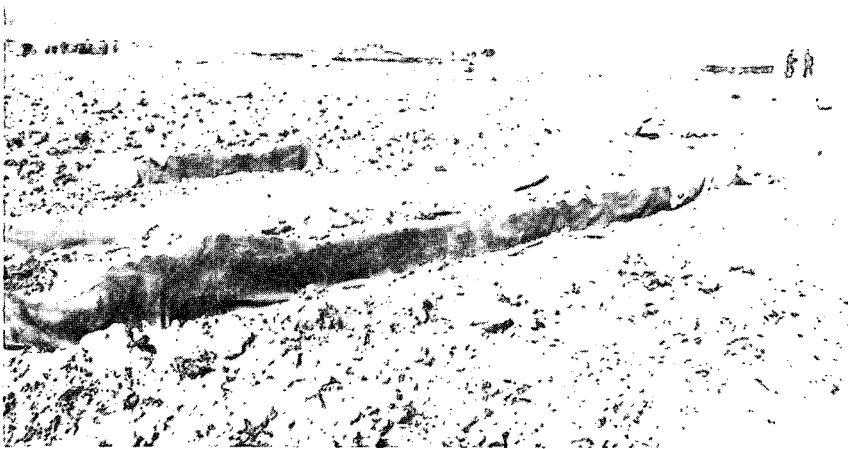

Figure 130. Supplies stacked to resemble terrain features of plowed field.

camouflage nets (fig. 131). Nets are propped above the supplies so the shape of the supplies is irregular. Supplies stacked in a pyramidal shape can be made to resemble bushes and small trees by placing natural materials on the pyramid or by draping with a garnished net. Another advantage of a pyramidal stack is that it makes a smaller shadow than other shapes. Supplies can be stacked in the shadows besides walls or stone fences, in or along ditches, trenches (fig. 132), folds in the ground, or among rock outcrops. Supplies resembling real stones in stone walls preserve an innocent appearance



Figure 131. Supplies concealed with aid of garnished net.

(fig. 133). Supplies can be stacked to simulate many other terrain features, such as native structures, haystacks, rubbish dumps, crop rows, and so on.

81. Camouflage of Water Points

a. General. There are two characteristics peculiar to water supply points which must be concealed if the position is not to be disclosed. The first of these is the one-way traffic loop which leads from the main road to the water point and back to the main road. The second is the shape of the water tanks and associated equipment.

b. Camouflage of Water Point Area. The one-way traffic loop characteristic of many water points is easily identified from the air unless proper concealment measures are taken. Selection of a position offering the best possible overhead concealment is required. Foliage too thin for perfect concealment may be supplemented by other natural materials or by artificial materials such as drapes, hammocks, and flattops. The traffic loop can be eliminated when two parallel all-weather roads flank the water point. Where possible, use should be made of all-weather roads. Gravel and dirt roads tend to become muddy and disintegrate unless the area has an excellent drainage

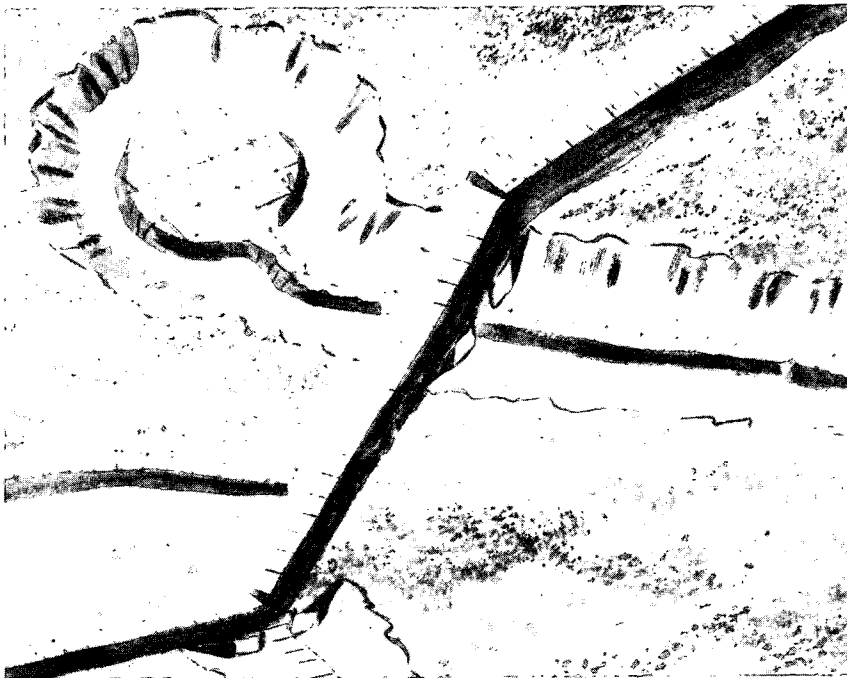

Figure 132. Using abandoned trenches and emplacement for supplies.

system. Inadequate drainage also causes the formation of pools of stagnant water resulting from spillage. These pools must be eliminated or covered with tarps or foliage, or the resulting reflections will disclose the position to an enemy aerial observer.

c. Camouflage of Water Tanks. In the camouflage of water tanks, the first consideration is the reflection of the water, which must be concealed, preferably with canvas cover or other solid woven substitutes. The characteristic shape of the tanks should also be concealed or broken up, either by foliage or artificial camouflage materials (fig. 134). Associated equipment may be covered with drape nets or hammocks, and drainage ditches or pipes should be concealed with natural materials.



Figure 133. Supplies stacked to resemble stone wall.



Figure 134. Camouflaged tanks at water point.

d. Camouflage Discipline at Water Points. Camouflage discipline at a water point includes all the usual precautions, plus a water supply schedule for using units. Lack of a schedule, or violation of the schedule usually produces a concentration of vehicles which cannot be concealed. In some instances congestion may be avoided by the provision of a concealed auxiliary parking area. Where several small water points are available, it is preferable to use them rather than a single large one, for both ease of concealment and convenience of using units. The above principles are equally applicable to water distributing points served by tank trucks.

CHAPTER 10

ANTIAIRCRAFT ARTILLERY, FIELD ARTILLERY, AND GUIDED MISSILE INSTALLATIONS

Section I. ANTIAIRCRAFT ARTILLERY AND FIELD ARTILLERY

82. General

The importance of camouflage to antiaircraft and field artillery operations cannot be overstressed. Camouflage will vary with the mission of the unit. When skillfully used in defensive or attack positions, camouflage of antiaircraft and field artillery can be an effective weapon of surprise. Concealment is greatly aided by proper site selection.

83. Site Selection

a. Information which will be of great value in the selection of battery positions can be obtained initially by studying aerial photographs of an area prior to occupation. Extensive reconnaissance may be necessary to find a position which will satisfy the need for good concealment and other requirements for successful completion of the assigned mission. The siting of the elements of a battery within the area assigned is governed by the following factors:

- (1) Need for clear field of fire. Antiaircraft artillery must have a 360° field of fire; normally field artillery requires a 60° to 65° field of fire.
- (2) Room for dispersion of guns, vehicles, and other equipment organic to the battery.
- (3) Necessity for access and supply routes.
- (4) Opportunity for the establishment of communications.
- (5) Possibilities for concealment from hostile observation.

b. Although sited for concealment and properly camouflaged the gun positions may be still obvious to the enemy observer. Wheel tracks made when siting guns, blast marks, paths made in bringing up ammunition, and carelessly strewn ammunition cases are indications of the presence of artillery (fig. 135). However, signs caused by activity around the battery position or the truck parks may not indicate the nature of the position, but they do attract closer enemy observation. To obtain a well-concealed battery of artillery, the

necessity for concealing all elements of the position is considered in the camouflage plan.

c. Every man in the unit should be taught what terrain and artillery installations look like from the air and what signs the enemy looks for (fig. 135). Units should also be trained in movement into position after dark and complete camouflage during the night. An area newly occupied by artillery at night must appear unchanged by the next morning.

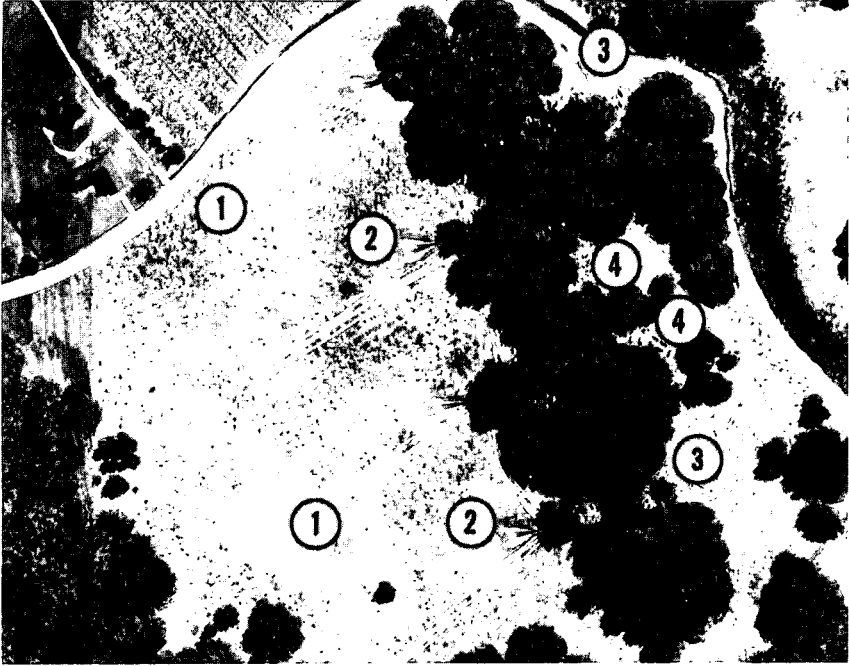

1 Tracks 2 Blast area 3 Paths 4 Ammunition cases

Figure 135. Indications of artillery.

d. An inspection is made, including aerial observation and photographs, after the artillery position is occupied to ascertain additional camouflage requirements.

84. Reconnaissance

During reconnaissance of the area before a battery moves into position, careful consideration is given to concealment of the various elements. If practical, a location is chosen for each gun which will enable the gun to be made to seem a part of an existing clump of bushes, a scrap heap, a group of small buildings, or an irregular formation in the terrain. Fire-control instruments are emplaced to take the utmost advantage of the terrain pattern within the practicable limits of parallax corrections and cable lengths. Headquarters

and headquarters units in the vicinity of firing units should be located in concealed and dispersed positions. When practicable, headquarters and headquarters units, supply points, bivouacs, vehicle parks, and similar installations are located far enough from firing units so that discovery of one segment of the battery will not reveal the other components.

85. Access Routes

It is highly desirable that a battery be located in the vicinity of good roads, with routes available to the front, flanks, and rear. This is especially important in situations where it may be necessary to make a sudden change of position. When personnel, ammunition, equipment, and other supplies are moved into a position, they must follow a prepared traffic-circulation plan. Traffic signs and guides are to be posted, and routes within the position are to be wired or

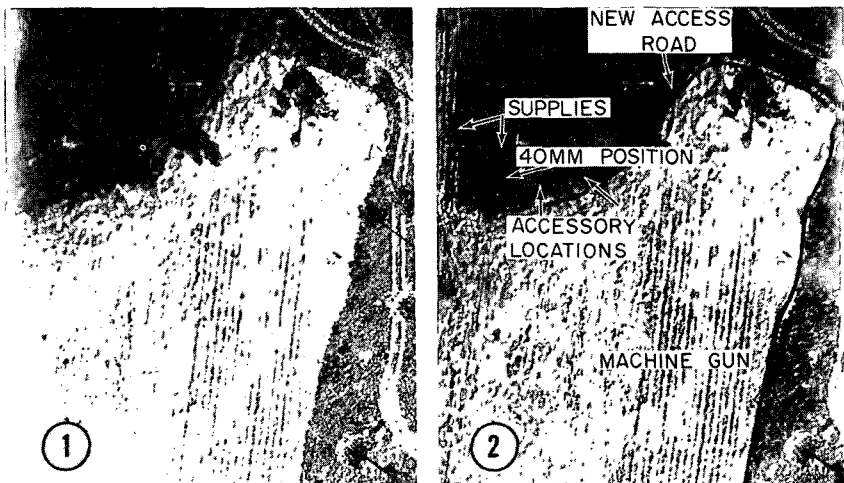

- 1 Aerial view before occupation by a 40-mm gun
- 2 Occupation plan showing access routes

Figure 136. Typical layout of a 40-mm gun position.

taped. Traffic loops are established before the position is assigned. Where access routes do not exist, the number of new access and interior routes is kept to a minimum, and they are planned to carefully conform to the surrounding terrain pattern. New tracks made will be seen from the air and will point like arrows to the position. 1, figure 136, is a view of an area before occupation by a 40-mm AA gun. 2, figure 136, is an occupation plan of the same area, showing access routes. The gun is sited at a point of dark ground cover adjacent to a furrowed field, taking advantage of the low brush which absorbs the dark shadows of the position. A new access route leaves an existing road and follows the edge of the field, where it is un-

noticed. The machinegun position is sited on one side of the field, and its access path follows the field boundary to the access route for the 40-mm emplacement.

86. Blending With the Terrain

Every type of terrain and every area within it has an individual or distinctive pattern when seen from the air. These individual patterns are the product of variations in color, surface texture, shadows, and ground formations. The aim of blending is to fit the position into an area with the least possible change in the normal appearance of the area. The first step in blending an installation with the terrain is to study the features of the pattern and to decide which can aid and which will hinder concealment. Camouflage methods used to blend the shape, shadow, and texture of an object with its surroundings vary in different types of terrain.

87. Blending Antiaircraft Artillery With the Terrain

a. Open Terrain. From the air, barren terrain has a mottled pattern, the product of scattered scrub growth, rock outcrops, and irregular ground formations. This mottled pattern is able to absorb the pattern of guns and auxiliary units of a battery. Choosing a good position in this kind of terrain is largely a matter of choosing access routes which blend with the terrain pattern. In 1, figure 137, the tracks running from the highway to the upper left are incorrectly blended with the terrain pattern and are easy to see from the air, cutting across the lines of numerous small drainage channels. In the same photograph, the tracks indicated by an arrow follow the ridge above the highway and fade almost completely into the terrain pattern. 2, figure 137, suggests a plan for an AAA position. All elements are located so that they could be connected by a single line of new tracks following the natural lines or breaks in terrain texture. Against this mottled pattern, both battery and tracks would be hard to see. To accomplish their missions, most elements of a battery must have an uninterrupted field of view, and for this reason open terrain has many advantages. However, since the concealment in open terrain is hard to achieve from the ground, extra care must be taken to locate even the smallest changes in ground texture and then have the guns and equipment placed on a boundary line between these changes (fig. 138).

b. Agricultural Terrain. Agricultural terrain usually offers excellent opportunities for concealment of new tracks and paths. Such terrain almost always possesses a closely knit system of roads, which provide good access. Figure 139 shows a farm area with a layout of a 90-mm AA battery. Full advantage is to be taken of natural lines and breaks in texture in the terrain pattern for gun positions,



1 Tracks correctly and incorrectly blended with terrain features

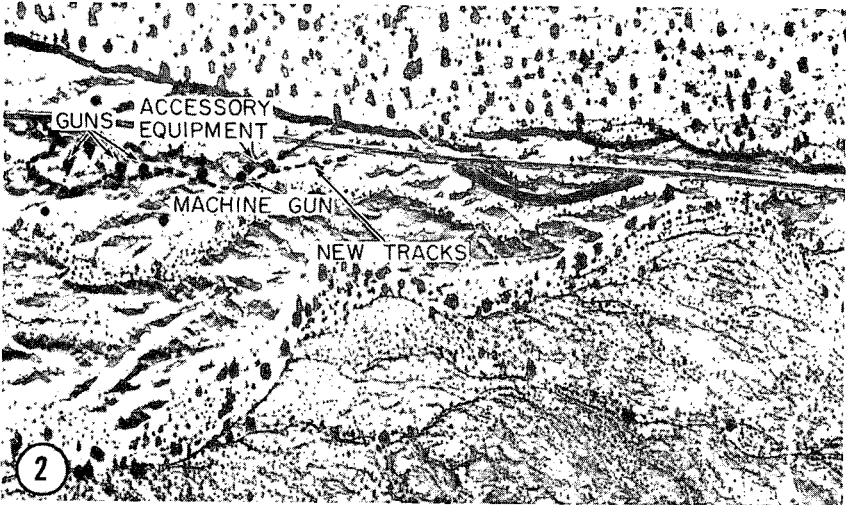

2 Suggested layout of AAA Battery

Figure 137. AAA battery in open terrain.

auxiliary equipment, cable lines, and access routes. Powerplants are to be concealed under existing natural overhead cover. Several alternate layouts can be arranged in this area with equal effectiveness. In figure 140 no attempt has been made to blend the position with the terrain pattern. The arrangement of guns is unrelated to the surroundings and the position becomes a prominent landmark. 1, figure 141, shows a different plan in the same type of terrain but which provides an equally good field of fire but with a high degree of concealment. 2, figure 141, is a closeup of two guns of the battery as

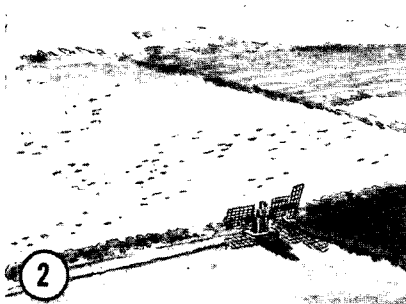
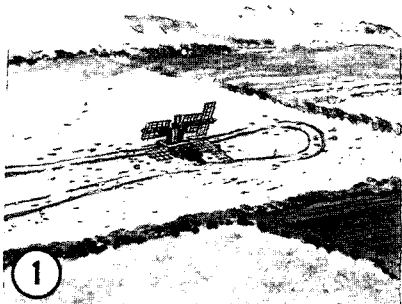

- 1 An SCR 268 tracks point to position
- 2 Unit is less conspicuous

Figure 138. An SCR 268 in open terrain.

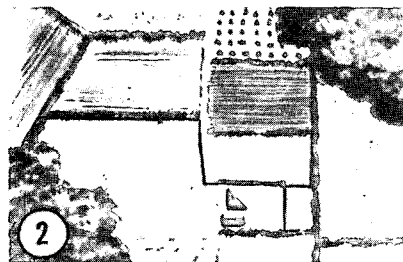
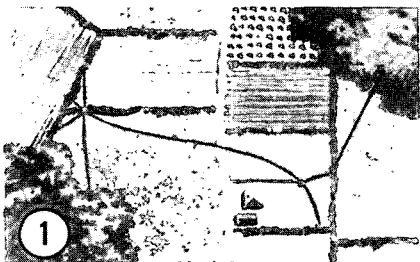

- 1 Incorrectly laid cable line
- 2 Cables laid correctly following natural terrain lines

Figure 139. Battery layout.



Figure 140. Conspicuous battery layout.

seen by a plane approaching at a low altitude, from the left of the view in 1, figure 141.

c. *Urban Areas.* AAA positions in urban areas must be made inconspicuous. The pattern areas are usually so full of variety that little difficulty is experienced in blending battery layouts into them



1 High altitude view

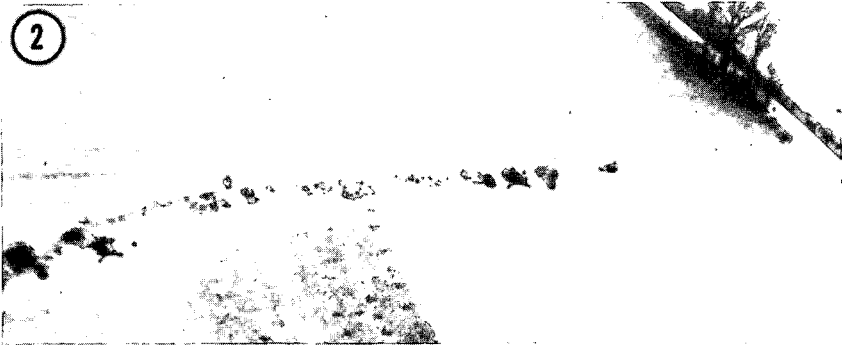

2 Low altitude view

Figure 141. Battery partially concealed along natural terrain lines.

(2, fig. 142). However, extensive reconnaissance is sometimes required to find sites that provide suitable fields of fire as well as adequate concealment.

d. *Industrial Areas.* Key industrial areas, harbor and dock facilities, and railroad centers are usually protected by AAA batteries.

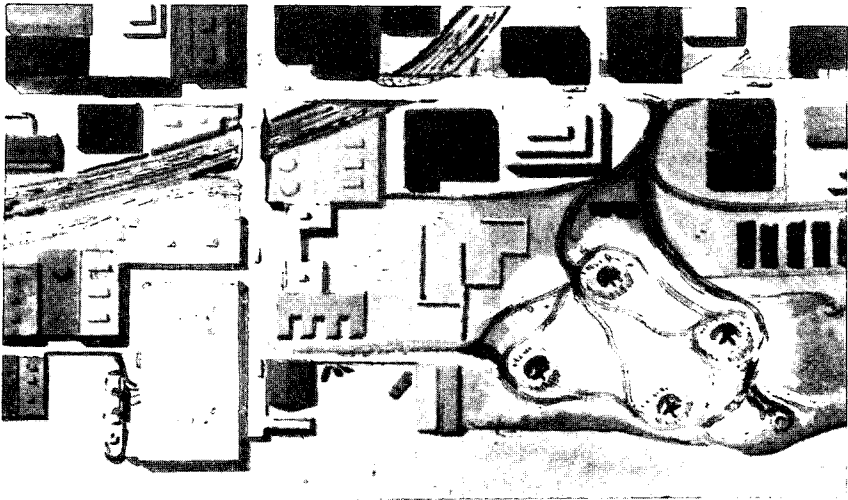

①

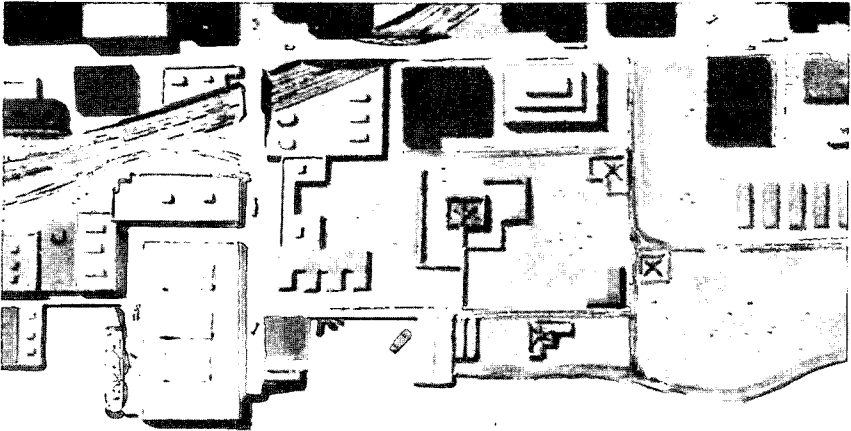

②

- 1 Conspicuous circular 90-mm gun emplacements
- 2 Inconspicuous rectangular 90-mm gun emplacements

Figure 142. Typical layout of 90-mm gun emplacement in an urban area.

Often important industrial objectives are well camouflaged and precautions must be taken to prevent an AAA installation from betraying the area it protects. In situations of this kind, the pattern of massed buildings of various sizes and the network of communication lines offer a confusion of geometric shapes into which the elements of an AAA installation are usually easily blended (fig. 143).

e. Ruins. AAA elements laid out among ruins and debris must blend with a cluttered background (fig. 144). The lines of a wrecked

building are rough and jagged. To create an irregular outline which matches them, sandbags are distributed haphazardly on and around revetments. Scraps of timber, metal, and other debris are scattered irregularly to break up the straight lines of guns, auxiliary equipment, and their shadows when seen from the air.

f. *Snow Terrain.* From a concealment point of view, snow usually obliterates many of the most useful features of the terrain pattern. It is important, therefore, to use those features which remain, such as brush, clumps of trees, streams, roads, irregular ground formations, and the edges of snowdrifts, especially where the latter cast strong shadows (fig. 145). Fence lines and other normal terrain lines

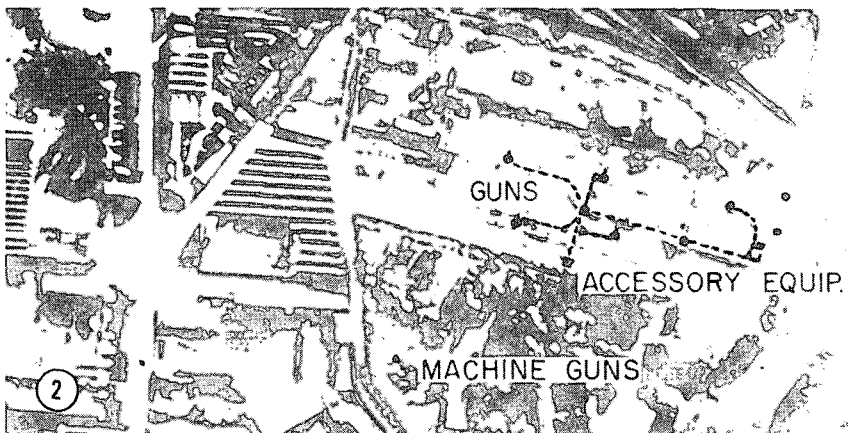
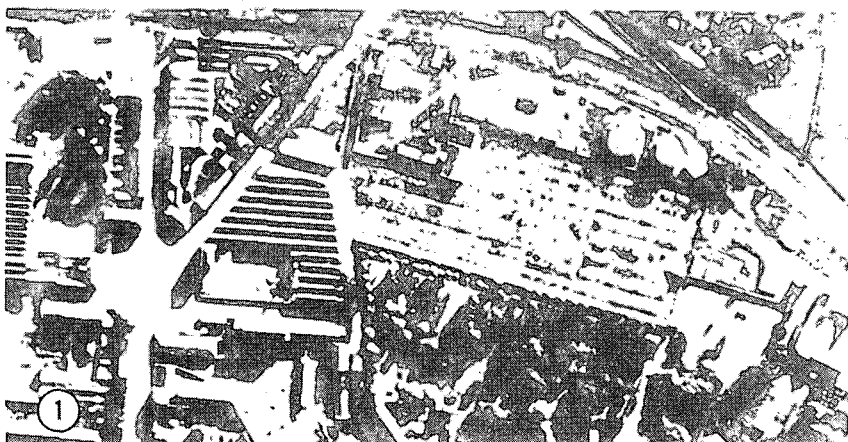

- 1 Aerial view of industrial area
- 2 Suggested layout of 90-mm battery

Figure 143. Layout of battery in an industrial area.



- 1 Incorrectly placed battery
- 2 Suggested layout of battery

Figure 144. Battery in ruined areas.

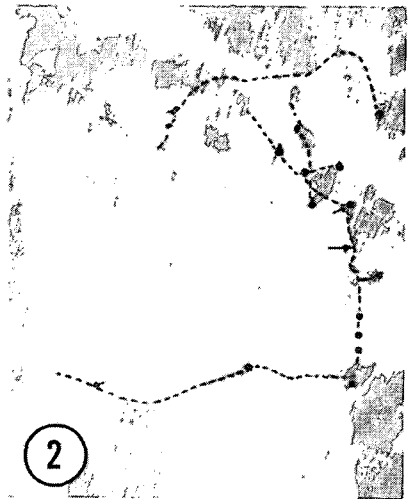

- 1 Aerial view of snow terrain
- 2 Suggested layout for battery unit

Figure 145. Layout in a snow area.

are followed for access routes. Wheel tracks are to be leveled out to reduce shadows within them. Snow can be shoveled over blast marks resulting from ground fire.

88. Blending Field Artillery With the Terrain

a. Wooded Areas. Good concealment can usually be found among large trees. However, batteries must be located so that the need for slashings to obtain field of fire is avoided (fig. 146). If it becomes necessary to cut down trees to prepare a position, small standing trees can be bent and wired together to mask the exposed area (fig.



Figure 146. Gun position in wooded area.

147). Terrain with scattered trees and bushes is often more desirable than thick woods, because of better field of fire (1, fig. 148). A dispersed battery can be concealed in this type of terrain by using camouflage net sets to supplement existing natural concealment (2, fig. 148).

b. Agricultural Areas. It is difficult to conceal battery installations completely from aerial observation in open country, without the use of artificial materials. 1, figure 149, illustrates dug-in artillery emplacement in open terrain with net set opened to permit firing. 2, figure 149, shows the same emplacement with net closed after com-

pletion of firing mission. Partial concealment may be obtained along hedge lines and brush patches and in overgrown gullies and folds in the ground. Figure 150 is an aerial photo of an artillery battery preparing positions in a clearing. Four pits have been dug and nets will be used to supplement natural materials to complete the camouflage. Existing roads give quick access to all elements of the battery.

c. Urban Areas. Positions in towns or near groups of farm buildings offer good possibilities for concealment. Existing roads or streets conceal tracks and debris and ruins furnish camouflage materials (fig. 151).

d. Desert and Snow Areas. Terrain features, such as cliffs, wind-eroded gullies, and mottled areas of sparse vegetation or rocks, are



Figure 147. Small trees bent to conceal exposed area.

used for partial concealment. Nets with artificial garnishing aid in completing camouflage (figs. 152 and 153).

89. Use of Natural Materials

For information on natural materials, see paragraphs 24 and 25.

90. Use of Artificial Materials

Artificial camouflage materials most useful to AAA and artillery units are twine nets and wire netting. Wire netting, although heavier and bulkier, holds its form better, is more durable, and is invaluable in concealing positions of a permanent nature. A clear field of fire for guns requires camouflage nets which can be opened or removed instantly. Both twine nets and wire netting can be gar-



1 105-mm battery (weapons should be dispersed)

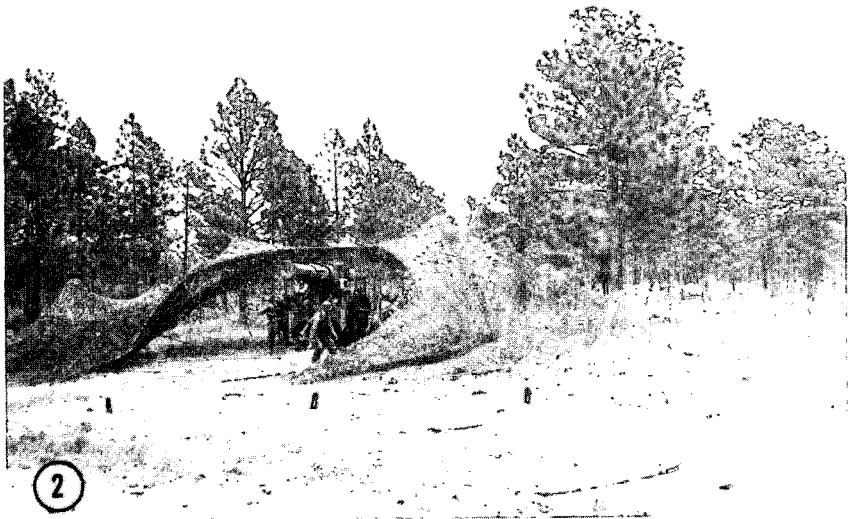

2 280-mm gun position, with net being partially opened for firing
Figure 148. Gun positions in area with scattered vegetation.

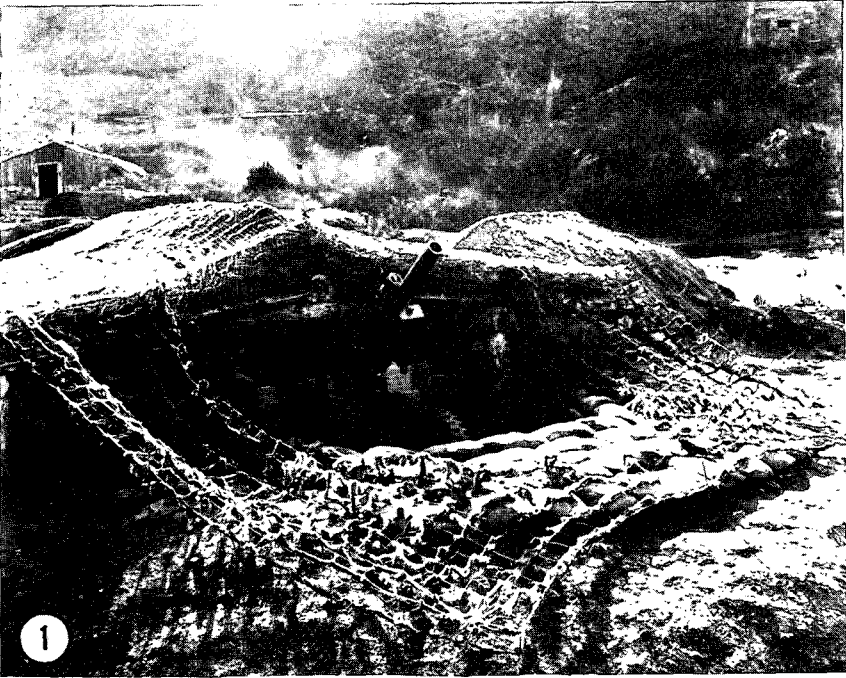

1 Net open for firing

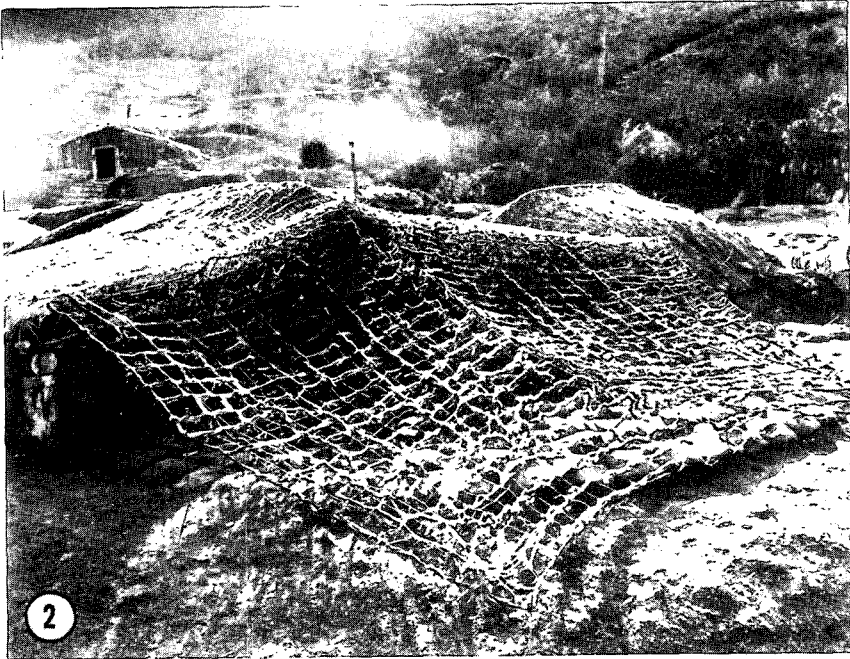

2 Net closed after completion of firing mission
Figure 149. Dug-in artillery in open terrain.

nished with either cloth strips or natural materials or with a combination of both.

91. Observation and Command Posts

Observation posts should not be placed in the most salient positions because the enemy will examine these areas minutely. The camouflage problem of observers is similar to that of frontline infantry, and all personal concealment measures should be taken. Command posts and fire-direction centers require special care in concealment and in camouflage discipline because of their importance to operations and the large amount of traffic to them. Drape and flattop nets may

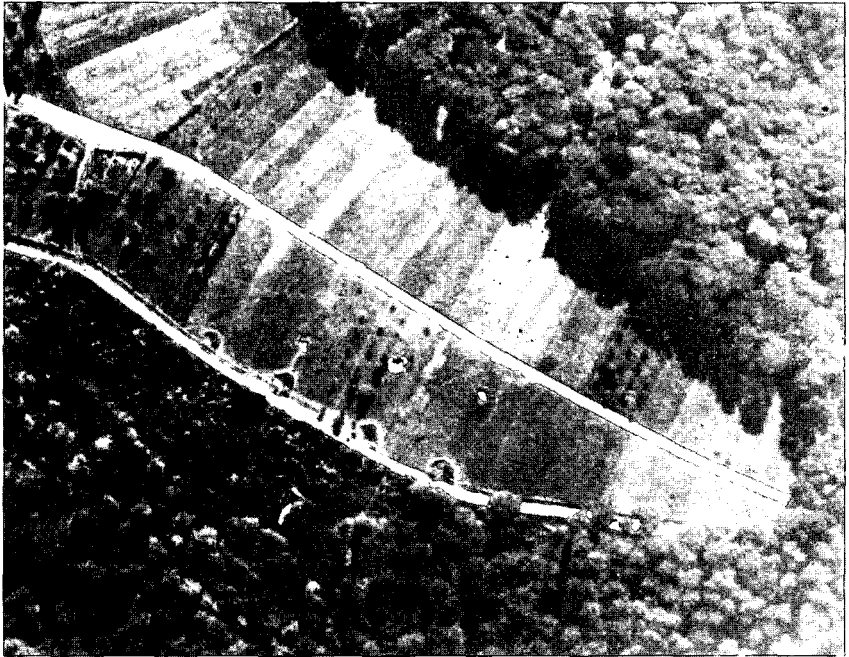

Figure 150. Aerial photo of battery preparing position in a clearing.

be used to cover fire-direction crews and equipment. Radio vehicles should be dispersed and concealed. In some places they may be dug in and covered with nets. In certain situations the only solution may be to disguise the radio vehicles to resemble general purpose vehicles by adding bows, tops, and false hoods. Where new tracks must be made to reach the command post the tracks are carried past the command post to a logical termination.

92. Pattern Painting of Field Artillery

a. Field artillery pieces to which painted camouflage patterns have been applied are difficult for the enemy to distinguish. Figure 154

shows a pattern painted artillery piece. However, the paint does not give complete concealment to the piece or its emplacement. Pattern painting is only an aid to concealment.

b. Patterns are designed for use in different types of terrain. Colors in each pattern should be chosen to match the dominant colors of the particular terrain in which the piece will operate.

- (1) The three-color pattern used for temperate and jungle terrain is shown in figure 155. The three colors are olive drab, field drab, and black.

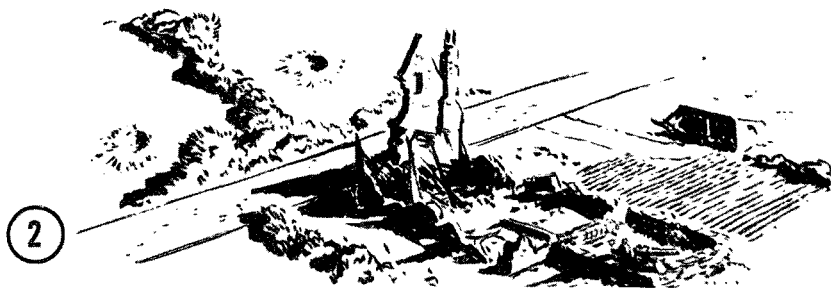

- 1 Debris used for camouflage
- 2 Gun positioned in ruin

Figure 151. Artillery in urban area.

- (2) Figure 156 shows a 155-mm gun painted with earth yellow and olive drab. This pattern is suitable for light desert backgrounds. In reddish desert backgrounds, the earth yellow should be changed to earth red.
- (3) The howitzer in figure 157 is painted white for snow terrain with wooded areas, with about 15 percent of the piece left olive drab. In predominant snow areas, where there are no woods to break up the snow, the piece should be painted solid white.

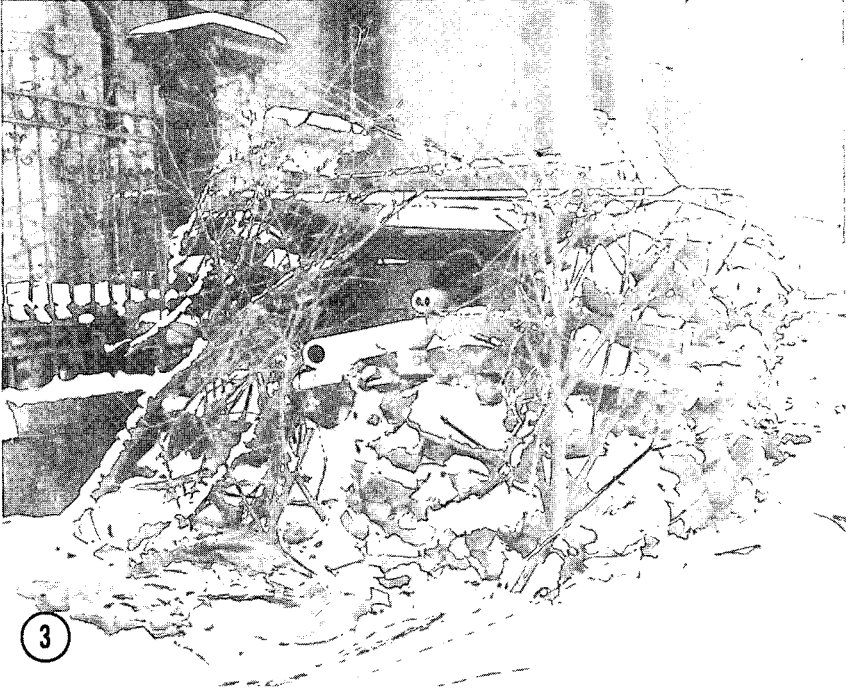

3 Gun camouflaged with rubble

Figure 151—Continued.



1 120-mm gun sited in desert area



2 105-mm gun sited in ruins, in barren area

Figure 152. Artillery in desert area.

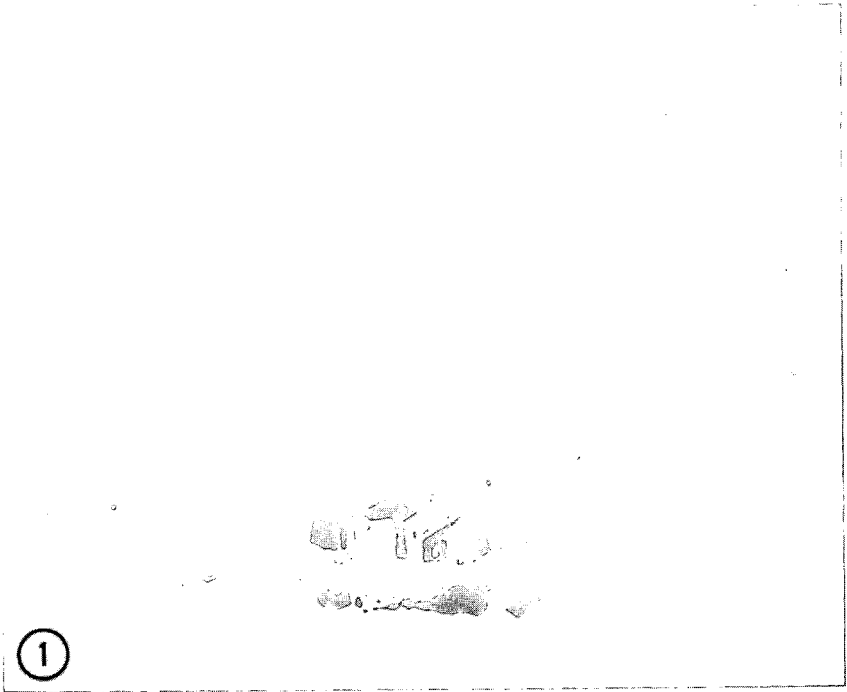

1 Camouflage aided by recent snow



2 Incorrect camouflage in snow area

Figure 153. Artillery in snow areas.

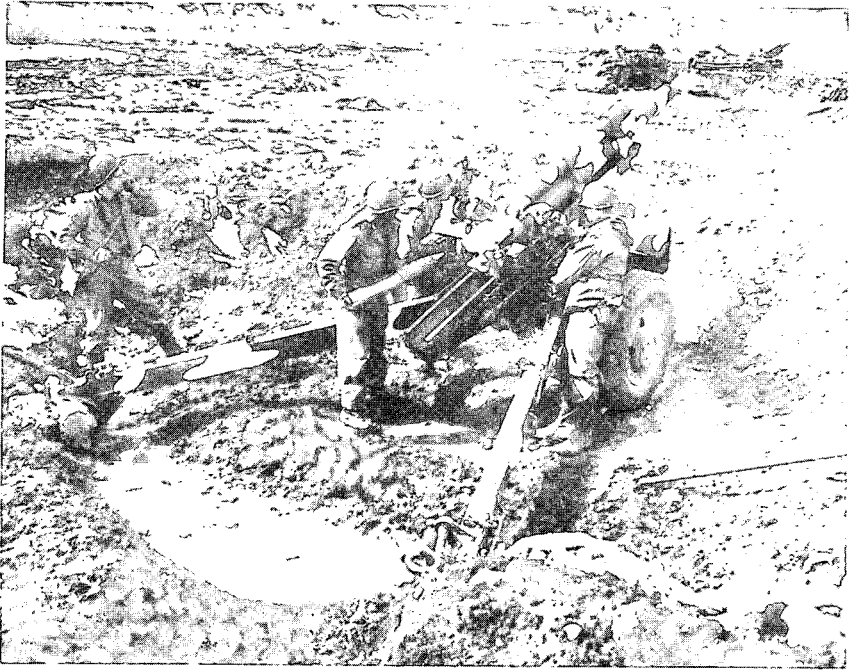

Figure 154. Pattern painted artillery.

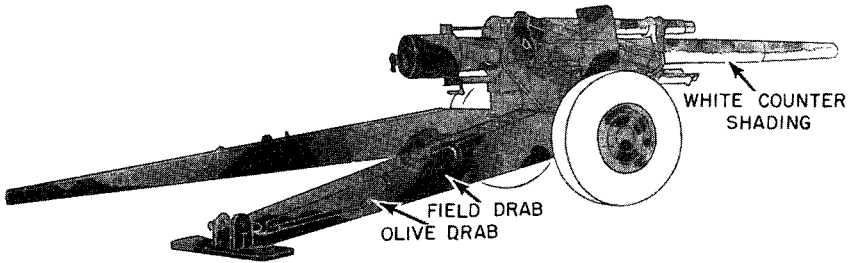

Figure 155. Pattern for temperate and jungle terrain.

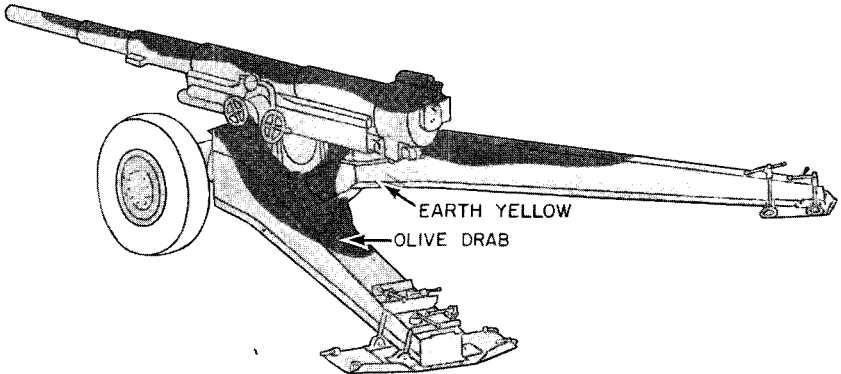

Figure 156. Pattern for light desert terrain.

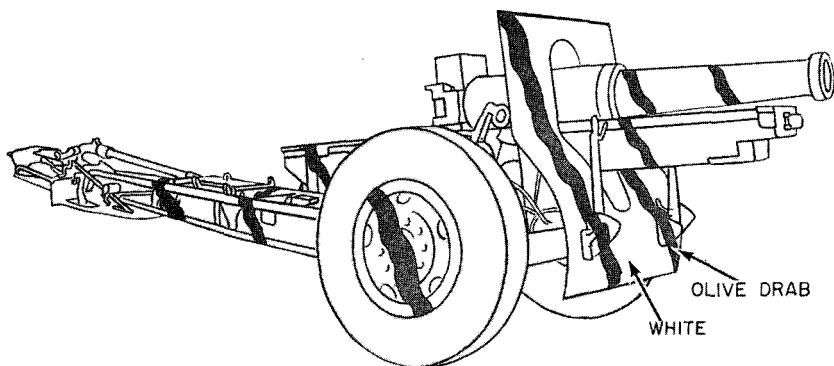

Figure 157. Pattern for mottled snow area.

Section II. GUIDED MISSILE

93. General

In planning the camouflage requirements for concealing a typical guided missile firing battery, consideration must be given not only to the missile itself but also to support areas and support and organic equipment that is in the general area of the firing position. This includes the missile fueling area (when applicable), storage dumps, ground guidance equipment, and missile erectors and other special equipment (when applicable). If observed, these areas, equipment, and installations will indicate to the enemy observer that there is missile activity in the area (1, 2, and 3, fig. 158). In siting the firing position, several prerequisites should be taken into consideration: the area should be large enough to permit dispersion of the firing position; in most instances the firing pad must be level; and the need for entrances and exits for fueling when fueling is accomplished with the missile in the erect position. This will require considerable earth work, resulting in scarring the area. One method of concealing the scarred area is to confine it and remove the sod. The sod is replaced over the scarred area as soon as construction is completed. In constructing the emplacement consideration should be given to the shape of the emplacement. For example, circular shaped positions in terrain where the pattern is predominately rectangular will be eye-catching to the enemy observer. The shape of the firing position should be modified to resemble the most common ground pattern in the immediate terrain.

94. Concealment During Movement

a. Day. The problem of concealment in movement is quite complex since a missile battery on the march is vulnerable to hostile enemy observation, especially during daylight hours. To the enemy

observer, the characteristically shaped special equipment is a definite giveaway of the type of missile organization on the move. The identity of one special piece of missile equipment (1 and 2, fig. 159) is indication that a Corporal guided missile unit is on the move.

b. Night. One method of movement of a guided missile organization to insure maximum concealment is to move at night under blackout conditions. The organization should arrive at the predesignated destination in ample time to conceal the firing position and all equipment during the hours of darkness.

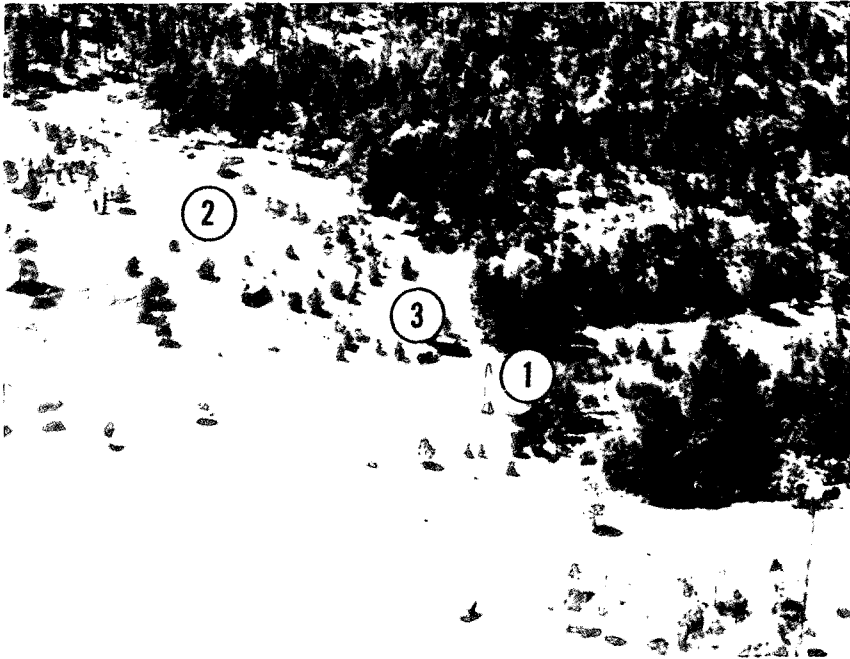

1 Missile 2 Tracks 3 Organic equipment

Figure 158. Uncamouflaged missile positions.

95. Siting

a. General. Prior to occupation of a firing position a thorough reconnaissance of the area to be occupied should be accomplished, taking into consideration the tactical situation, the possibilities of both concealing and dispersing the firing position, and the availability of access and supply routes. These same requirements should be considered when selecting alternate positions. During the occupation of the site and the moving in of personnel, equipment, ammunition, and other supplies a traffic circulatory plan should be in effect which is similar to the traffic plans for vehicles, artillery, and bivouacs. These traffic loops should be concealed and other roads and paths within the firing position should either be wired or taped in to insure their

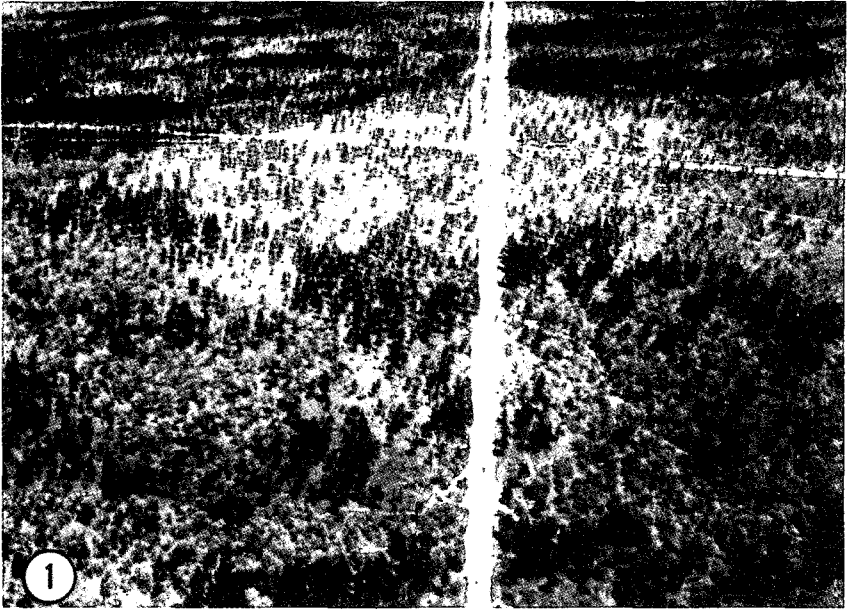

1 Oblique view



2 Closeup

Figure 159. Aerial photo of a missile unit in movement.

use (fig. 107). When access routes do not exist, the number of new access routes should be kept to a minimum and planned to conform to the surrounding terrain pattern. Routes of approach should pass near the firing position and accessory locations and go beyond the firing position to a predetermined logical destination (fig. 89).

b. Siting in Open Terrain. In siting a firing position in barren terrain it must be remembered that from the air the terrain pattern appears to be mottled due to scattered scrub growth, rock outcrops, and irregular ground formations (fig. 160). In siting the firing positions, if advantage is taken of the dark shadows cast by the outcrop of rocks, irregularities in the terrain, and scrub growth, both the firing position and equipment organic to the firing battery usually may



Figure 160. Net used to conceal missile in the desert.

be blended into the terrain and be inconspicuous. If the terrain is of such a nature that adequate concealment cannot be obtained by taking advantage of the terrain features, then proper siting should be supplemented by the use of camouflage drape nets and drape net sets (fig. 161).

c. Wooded Areas. In siting a guided missile firing battery in a wooded area, a thorough reconnaissance of the area should be accomplished prior to occupancy. This eliminates confusion in moving into the area and results in maximum advantage being taken of natural concealment. For example, if a missile firing battery is sited in a wooded area adjacent to the bend in a river or turn in a road (fig. 162) it may be concealed in most instances with a minimum amount of construction effort. The clearing afforded by the roadway



Figure 161. Drape net set in barren terrain site.



Figure 162. Aerial view of site for missile.

or river serves as an excellent field of fire for a horizontal launch. On the other hand, a vertical launch missile can be sited in the immediate vicinity of a group of large trees which will virtually absorb the shape and shadow of the missile in the erect position. In areas of sparsely wooded terrain, concealment of the missile and organic equipment is aided by the use of nets (fig. 163).

d. Towns and Industrial Areas. An ideal place for siting guided missile firing positions is in towns and industrial areas where buildings are massed and of various sizes (fig. 164). The equipment organic to the firing battery may be concealed inside the buildings or in



Figure 163. Concealment of missile aided by use of net.

the shadows. The missiles themselves may be placed alongside the spire of a church or the smokestack of a factory and remain inconspicuous.

96. Concealment of Blast Area

a. The blast area created by the heat and velocity of pressure in firing the missile leaves a burned or scarred area that should be concealed immediately after firing, because it is a definite sign of missile activity and one of the first clues for the enemy observer.

b. One aid in concealing the blast or burned area is to confine it as much as possible. This may be accomplished by watering down the area in the immediate vicinity of the launcher or by placing a fire-

proof pad under the launcher. In the event none of the above solutions are feasible, the missile may be sited under trees or other types of natural concealment and moved out into the open to fire and after completion of the firing mission the launcher may be sited in its original location. This will eliminate the scorching of natural concealment (vegetation, and so on). However, the blast area still exists. This may be concealed by covering the scarred or burnt area with brush, sod, or other vegetation. If drape nets are available, they may be used to conceal the blast area by spreading them over the blast or burnt area in an irregular pattern; or if a drape net set is used to initially conceal the firing position, the re-erection of the

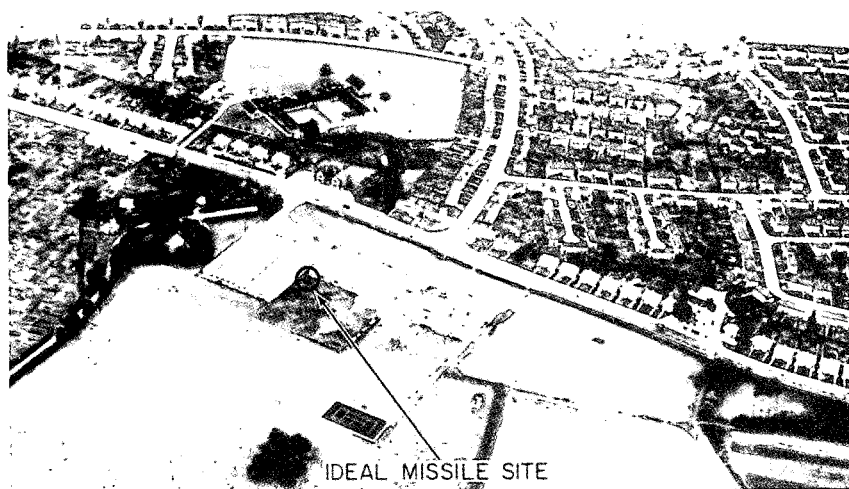

Figure 164. Aerial view of town and industry.

drape net set may conceal the blast area, depending on how large an area is scarred.

c. If none of these solutions are feasible, the scarred area can be toned down by painting the area with a lusterless paint. The color used must blend with the immediate surroundings of the firing position.

97. Painting of Missiles

The missile may be painted a disruptive pattern to blend with the surrounding terrain, provided the paint used does not affect the temperature requirements of the missile. Missiles painted with highly reflective paints, to reflect solar heat, should be covered with a cloth or canvas cover dyed to match the predominant terrain color. The cover will provide camouflage for the missile until positioned for firing.

CHAPTER 11

AIRFIELDS, LANDING SITES, AND AIRCRAFT

Section I. AIRFIELDS AND LANDING SITES

98. General

a. Camouflage is one of the first considerations during the location, design, construction, and operation of an airfield or landing site, regardless of whether the construction classification of the installation is pioneer (fig. 165), hasty (fig. 166), or deliberate (fig. 167). Detailed information on airfields and landing site selection and construction is found in TM 5-250 and TM 5-251.

b. The tactical situation and the personnel, materials, and time available determine the amount of effort to be expended on camouflage. Friendly aircraft, under certain conditions, can provide cover against enemy aerial observation and attack. With air superiority, camouflage may become a secondary consideration. However, with a temporary loss of air supremacy, camouflage becomes of immediate importance.

c. Landing sites and airfields are easily identified from the air because of their size and characteristic features (fig. 167). The most noticeable features of airfields or landing sites are the straight, smooth runways. This creates a pattern unlike that made by any existing civilian road system. The second conspicuous set of patterns is composed of the troop housing areas, operational structures, and circulatory road net inclosing the entire installation.

d. Uncamouflaged, an airfield or landing site presents a clear target to attacking aircraft (fig. 168). The vital points for attack, structures, dispersal areas, runways, and troop housing areas, are easily pinpointed. Much can be done, however, to render an installation a difficult target. When terrain and time are favorable, an airfield can be completely concealed. This can be done only by the careful preparation, execution, and maintenance of a camouflage plan.

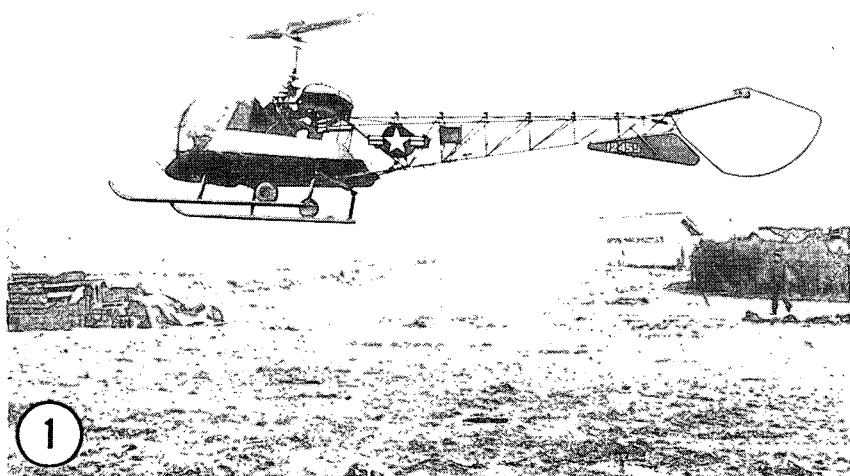

1 Pioneer heliport



2 Pioneer airfield in use during Korean conflict

Figure 165. Pioneer aircraft installations.

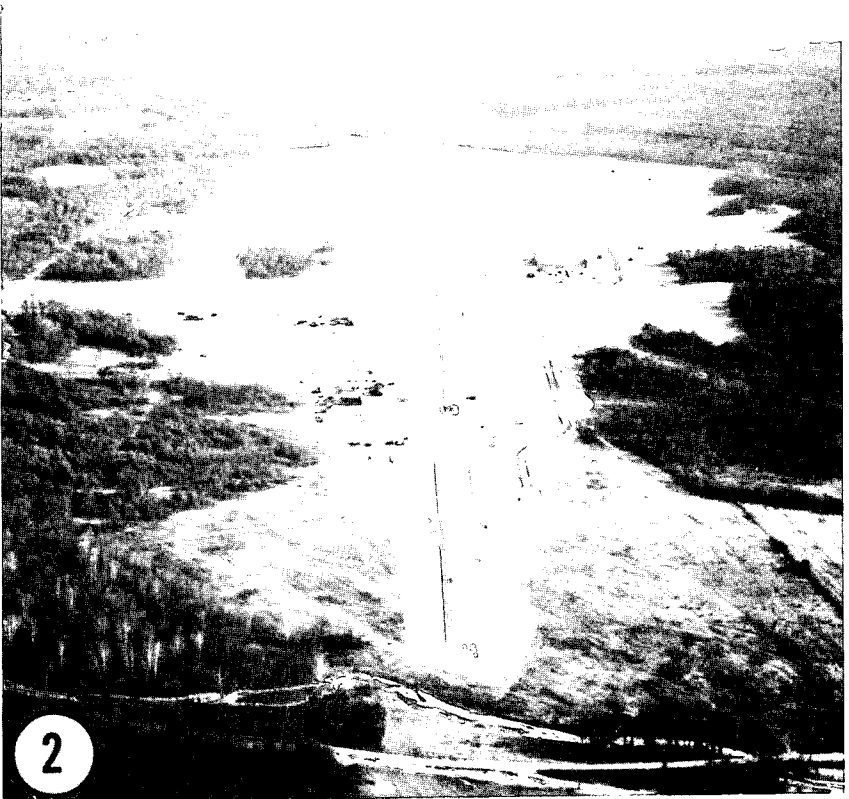

Figure 166. Hasty airfield built during World War II.



1 Deliberate heliport

Figure 167. Deliberate aircraft installations.



2 Deliberate airfield

Figure 167—Continued.

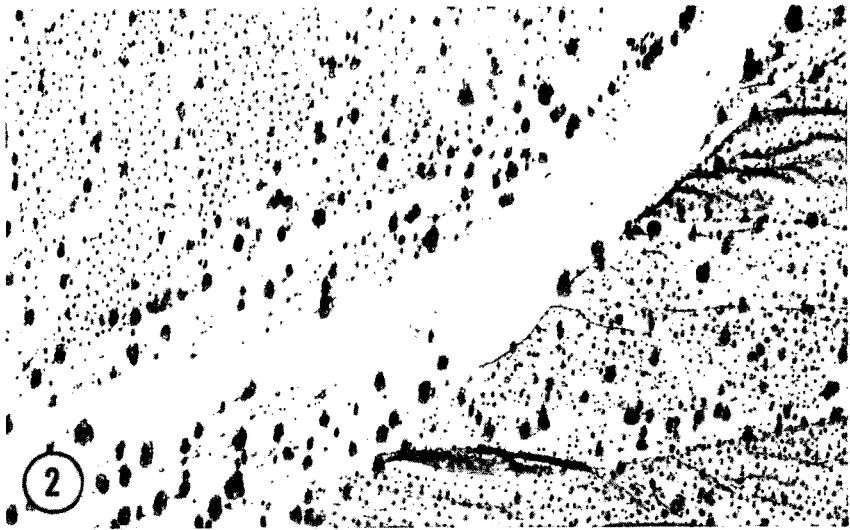
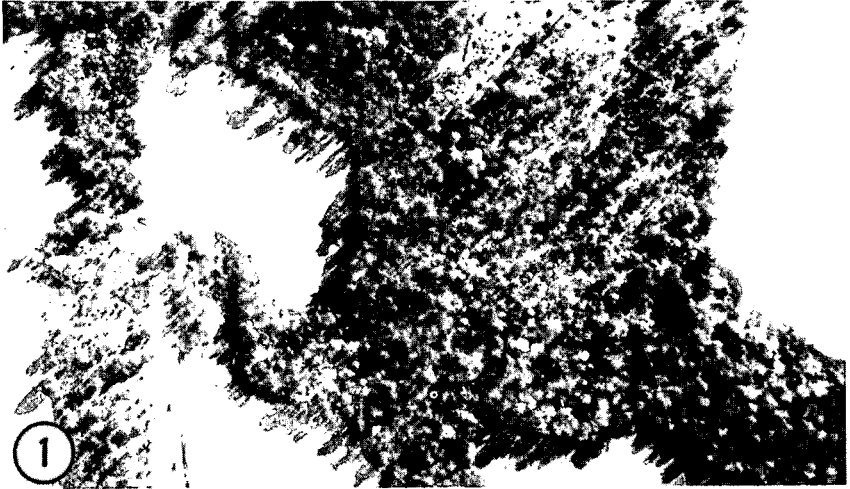

Figure 168. Uncamouflaged airfield.

99. Camouflage Plan

a. The first step in the camouflage plan of airfields and landing sites, as in all camouflage operations, is the study of the terrain. The study should include capabilities of terrain features and natural vegetation in aiding concealment. Air observation and aerial photographs are made in order to study more closely the terrain color and distinctive pattern (fig. 169). After the ground formation, predominant colors, and pattern of the area are analyzed, the camouflage shape, color, and patterns can be planned.

- (1) Dispersed parking sites (fig. 170) should be located within dark and heavily textured parts of the area (fig. 171), avoiding sites where aircraft would be in sharp contrast to their surroundings or close to an unusual or isolated terrain feature. Use should be made of overhead concealment, clumps of bushes, scrub growth, folds in the ground, and other shadow-casting irregularities.
- (2) Circulating traffic should be confined if possible to existing roads and paths for movement within the area and for access to security outposts (1, fig. 172). New routes should be kept to a minimum. Advantage should be taken of overhead concealment (2, fig. 172) and vehicles should be sited close to and along natural terrain lines (3, fig. 172).



- 1 Wooded terrain
- 2 Desert terrain

Figure 169. Aerial photos of types of terrain.

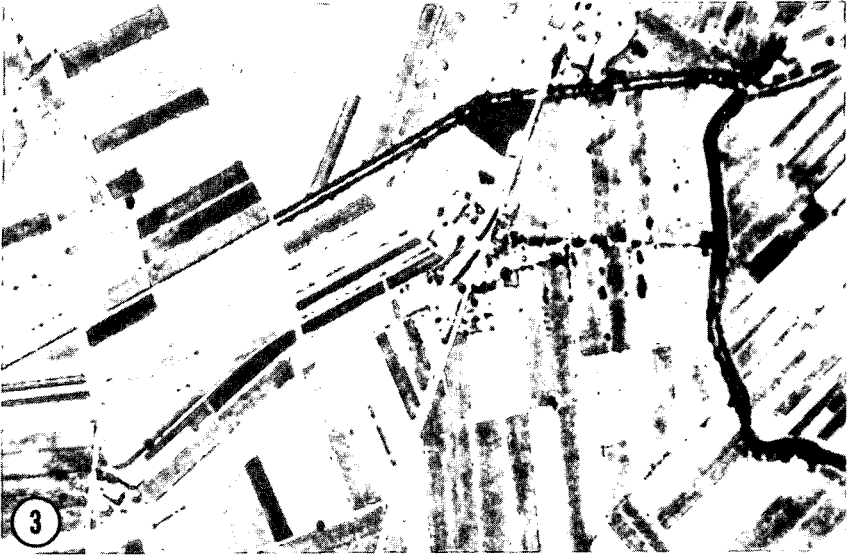

3 Agricultural terrain

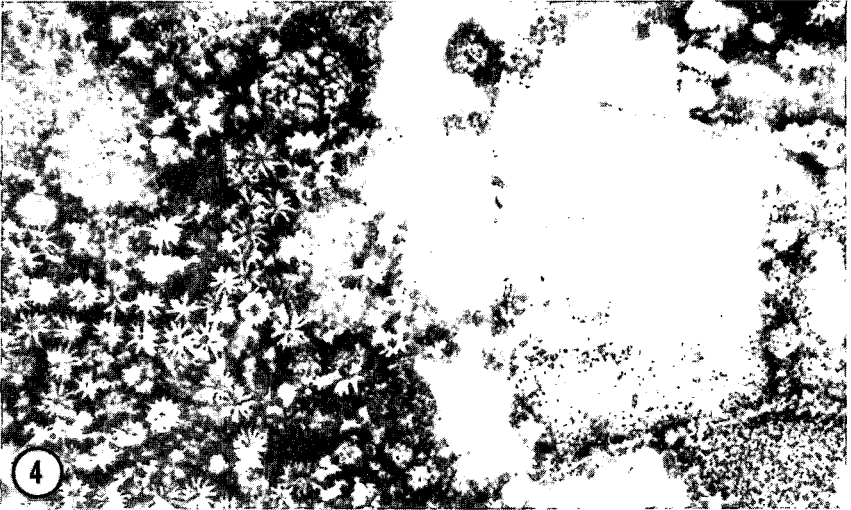

4 Jungle terrain

Figure 169—Continued.



5 Urban terrain

Figure 169—Continued.

- (3) Pioneer Army airfields and landing sites should be located in the least obvious areas that are available. All terrain features must be utilized to the fullest extent for good concealment.

b. Runways. Familiar ground patterns of farming areas which may be created on an all-turf airfield situated in agricultural terrain are illustrated in the aerial view below. Here the runways are made to appear as orchards (1, fig. 173) and cultivated fields (2, fig. 173), normal in size, separated by hedges (3, fig. 173) and narrow country lanes. The principal methods of simulating these terrain patterns are burning (1, fig. 174), distributing material, such as used crankcase oil (2, fig. 174), and controlled fertilizing and mowing (3, fig. 174).

- (1) The greater the traffic at an airfield, the more difficult it becomes to camouflage runways and taxiways. Sod airfields do not ordinarily present too great a problem unless paths have been worn through heavy and continued use. In such a case it may be possible to conceal the true purpose of the strip from air observation by extending the strip outline into a road or group of trees, thus making it appear to be a road or trail. Pilots must cooperate by restricting their landings, takeoffs, and turnarounds to designated areas and refrain from making new tracks that may be observed from the air. Portable landing mats and prefabricated metal panels laid upon the natural surface may be concealed by encouraging the growth of grass. The simulation of roads

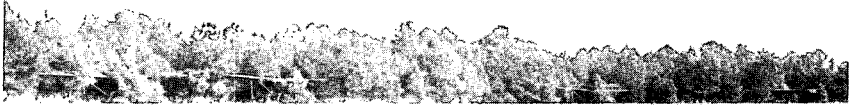

①

1 Parked airplanes

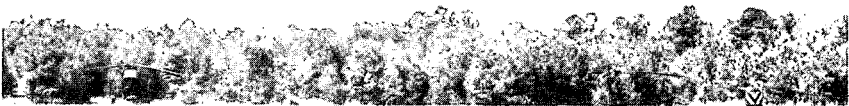

②

2 Parked helicopters

Figure 170. Dispersed parking.

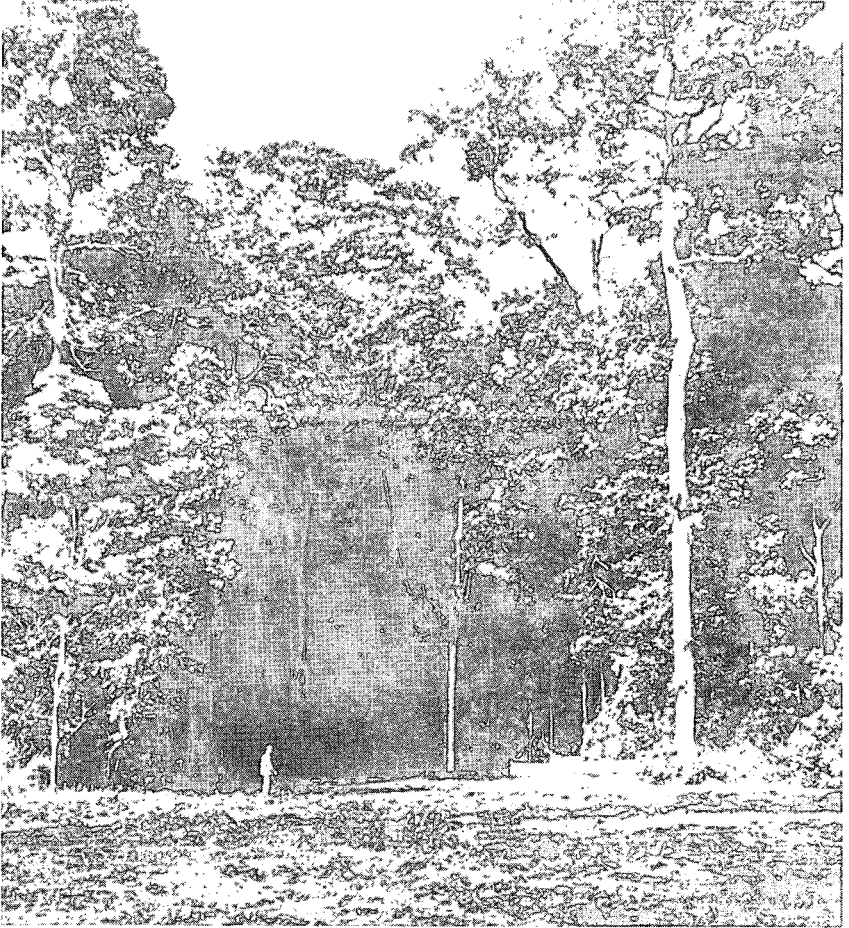
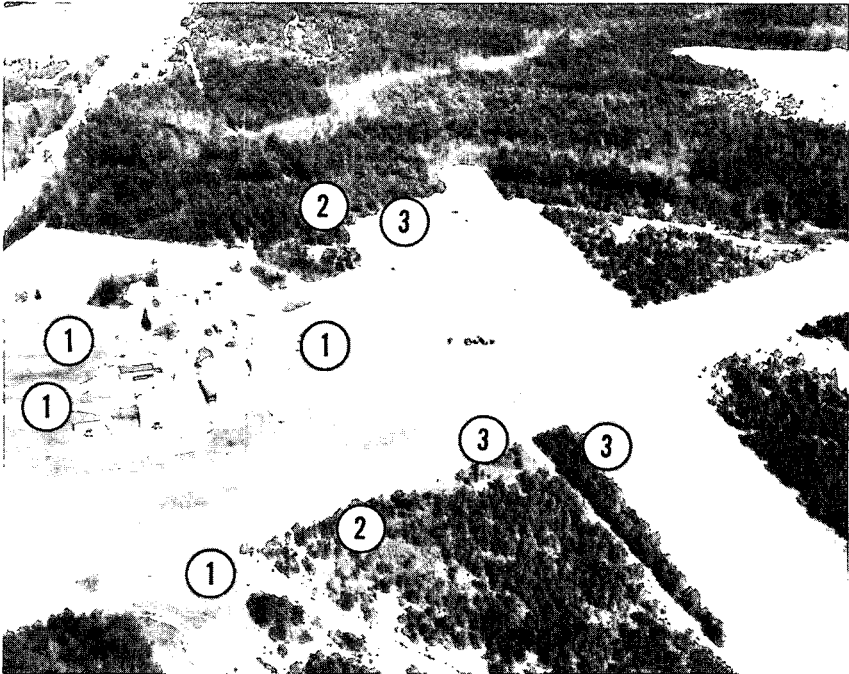
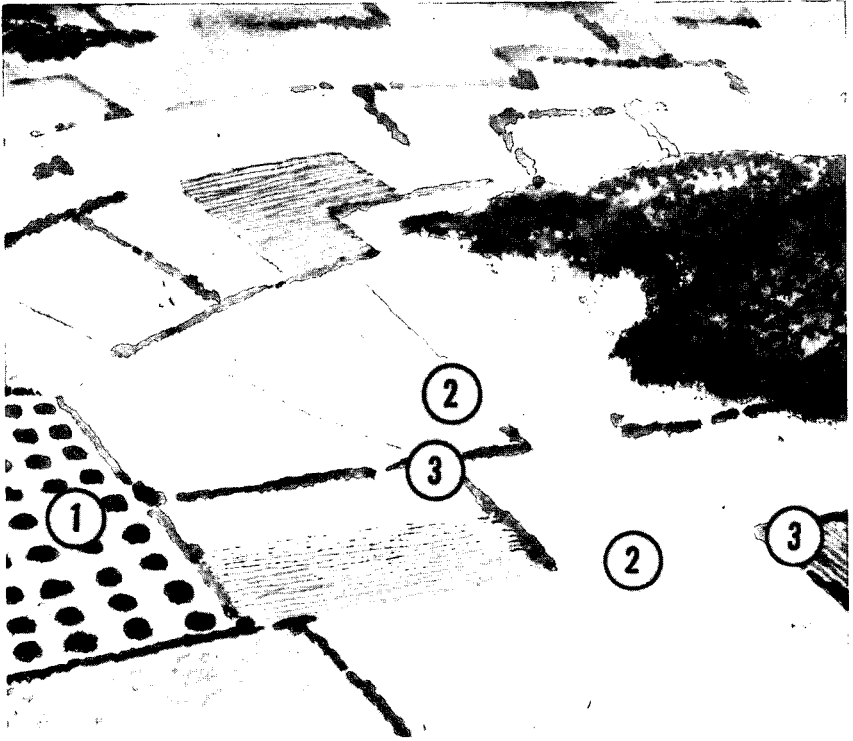

Figure 171. Parking site located in dark, heavily textured terrain.



- 1 Existing roads
- 2 Overhead concealment
- 3 Natural terrain lines

Figure 172. Features to consider in good traffic plan of airfield.



- 1 Orchard
- 2 Fields
- 3 Hedges

Figure 173. Ground patterns created on all-turf airfield.

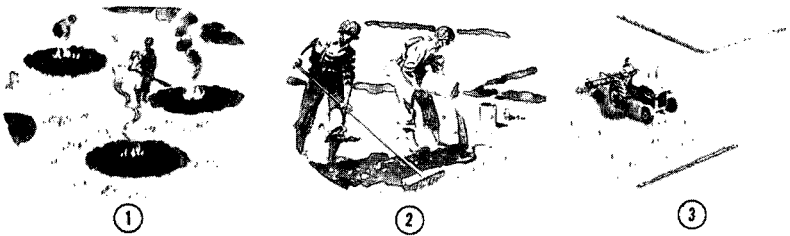

- 1 Burning
- 2 Distributing material
- 3 Mowing

Figure 174. Methods used to simulate ground patterns.

or paths, or both, crossing the runways is an effective method of disrupting the regular pattern. Hard surfaced runways and taxiways may be textured and colored to blend into the surrounding terrain by the use of various materials described in FM 5-22.

- (2) It is to be expected that the enemy will be able to discover the location of an airfield, particularly the runways and taxiways, through a careful study of aerial photographs, intelligence reports, and from observation of military activities. In many cases, it is not the intent of camouflage to conceal

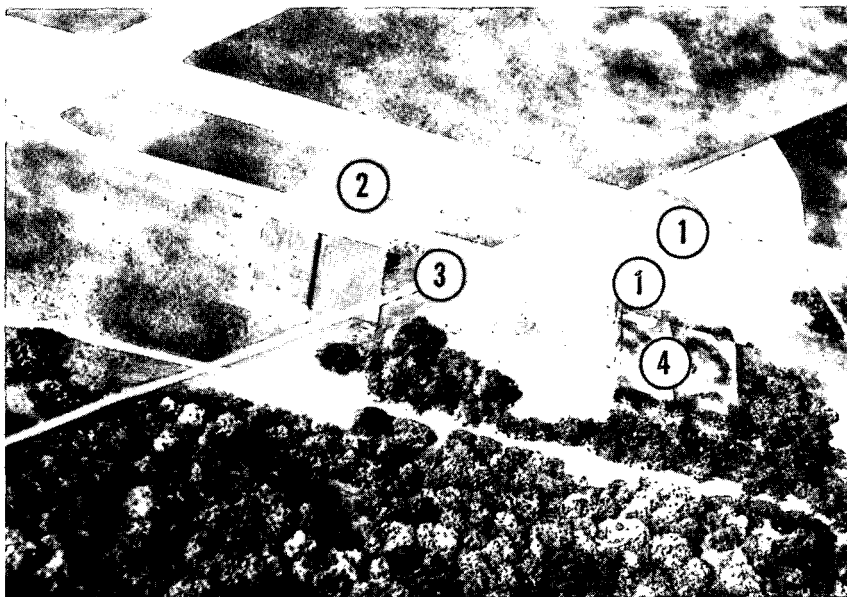

- 1 Portion of runway toned down
- 2 Untreated portion of airfield
- 3 Simulated road
- 4 Toned down structures

Figure 175. Texturing of airfield and simulation of road on installation.

the runways completely but to reduce their visibility to a point where the enemy bombardier will have difficulty in obtaining a clear sight from the distance necessary for successful bombing and to eliminate a target of opportunity. Figure 175 shows the runway of a tactical airfield. The left portion of the runway is toned down (1, fig. 175). The right portion has not been treated (2, fig. 175). A simulated road crosses buildings and runways (3, fig. 175). Toned-down buildings are shown in 4, figure 175. Paint, alone, applied to a smooth runway surface does not produce a satisfactory toned-down. Texturing material, such as stone chips, must

be firmly attached to the runway by means of an adhesive to create the texture necessary to blend the runway surface with the terrain. Figure 176 shows the contrast between a textured and an untextured portion of a runway, and the contrast between painted and textured runways.

c. Overall Pattern. When the expenditure of materials and labor is permissible, the next step in camouflage of airfields is the application of an overall pattern. The aim of this step is to give the

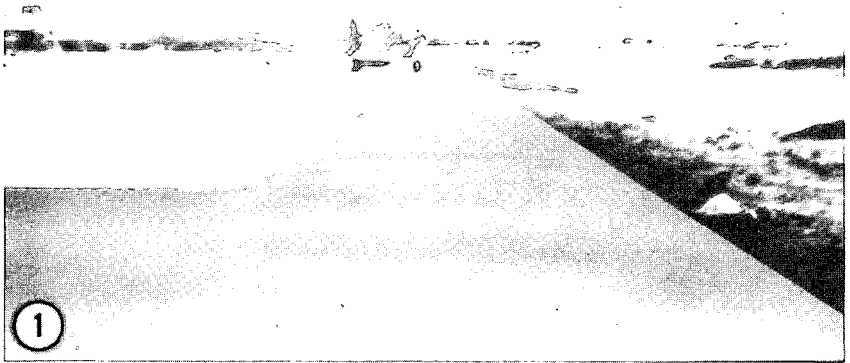

1 Foreground of runway has been painted

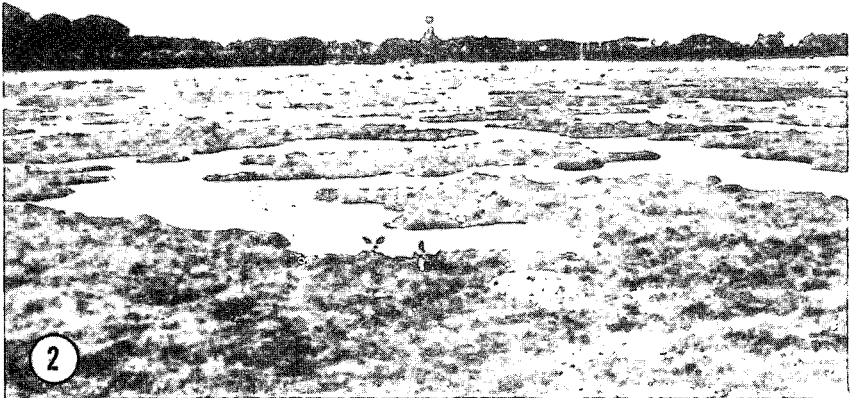

2 Texturing material has been added to runway

Figure 176. Contrast between textured and an untextured portion of runway.

entire airfield the appearance of the surrounding country. 1, 2, and 3, figure 177, show an airfield on which hedge and tree and grass patterns have been simulated by texturing and painting the surface of the entire base. The size, shape, and color of the newly created ground patterns have been designed to match the patterns of the surrounding country. The roads which have been simulated on the airfield continue to actual road nets existing outside the installation (4, fig. 177).

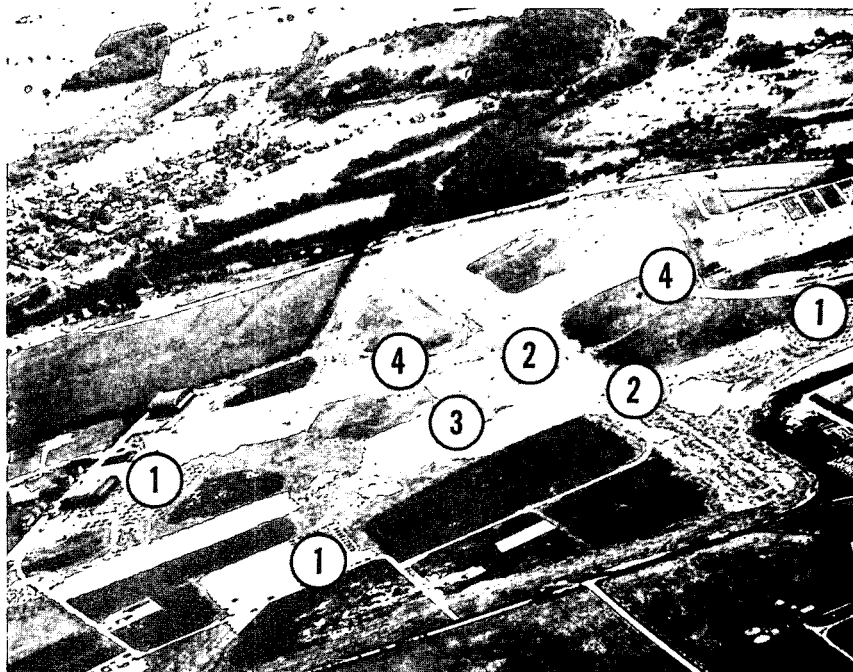

- 1 Simulated trees
- 2 Simulated grass terrain
- 3 Simulated hedges
- 4 Simulated roads

Figure 177. Airfield with simulated terrain features.

d. Treatment of Revetments. Because revetments have a regular shape and a contained shadow, which is a shadow created within the revetment by the revetment itself, their camouflage is a difficult problem to solve. When revetments are partially dug into the sides of hills, the problem is easier. The more irregular the shape and the more gradual the slopes of revetments, the easier they are to camouflage. Earthwork revetments may be seeded to give them texture and color and to conceal new spoil. This treatment may be improved by planting small shrubs or vines to break up the form

and contained shadow. If time and facilities permit, tree planting is an effective measure (fig. 178). The construction of simulated civilian structures, such as farm buildings, over revetments is an elaborate method of concealing them. Another method requiring much material is to completely screen the inclosure of a revetment with overhead netting. However, this method rarely fools an aerial camera, although it may succeed in concealing the fact that an aircraft or supplies are beneath the netting.

e. Large Operational Structures. Although maintenance facilities and other structures are partially blended into their surroundings either by a single-color tonedown or by pattern-painting, these

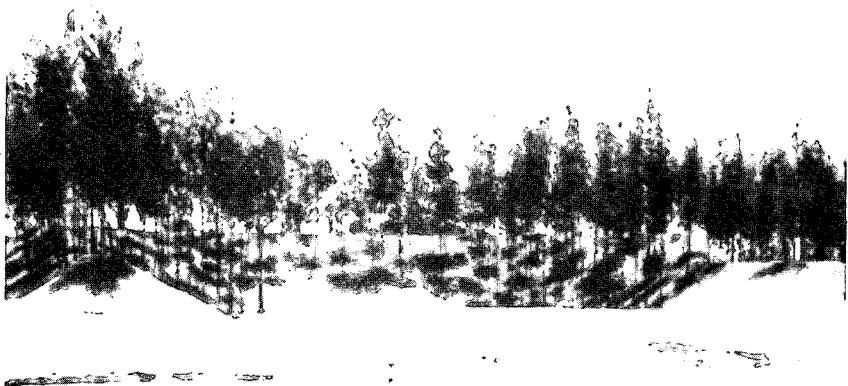

Figure 178. Trees planted on revetment to break up shape and shadow.

measures do not eliminate the large shadows of such structures (fig. 179). The most practical way to eliminate these shadows is to site structures among trees or tall shrubs. Trees close to a building distort and break up the shape and size of the shadow. If necessary, trees and shrubs can be transplanted near structures to supplement existing growth. Pattern painting is combined with this growth to complete the blending of such structures with the terrain (fig. 180). When the terrain has little or no vegetation, nets supported on cables and garnished with artificial materials are stretched from the outer edge of structures to the ground in a gentle slope (fig. 181). If the terrain is mottled with scattered growth, the sloping nets should be blended into the terrain pattern created by the scattered growth.

f. Small Structures. Methods of concealing small airfield structures include proper site selection, digging in, construction resembling

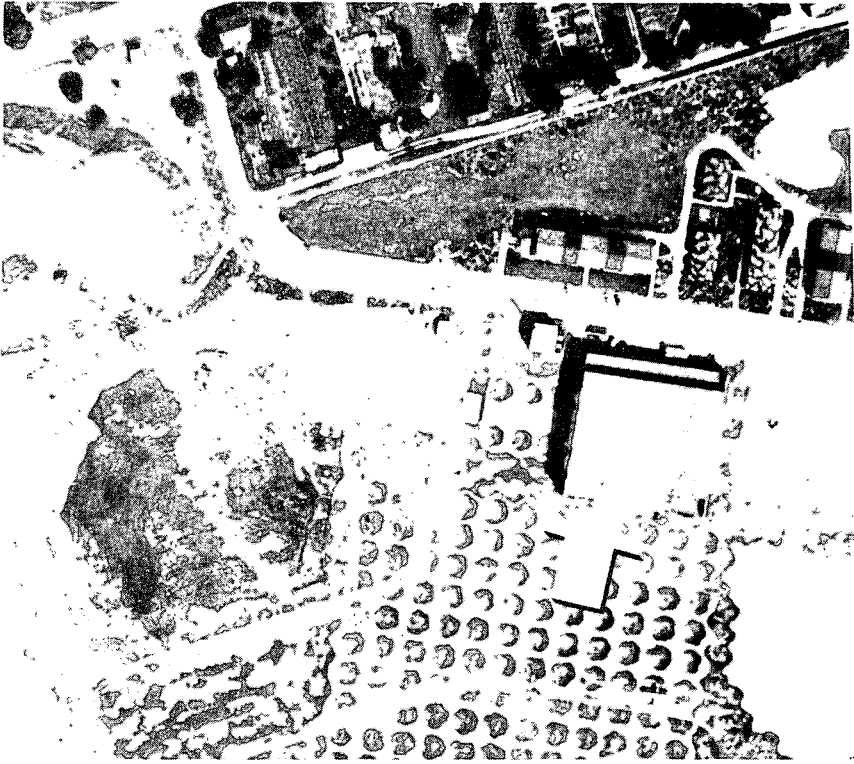

Figure 179. Airfield structure pattern painted but obvious because of large shadow.

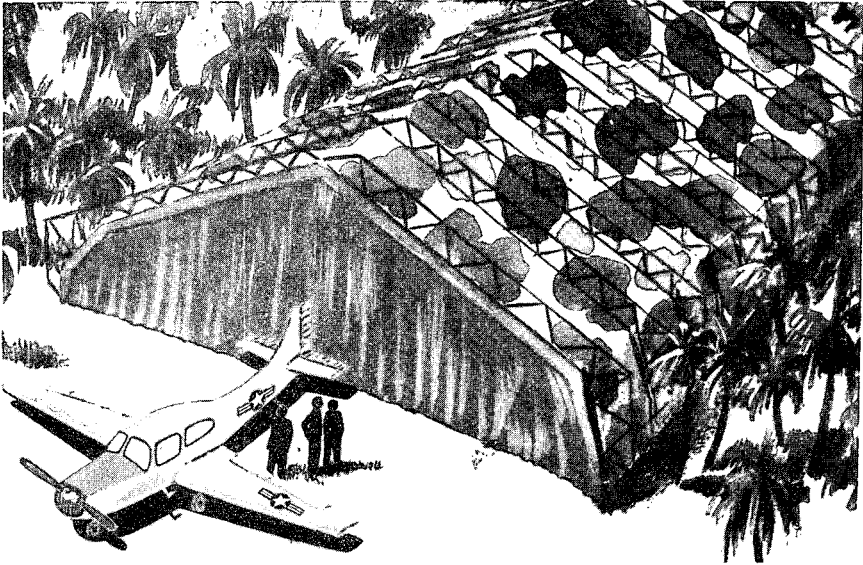

Figure 180. Pattern painted structure sited among trees to eliminate shadow.



Figure 181. Slope net.

native structures (fig. 182), and toned down by pattern-painting or texturing and by use of artificial and natural materials. Isolated operational structures, such as radio and control huts, are best concealed by digging them in and covering them with natural materials (fig. 183).



Figure 182. Airfield structure built to resemble native housing.

g. Dispersed Cantonments. A typical well-dispersed cantonment is shown in figure 184. Concealment offered by existing trees and shrubs has been used to advantage. The hutments on the left are more conspicuous than those on the right because the buildings have not been toned down. Except at low altitudes, the righthand can-



Figure 183. Operational structure dug in.

tonment area might easily escape direct enemy observation. Cantonment buildings can be toned down with issue camouflage paint. For a hasty job, one well-chosen color is to be used. When time permits, disruptive patterns done in two or three colors increase concealment against low-altitude observation.

h. Camouflage Discipline. Refer to paragraph 12*b*.

i. Landing Aids. Panels and other landing aids are displayed only when required. When pilots are familiar with the landing area, the aids are removed and displayed only for visiting aircraft.

j. Aircraft Parking. Adequate parking areas for visiting aircraft should be provided together with signs or other means to guide pilots to concealment.

k. Field Lighting. Field lighting must be concealed to prevent ground or oblique aerial observation. Light emitted from airfield lighting fixtures can be controlled by use of the combat hood attached to all fixtures for this purpose. Fixtures may be blended into the

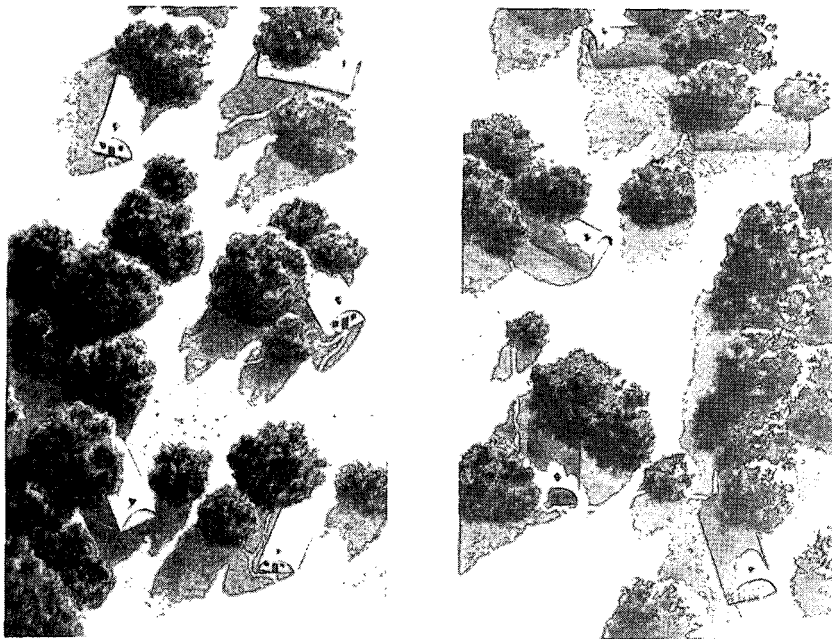

Figure 184. Dispersed cantonment.

terrain pattern by use of natural materials or by painting and texturing to match the terrain color. See TM 5-251 for a description of runway and landing area lighting.

100. Illustrating Camouflage Plan for Airfields

a. Major steps in the camouflage of an airfield are shown in the following series of illustrations. Camouflage construction proceeded concurrently with the construction of runways, taxiways, housing, and technical buildings. The camouflage plan consisted of leaving undisturbed many of the farm groups existing in the area, texturing and painting all paved surfaces, and frequent use of netting



1 Proposed layout



2 Construction scars

Figure 185. Illustrating camouflage plan for airfield.

for purposes of hiding, blending, and deceiving. Uniformity of texture was given to artificial ground patterns, where they extended beyond the limits of paved surfaces, by the use of stabilized mats, which were not designed to carry traffic. Texturing materials were wood chips, corncob chips, and sand. Textured and painted patterns represented solid fields, striped and mottled fields, buildings, and trees. Some roads and buildings were simulated by spraying ground with a weed-killing chemical.

b. An aerial photo of site and surroundings before work was started is shown in 1, figure 185. Proposed layout is superimposed to show relationship to surroundings. 2, figure 185, shows construction scars.



3 Large net has been erected over parking area

Figure 185—Continued.

Building roofs have been painted to break up appearance of buildings, but roof netting is not yet installed. In 3, figure 185, a large flattop net has been erected over parking area. Stabilized areas are not yet textured and painted.

c. The photograph in 4, figure 185, was taken from 2,000 feet. It shows the appearance of one runway after stabilized mats have been textured, but before all of them have been painted. The runway has begun to disappear in the pattern of farming sections. In the foreground, within the triangle formed by runways, is a group of abandoned farm buildings left intact. Fields within the triangle continue to be cultivated, bearing crops common to the locality, such



4 Appearance of one runway after stabilized mats have been textured



5 Camouflage plan nearing completion

Figure 185—Continued.

as corn, soy beans, and barley. The texture of fields bearing each of these crops varies from dark to light and great care has been taken in the assignment of crops to fields, in order to produce an overall pattern which is indistinguishable from the pattern of the neighborhood. An aerial photo taken at 10,000 feet, 5, figure 185, shows work nearing completion. Sharp contrasts in mottled fields are being toned down and blended together. Rough fringes of runways are not yet entirely painted. The completed job from 7,000 feet is shown in 6, figure 185.

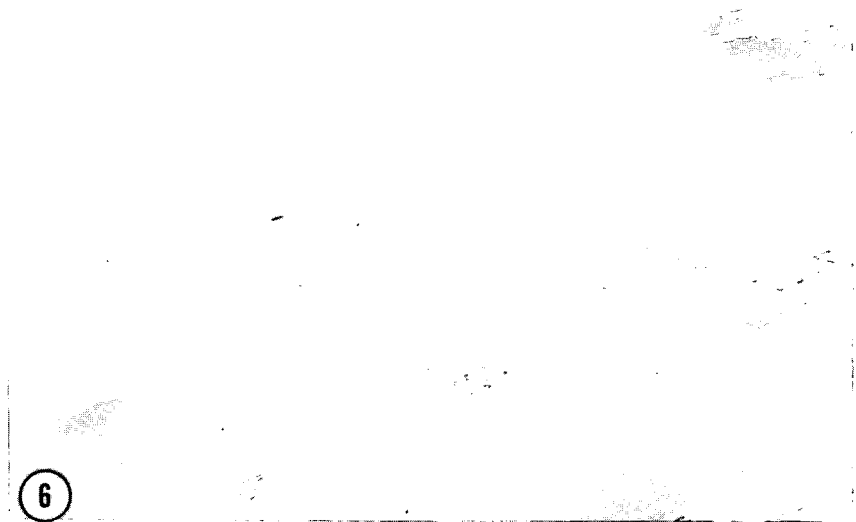

6 Camouflage plan completed

Figure 185—Continued.

Section II. CAMOUFLAGE OF AIRCRAFT

101. Operational Requirements

Camouflage measures designed to conceal Army aircraft on the ground range from simple field expedients in which locally available materials are used, to the use of the shadow net, a net used to absorb the shadow of aircraft. Even without the use of special camouflage materials, aircraft can be overlooked by high-altitude observation if shine and glare are concealed. Aircraft must be able to get into the air quickly and get off the runway quickly when they land. Camouflage measures must not interfere with these operational requirements.

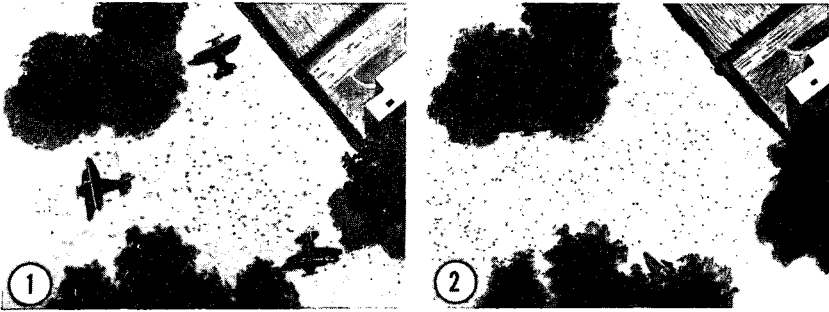

- 1 Incorrect parking
- 2 Correct parking

Figure 186. Parking of aircraft to blend with natural terrain features.

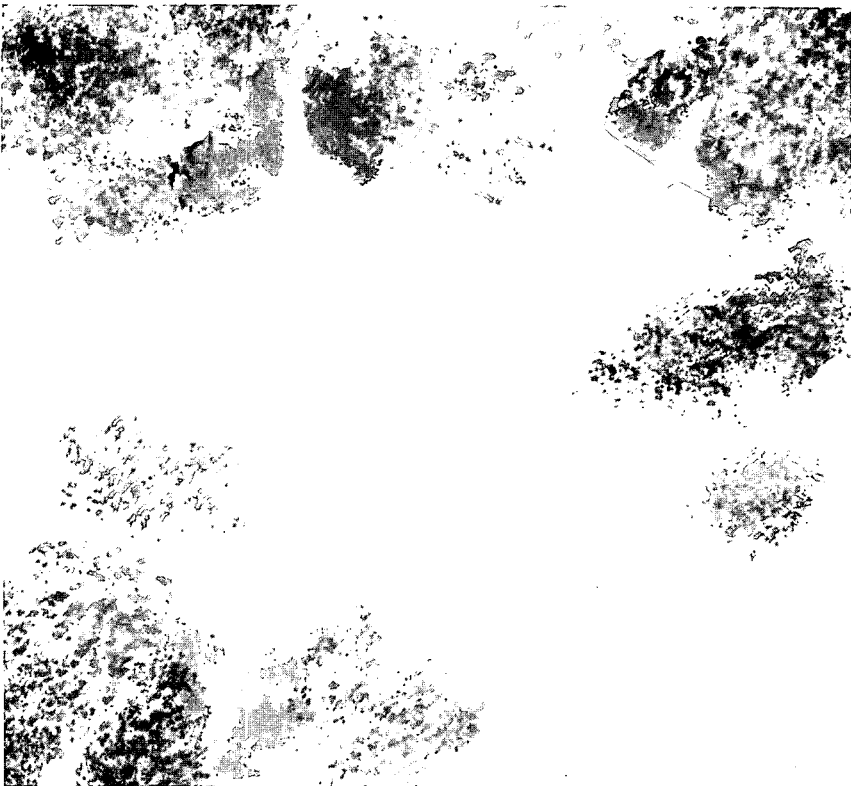

Figure 187. Proximity of shadow-casting trees helps make concealment of Army aircraft effective.

102. Site Selection

Aircraft should be sited in an area where there is quick access to taxiways and runways (1 and 2, fig. 170). For this reason particular care should be taken to select parking sites with which aircraft may be made to blend quickly and easily with natural terrain and foliage which helps to eliminate shadow (fig. 186). In some cases it may be necessary to move aircraft to a new location once or twice a day to reduce the possibility of detection through the changing shadows caused by the various positions of the sun.

a. Wooded Terrain. When choosing a hasty site for the parking of aircraft in wooded terrain, an opening is required for the tail or rotors of the aircraft and also overhanging foliage to break the straight-lined silhouette of the aircraft (fig. 171).

b. Snow Country. In snow-covered terrain concealment is difficult. Some concealment is gained by dispersal to take advantage of scattered tree shadows (fig. 187).

c. Cultivated Areas. In agriculturally patterned terrain hedgerows and patterns of cultivation are used to make aircraft less conspicuous. Tracks of the aircraft are controlled to follow natural planting lines from roads to parking sites (fig. 188).

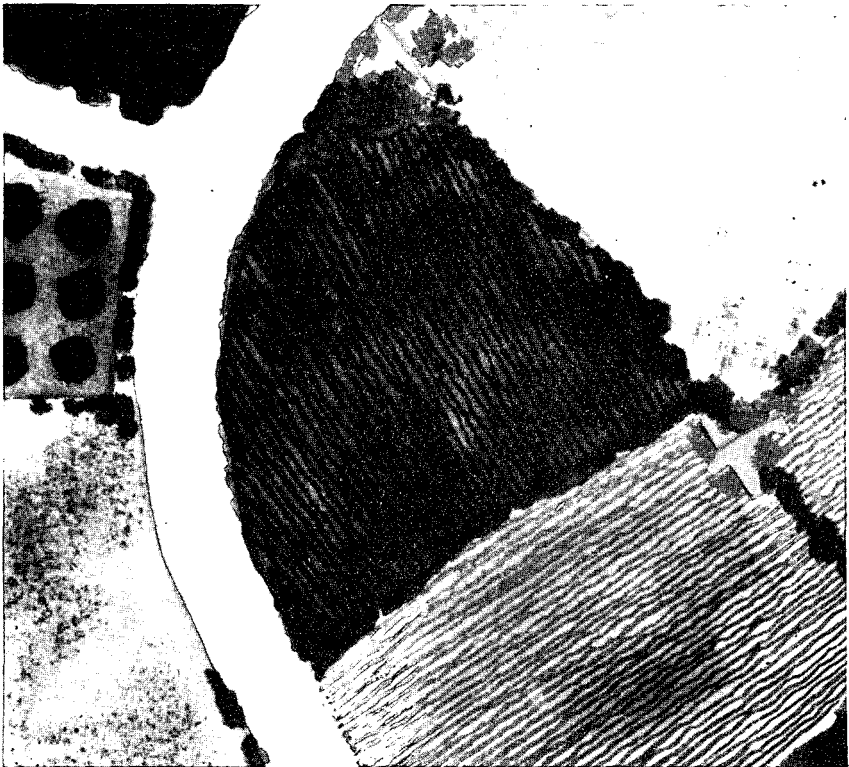

Figure 188. Aircraft in cultivated area.

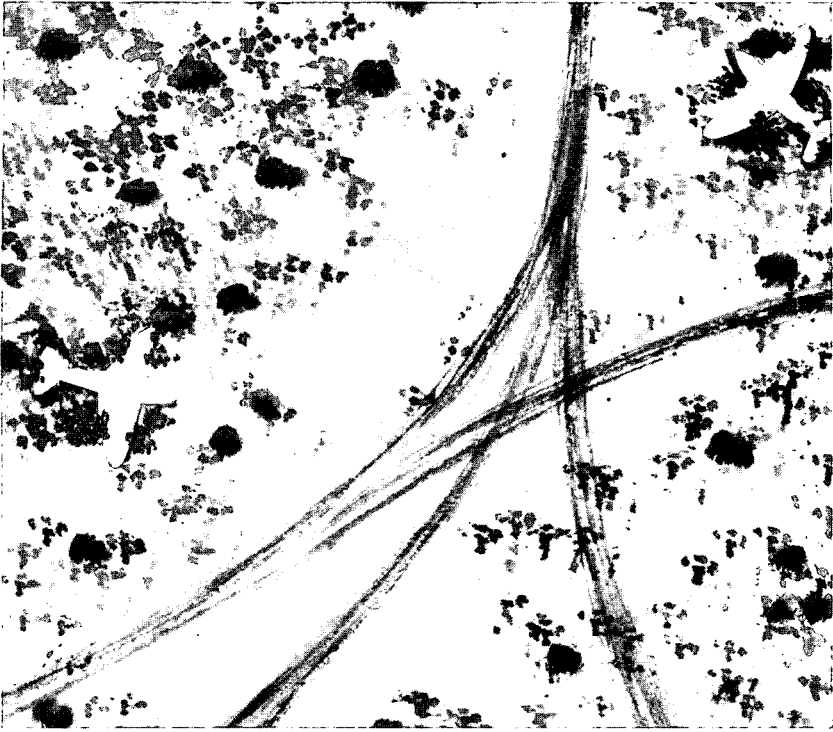

Figure 189. Aircraft in desert area.

d. Desert Areas. Aircraft can be inconspicuous in desert terrain if parked in clumps of scrub growth (fig. 189).

103. Natural Materials

Good site selection in itself does not eliminate the possibility of enemy observers detecting the location of aircraft. To further reduce this possibility, natural materials are used to improvise overhead cover where it is not otherwise available. A few freshly cut branches of trees may be used to eliminate or tone down glaring surfaces such as plexiglas and insignia and to distort the shape and shadow of the aircraft (fig. 190). Where overhead concealment is too thin over aircraft placed between small trees, branches and treetops may be pulled together with rope, wire, or vines. In open and treeless terrain, the shadow of the aircraft may be toned down by parking the plane in a natural depression in the ground and placing scrub growth on the tail assembly, nose, and all glaring surfaces (fig. 191). Although the shadow is still present it is so close under the wing that it is not easily detected from the air.



Figure 190. Foliage used to distort shape and shadow.



Figure 191. Scrub growth used for camouflage in open terrain.

104. Dispersion

Proper dispersion means more than spacing parked aircraft at a distance from one another; it means scattering them so they will sustain the least possible damage from bombing or strafing attack. In figure 192 the aircraft parked at (1) should be moved to parking area (2) for adequate dispersion. Aircraft in line are extremely vulnerable to such attacks. Dispersion also facilitates the use of natural concealment and thus reduces the visibility of targets. Properly dispersed aircraft offer the enemy an unprofitable target.

105. Track Concealment

The enemy observer may not be able to see aircraft which are well concealed or dispersed on the ground (2, fig. 193). However, if he sees tracks leading from a landing strip or taxiway to the parking

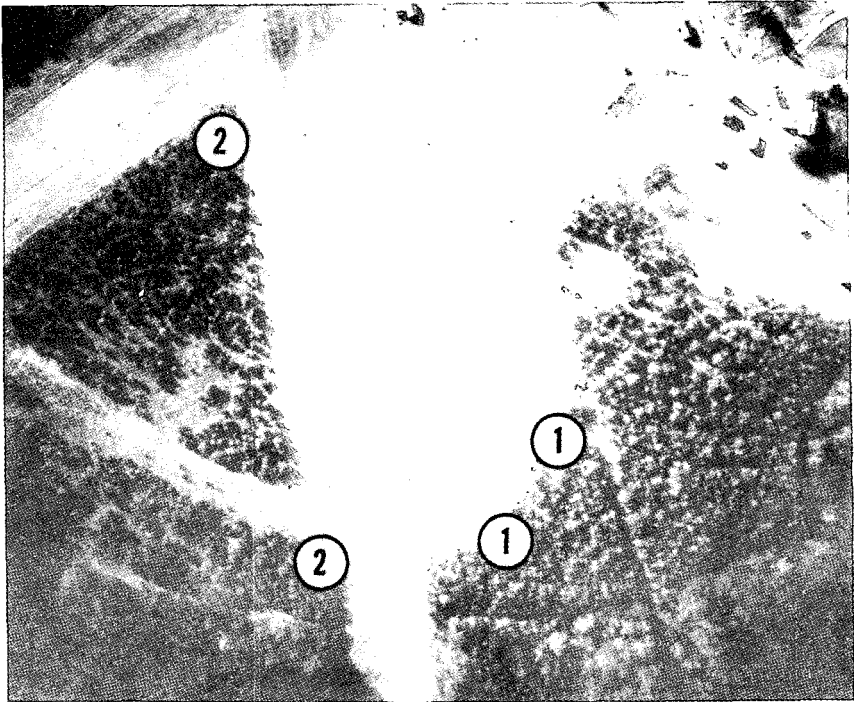

- 1 Improper parking locations
- 2 Parking with adequate dispersion

Figure 192. Dispersed aircraft parking.

area or a wooded area, he can often determine the type of aircraft (2 and 3, fig. 193). To lessen this possibility the tracks must be concealed by one of several methods. Cut vegetation may be placed over the tracks (1, fig. 193). The tracks may be brushed out with saplings, shovels, or brooms, or it may even be necessary to plant grass.

106. Shine and Insignia

a. Light reflects from metal and plexiglas surfaces with a shine that can be seen from great distances. The shine of uncovered metal and plastic surfaces can be detected through well-garnished camouflage nets. The moment an aircraft is parked camouflage must begin. All glass, plastic, and unpainted metal surfaces must be covered (fig. 194). Dark cloth is the most practical material to use. Light-colored cloth affords no concealment and is not to be used except in predominantly snow areas. If cloth is not available, freshly cut foliage or similar locally available material can be substituted (figs. 190 and 191). The insignia on the upper surface of the left wing, if a plane, and on the rear and sides of the fuselage of planes and helicopters must also be covered. An otherwise well-concealed aircraft may be

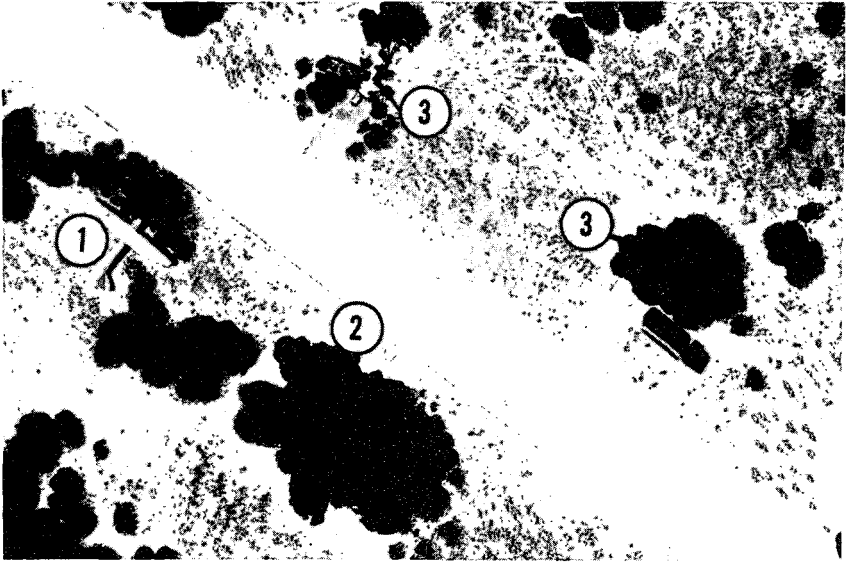

- 1 Aircraft has not been camouflaged, tracks have been concealed by brush
- 2 Parking area of completely concealed aircraft revealed by tracks
- 3 Tracks of aircraft and servicing vehicles reveal parking area of partially concealed aircraft

Figure 193. Parking areas revealed by lack of camouflage.



Figure 194. Covering shine and insignia on H-19 helicopter.

spotted from low-altitude observation by the color and shape of the insignia (figs. 194 and 195).

b. In order to conceal windshields, windows, propellers of planes, and helicopter rotor blades and other highly reflective areas which have not been camouflaged, covers should be used. These covers should be of a color that best matches the general camouflage scheme of the aircraft. Lightweight camouflage covers may be fabricated from standard camouflage materials.

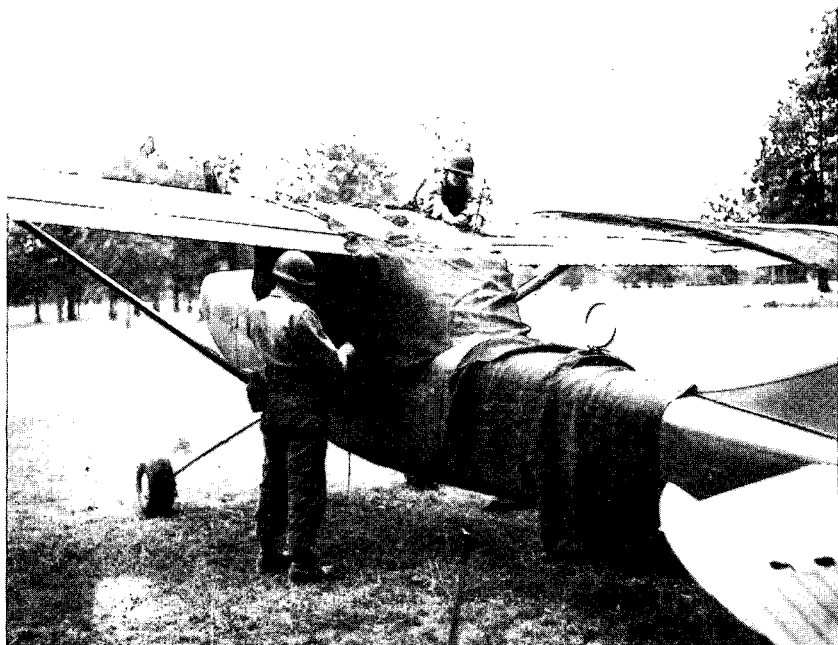

Figure 195. Covering shine and insignia.

107. Shadow Nets

Shadow nets placed on the ground, particularly under an aircraft, break its outline and distort its shadow even when it is completely in the open. The effectiveness of a net increases in proportion to the number of shadows or other dark areas. Shadow nets are camouflage nets garnished to appear to be a group of irregular dark patches. Garnishing should be 60 percent black and 40 percent olive drab. A 10-inch border of dark green garnishing is added in the temperate zone to blend the net with the terrain (fig. 196). If these materials are not available, dark cloth with holes torn in it can be used successfully. Dark patches can also be produced by burning rags, brush, or other debris to produce ashes or by pouring crankcase drainings or black paint on the ground. Nets or cloth have an advantage however

in that they can be reused. If helicopters are to land and take off from these nets or cloth, care must be taken to anchor the nets or cloth securely against the air turbulence caused by the rotor blades.

108. Umbrellas

Another technique of supplementary concealment in wooded areas is to suspend a series of overhead frames, or umbrellas, from wires strung between the trees. These umbrellas can be made of cut branches, trimmed and tied together with wire. Hung at varying heights,

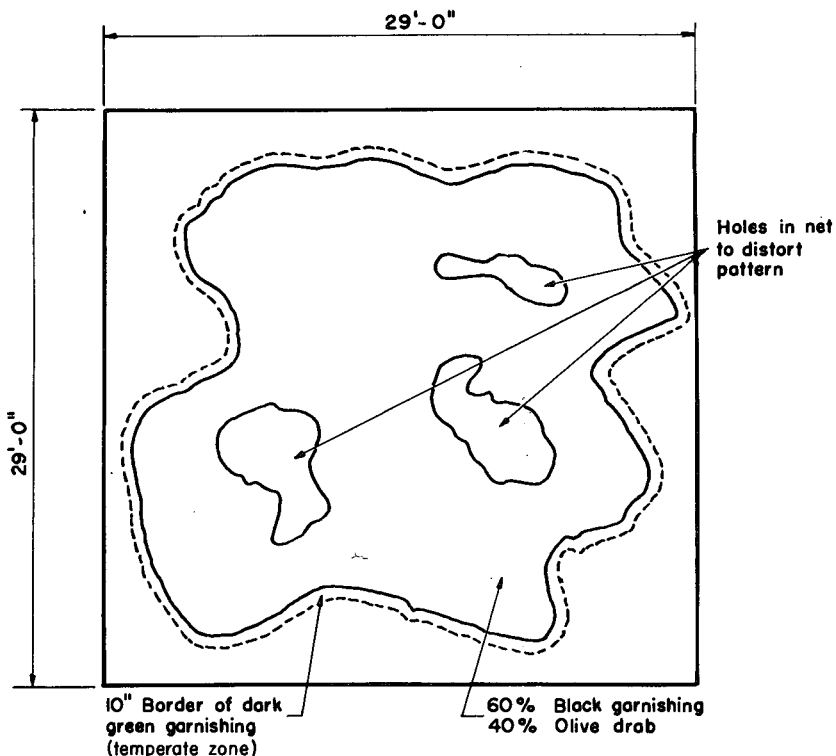

Figure 196. Typical shadow net.

above aircraft, the umbrellas simulate treetops (fig. 197). Fresh foliage is used for garnishing the frames and must be replaced as it withers. Umbrellas may also be garnished with other camouflage materials such as burlap, steel wool, glass fiber, and chicken feathers.

109. Hammock

A twine or wire net hammock hung between trees gives additional overhead protection in thinly wooded areas. Nets are to be garnished with artificial materials or with a combination of natural and artificial materials. Hammocks are effective only against vertical view (fig. 198).



Figure 197. Umbrella simulating treetops installed over H-2 helicopter.



Figure 198. Hammock above aircraft to give additional overhead cover.

110. Checklist for Effective Concealment of Aircraft

- a. Revealing signs of activity nearby are to be avoided.
- b. Shiny parts and brightly-colored insignia are to be covered.
- c. Shape is to be distorted by placing foliage at edges or corners.
- d. Aircraft are to be located, whenever possible, near shadow-casting trees or structures to facilitate concealment but landmarks or isolated features are to be avoided.
- e. Constant inspection and maintenance is performed to insure the effectiveness of the camouflage plan.
- f. Strict adherence to camouflage discipline is to be maintained at all times.

111. Camouflage Painting

a. *General.* Camouflage painting is one of several camouflage measures which should be taken to make army aircraft less visible to hostile observation. Proper camouflage painting will enable an aircraft to blend into its surroundings by distorting features, minimizing contrast with terrain coloration, and reducing the shine which results from high gloss finishes. It should be pointed out, however, that camouflage painting is only effective against observation when the terrain is in the background. Its ability to blend into this irregular terrain background provides an appreciable degree of concealment, not only against ground-to-ground and air-to-ground observation but against air-to-air observation from above as well. Camouflage painting is of little use to an aircraft silhouetted against the sky since the distinct outline of the aircraft stands out against the brightness of the sky. Thus camouflage painting against ground-to-air observation is of negligible value.

b. *Basic Camouflage Color.*

- (1) *General.* The principal step in the camouflage painting of aircraft is the painting of the exterior with a lusterless paint of the optimum color for the terrain over which the aircraft will operate. The paint used for this basic camouflage color will normally be emulsifiable camouflage paint, but gasoline-removable paint can be used if only a temporary coat is desired.
- (2) *Temperate and jungle areas.* The basic camouflage color recommended for use in temperate and jungle areas and other areas of heavy vegetation is olive drab.
- (3) *Desert areas.* Because of large variations in desert coloring, no single color can be used as the basic camouflage color in all desert areas. Sand, desert sand, earth yellow, earth red, or even mixtures of these may be better in certain areas.

Use should be made of the color that best matches the predominate color of the particular terrain over which the aircraft is to be used.

- (4) *Snow areas.* In partial snow areas where the terrain is not predominately snow covered or where there are snows of short duration, olive drab should be used as the basic camouflage color.
- (5) *Arctic areas.* In areas where the terrain is predominately snow covered such as winter arctic, or in partial snow areas where there is considerable snow for long periods of time, aircraft should be painted completely white.

c. Disruptive Pattern.

- (1) *General.* The basic camouflage color alone provides a high degree of concealment. In some situations, camouflage may be improved by the use of a disruptive pattern. The best pattern for general use consists of one or more large irregular areas of a second color to give the aircraft the appearance of being broken into unrelated portions. A disruptive pattern is effective only as long as it is discernible as a pattern. It is discerned because of the color and brightness contrasts involved. Greater contrasts permit detection of the pattern from greater distances. However, the allowable contrast in the pattern is limited by the contrasts in the surrounding terrain. Color or brightness contrasts which are not present in the terrain background cause the patterned item to become more conspicuous than if no pattern had been applied, and should not be used. Figures 199, 200, and 201 illustrate possible camouflage schemes. These are simply suggestions, however; no one set pattern should be followed because variation in the appearance of aircraft is desirable (fig. 202). The number of areas of application is largely dependent on the size of the aircraft. Each area should be large enough to disrupt the shape of the aircraft. Because small areas tend to blend into one color when viewed at a distance, intricate and multicolor patterns are not effective for aircraft camouflage. A disruptive pattern may be sprayed on, brushed on, or applied by any other method available.
- (2) *Temperate and jungle areas.* Black should be used for the disruptive pattern in temperate and jungle areas and in other heavily vegetated areas.
- (3) *Desert areas.* Ordinarily black should be used for the disruptive pattern in desert areas. However, in areas of very light shadows, olive drab should be used.

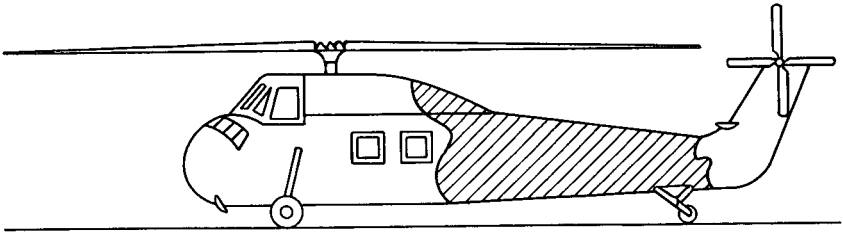
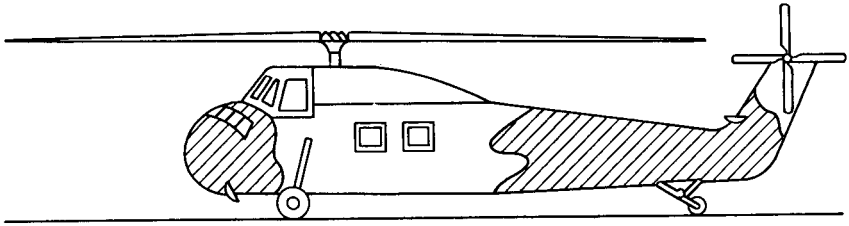

BASIC CAMOUFLAGE COLOR



DISRUPTIVE PATTERN

Figure 199. Pattern for H-34 helicopter.

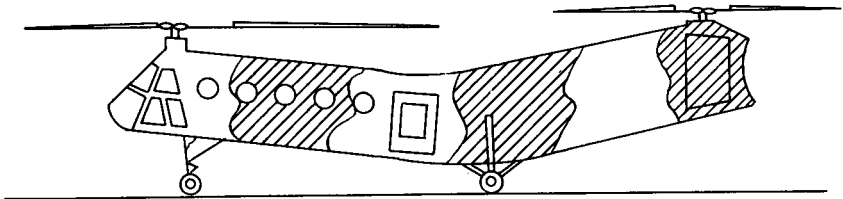
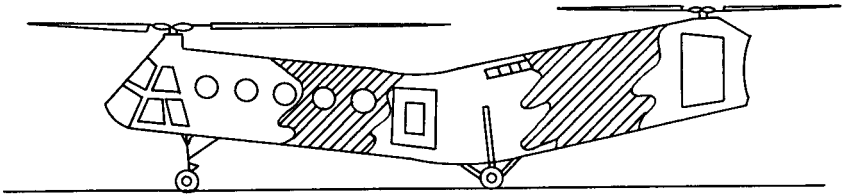

BASIC CAMOUFLAGE COLOR



DISRUPTIVE PATTERN

Figure 200. Pattern for H-21 helicopter.

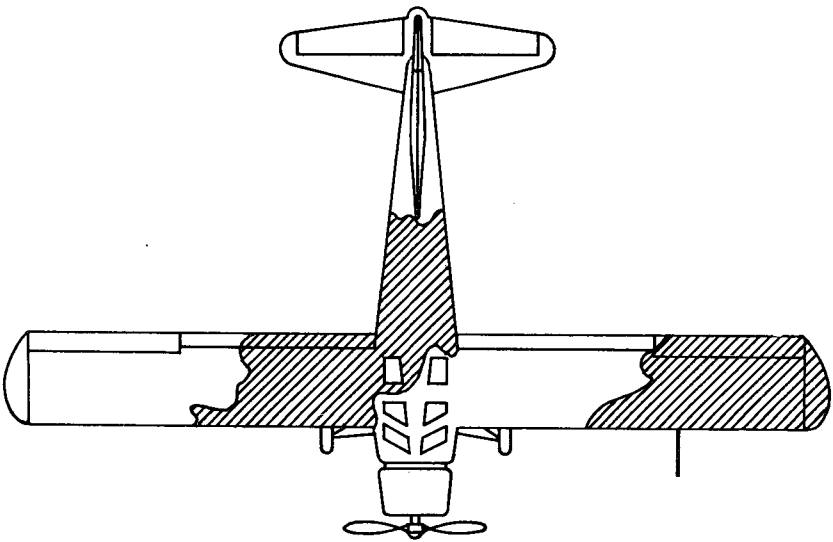
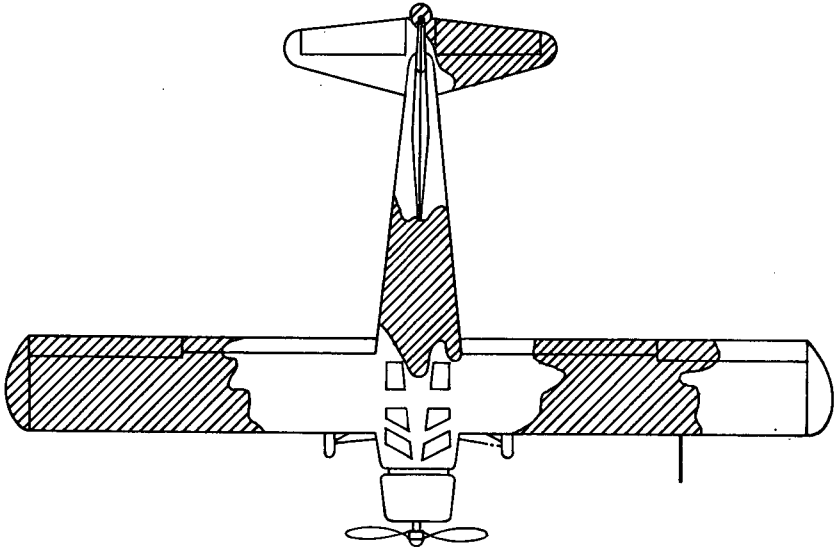



-  BASIC CAMOUFLAGE COLOR
-  DISRUPTIVE PATTERN

Figure 201. Pattern for L-20.



- 1 Standard
- 2 Solid color with cloth pattern
- 3 Interim pattern
- 4 Field pattern

Figure 202. Variations of disruptive patterns.

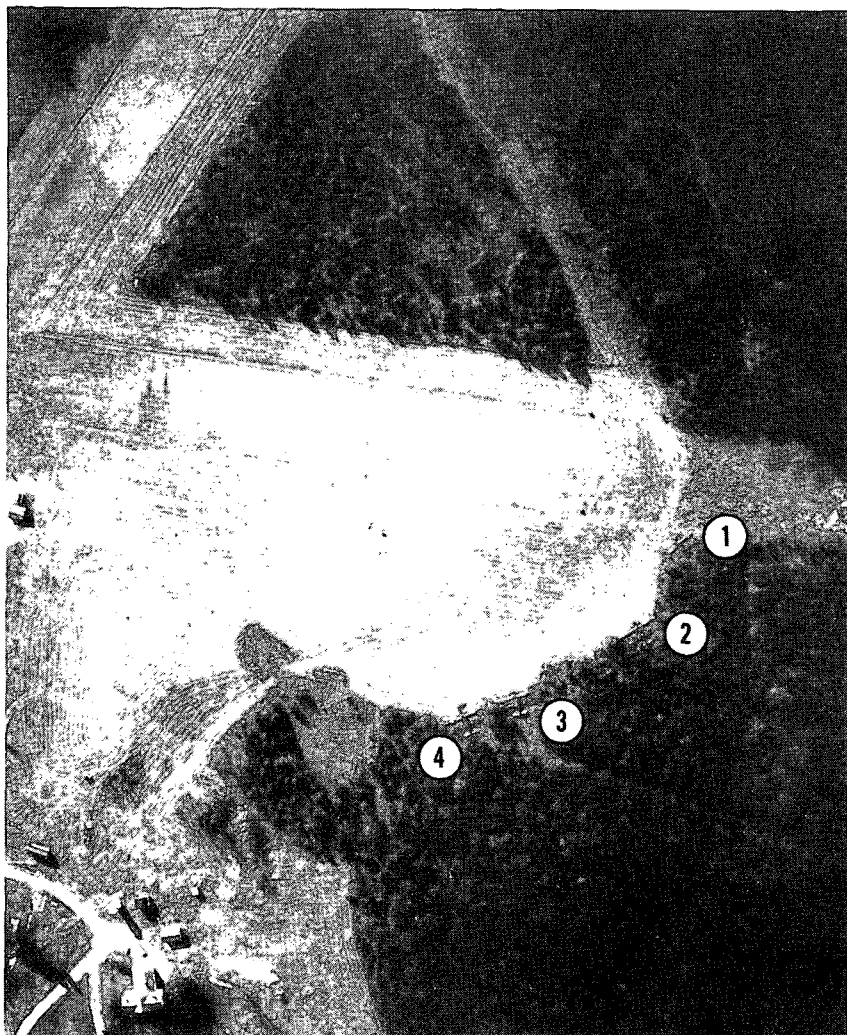
- (4) *Snow areas.* In partial snow areas where the terrain is not predominately snow covered or where there are snows of short duration, aircraft should remain olive drab without a disruptive pattern. In areas where the terrain is predominately snow covered or areas where there is considerable snow for long periods of time, aircraft should be painted completely white without a disruptive pattern.
- (5) *Alternate measures.* In parking areas where it is undesirable to use paint for the disruptive pattern, one or two large, irregular pieces of cloth in the disruptive pattern color can be used.

112. Undersurfaces and Antiglare Surfaces

Painting of undersurfaces has little or no value as a camouflage measure and it is recommended that these surfaces be left in the basic camouflage color of the aircraft. Light-colored undersurfaces do not conceal aircraft in flight except at very high altitudes, because the aircraft is silhouetted against the sky and appears as a dark object regardless of its color. All antiglare surfaces such as the top of the fuselage in front of the pilot's compartment and the inboard upper one-fourth of the engine nacelles forward of the leading edge of the wing on multiengine aircraft should be left in lusterless black.

113. Helicopter Rotor Blades

a. When other technical considerations are not prohibitive, helicopter rotor blades should be painted as follows:

- (1) Upper surface (except in Arctic areas)—olive drab.
- (2) Upper surface (Arctic areas)—white.
- (3) Under surface—black.

b. In cases where rotor blades have not been painted in the above manner, covers should be used.

114. Markings

For concealment on the ground it is essential that conspicuous identification marking such as "U. S. ARMY," the national insignia, and radio call numbers be hidden; otherwise, even the best of camouflage efforts might be defeated. These conspicuous markings are detrimental even to camouflage which may be complete in all other respects. In some instances it may be feasible to obliterate these markings by painting over them. In other cases it may be desirable to use markings intermittently. When markings cannot be removed, care should be taken that markings are well concealed with cloth or foliage or by other means. Simply replacing glossy yellow, white, red, or blue colors in markings with lusterless black will greatly reduce the conspicuousness of markings while still retaining them for identification purposes.

115. Limitations

It is important to understand that the camouflage painting of an aircraft, whether in pattern or solid color, affects only the color and to some degree the shine of the item. While these aspects of visibility are often the identifying features, it is more often true that the item's shape and shadow and the surrounding evidence of activity are so conspicuous as to permit detection regardless of color. The camouflage painting of aircraft is therefore to be regarded as a valuable asset, but only when used in conjunction with normal camouflage precautions. Full advantage of camouflage painting can only be gained if intelligent use is made of good siting, dispersion, track concealment, camouflage discipline, natural foliage, and artificial materials.

CHAPTER 12

FIELD EXPEDIENTS

116. General

Field expedients are used *only* after all means of natural concealment have been exhausted. Expedients such as nets, dummy shelters, and artificial garnishing add to the logistical problem. Therefore artificial materials are to be used only in areas of sparse vegetation or in areas where slashings of natural material will disclose the position. Field expedients discussed in the following paragraphs are adaptable to infantry weapons emplacements, antiaircraft artillery, field artillery, and vehicles:

a. Machinegun Flattop. The simple flattop for the machinegun with a ground fire mission requires no framework. Four posts about 2 feet long, No. 10 wire, and a garnished 15- by 15-foot twine net is all that is required. Corner posts are not driven; they rest on the ground and are held in place by strands of wire tightened by racking the guys. When wire is not available tent guyropes can be used. Corners of the net are slipped over the posts before racking. To dismantle the flattop the corner posts are knocked out, allowing the flattop to collapse. 1, figure 203, shows this type of flattop. The garnishing is thinned out toward the edges and the whole structure is as close to the ground as possible. The corner posts, 2, figure 203, are guyed to the ground. This type of flattop net can also be made with natural material such as vines and bushes interwoven.

b. Buggy Top. For a firing position, especially in terrain with natural foliage, the folding buggy top conceals the machinegun and affords a 360° field of fire for antiaircraft firing and 180° field of fire for ground missions. The buggy top can be folded back quickly allowing the gunners to engage aerial or ground targets. When opened for firing, the whole structure lies flat on the ground. Construction details are shown in figure 204. The frame can be made of pipe, saplings, or lumber. Hinges are made either of No. 10 wire, driftpins, pieces of scrap leather, or stock door hinges and stakes pivoted on pins made of wire. The net used is a 15- by 15-foot garnished twine net. Care must be taken to insure that the vegetation around the position is not disturbed by the buggy top when opened. If the vegetation does become damaged, steps must be taken immediately to restore it to its natural appearance. To com-

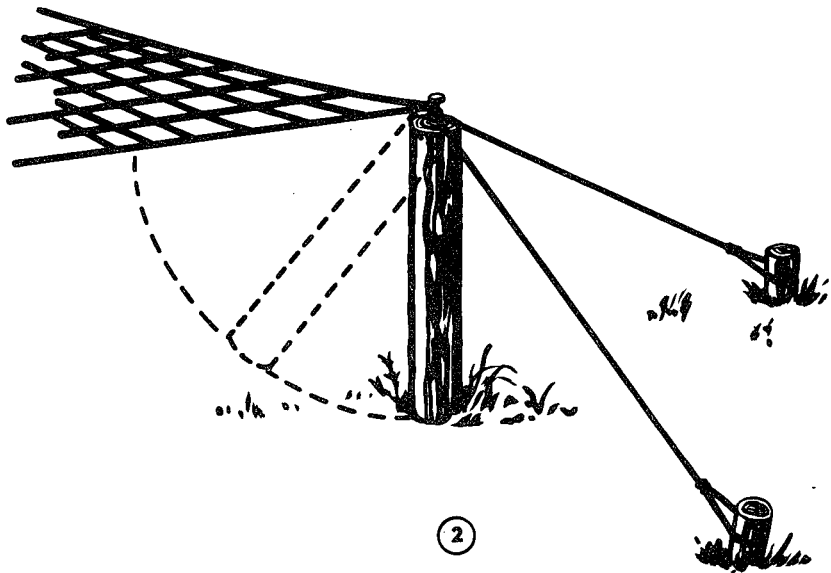
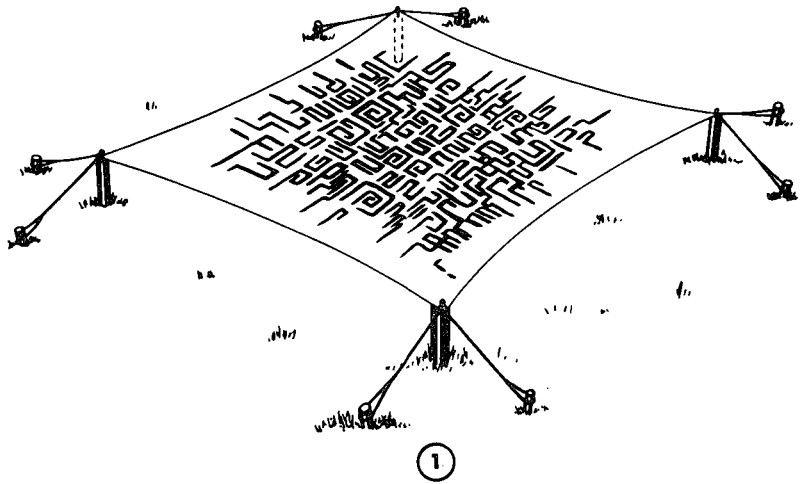

- 1 Pregarnished net on wire frame
- 2 Detail showing post guyed upright

Figure 203. Machinegun flattop.

plete concealment, small bushes can be placed irregularly around edges of net.

c. Swinging Flattop. For a firing position, especially in terrain with natural foliage, the swinging flattop conceals a machinegun and affords a 360° field of fire for antiaircraft and 180° for ground fire missions. The swinging flattop is a cantilever structure hinged on a post or stump of a tree at one corner. The swinging flattop pivots

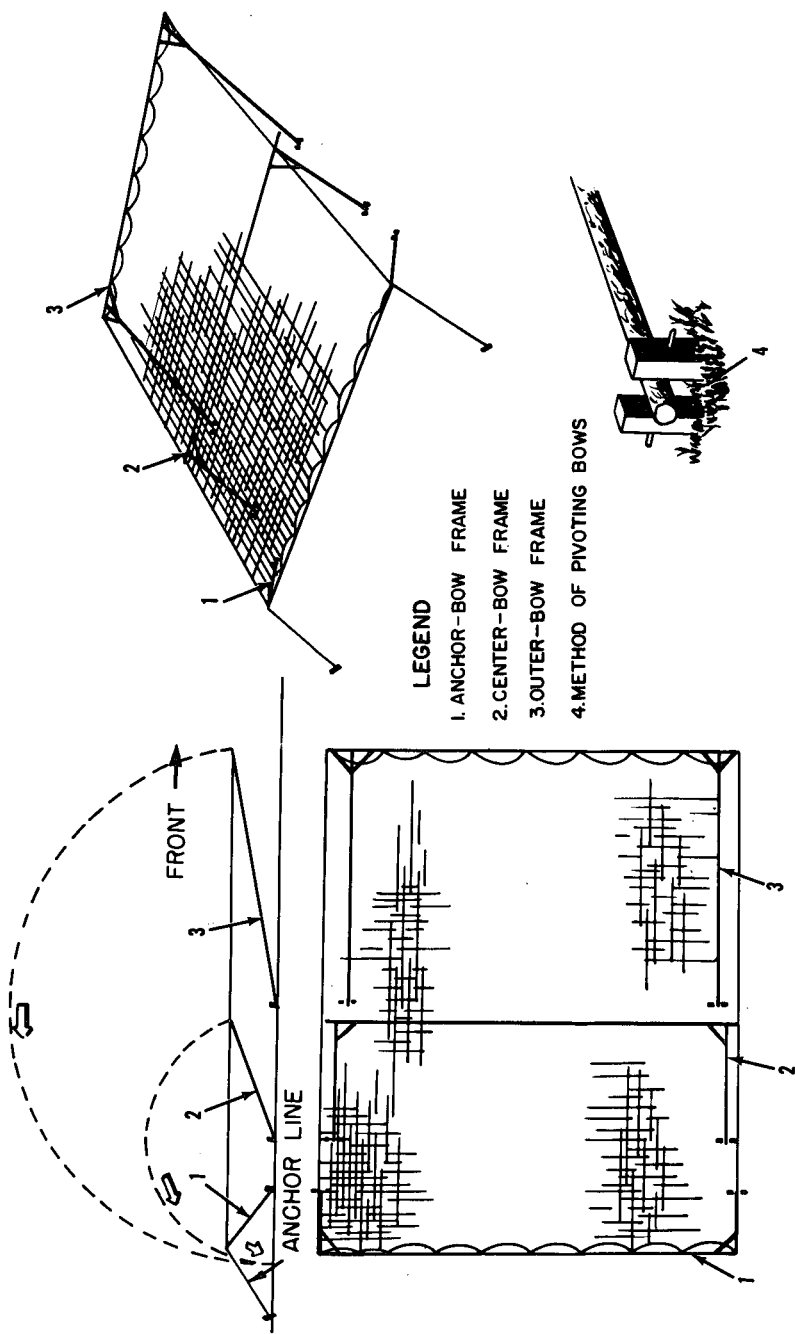

Figure 204. Buggy top construction detail.

on a simply constructed hinge, as illustrated in figure 205, and although the suspended span is easily pushed aside, construction demands a slight upward slope from hinge to outer edge to equalize the tension and pressure on the post; the whole structure should be as low to the surrounding vegetation as possible.

d. Sliding Cover. In some situations it will be advantageous to use a field expedient sliding cover over the emplacement (1 and 2, fig. 206). This is constructed from materials at hand and in a manner dictated by the nature of the materials used. The entire cover is designed to slide across the top of the emplacement to provide concealment.

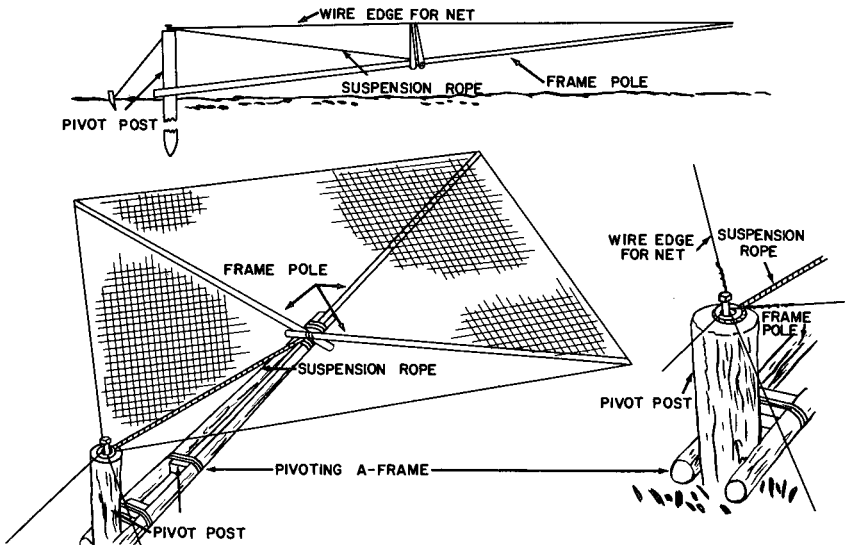
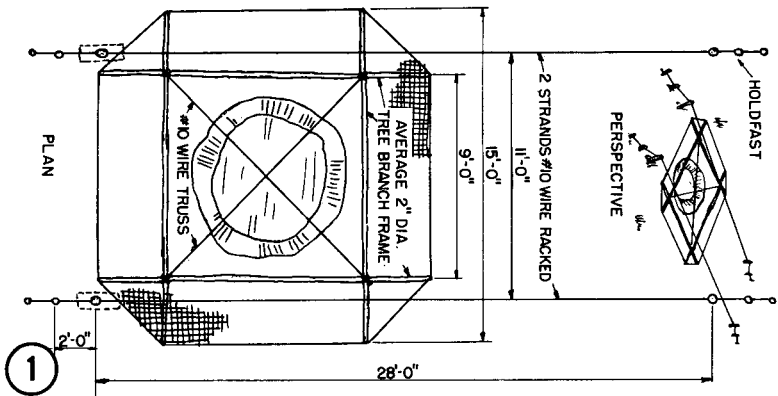
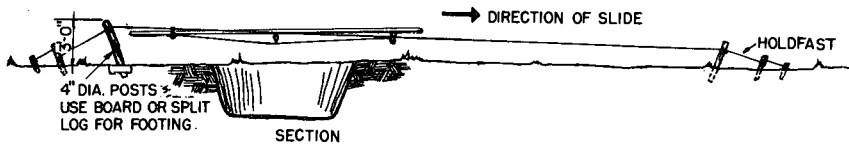

Figure 205. Swinging flattop construction.

e. Igloo. In deliberate positions, where the emplacement cannot be dug in and the terrain is broken with bushes and rocks, an igloo (fig. 207) is an effective quick-opening cover for mortars. Simply constructed, it is made of two sapling bows covered with two 15- x 15-foot garnished twine nets and wire hinges. A wire hook holds the top of the bows together when the igloo is closed. Lifting the hook permits igloo to open.

f. Hinged Fallaway Trees. One method of concealing a .50 caliber ground or antiaircraft firing position is illustrated in (1, 2, and 3, fig. 208). Trees are cut and hinged at their base and guyed to lean outward (1, fig. 208) so they fall away from the position when inside guys which are hooked to notched stakes (2 and 3, fig. 208) are released.



1 Sliding cover construction

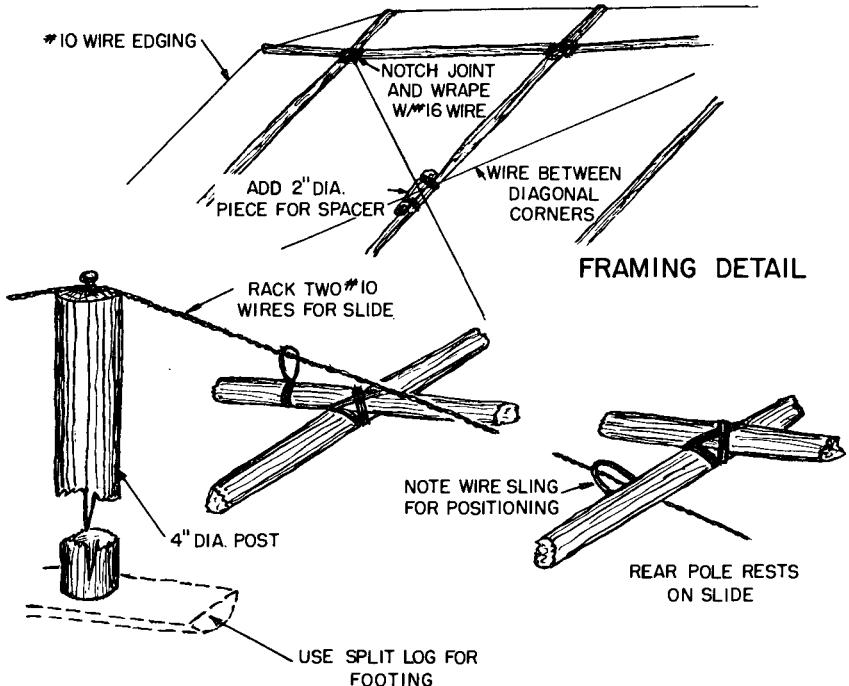

2 Suspension & slide detail

2 Suspension and slide detail

Figure 206. Sliding cover construction detail.

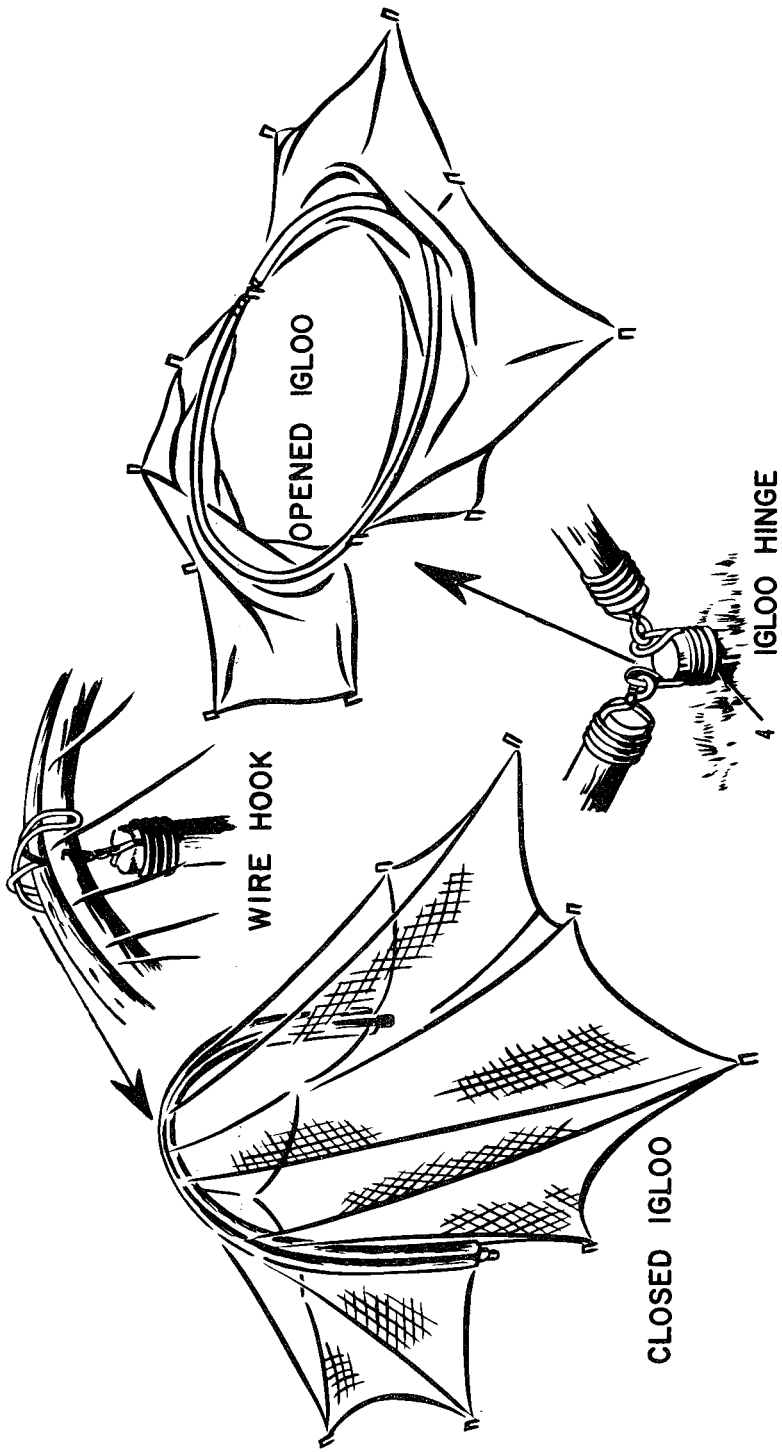
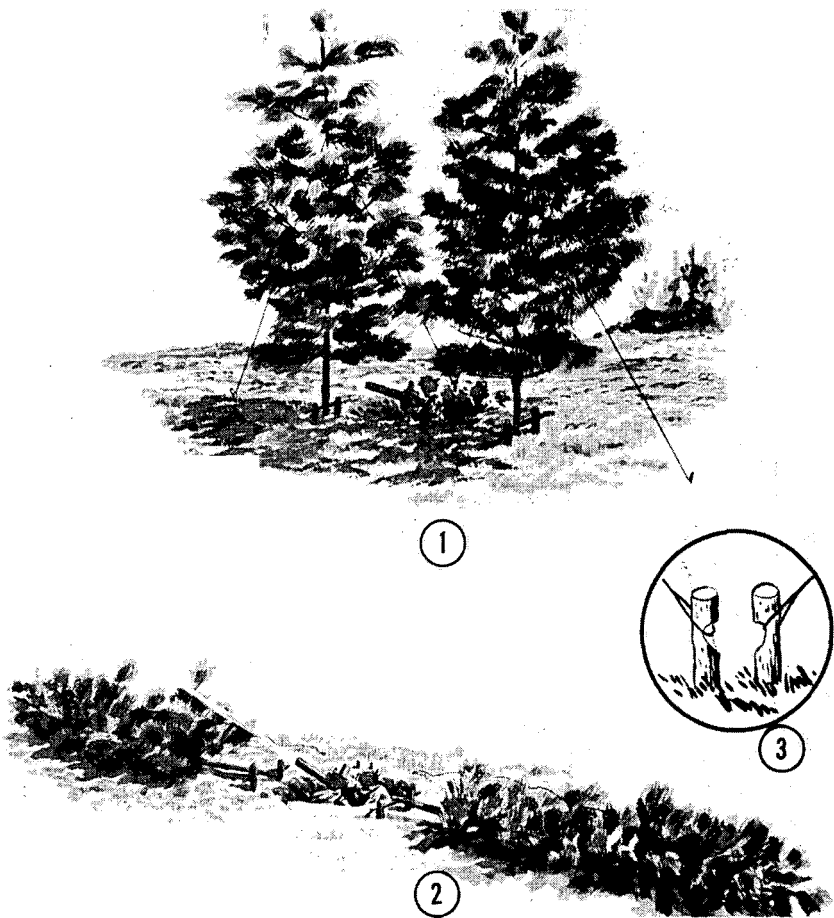

Figure 207. Construction of igloo.



- 1 Erected
- 2 Opened ready for firing
- 3 Notched stakes

Figure 208. Hinged fallaway trees.

g. Dummy House. The canvas house shown in 1 and 2, figure 209, can be constructed quickly and with materials normally available in the area. With this type of concealment of the emplacement an antiaircraft gun can fire at targets of opportunity and more likely remain undetected by the enemy.

h. Dummy Rocks. A dug-in antiaircraft gun can be effectively concealed by means of a rolling cover such as the one shown in figure 210.

i. Sliding Flattop for AA Gun. The sliding flattop, in two sections designed to move to opposite sides, enables an AA gun in a defensive dug-in position to fire quickly from a concealed emplacement. This flattop consists of two wooden frames, each 13 x 16 feet,

CANVAS HOUSE WITH COLLAPSIBLE ROOF FOR AA GUN

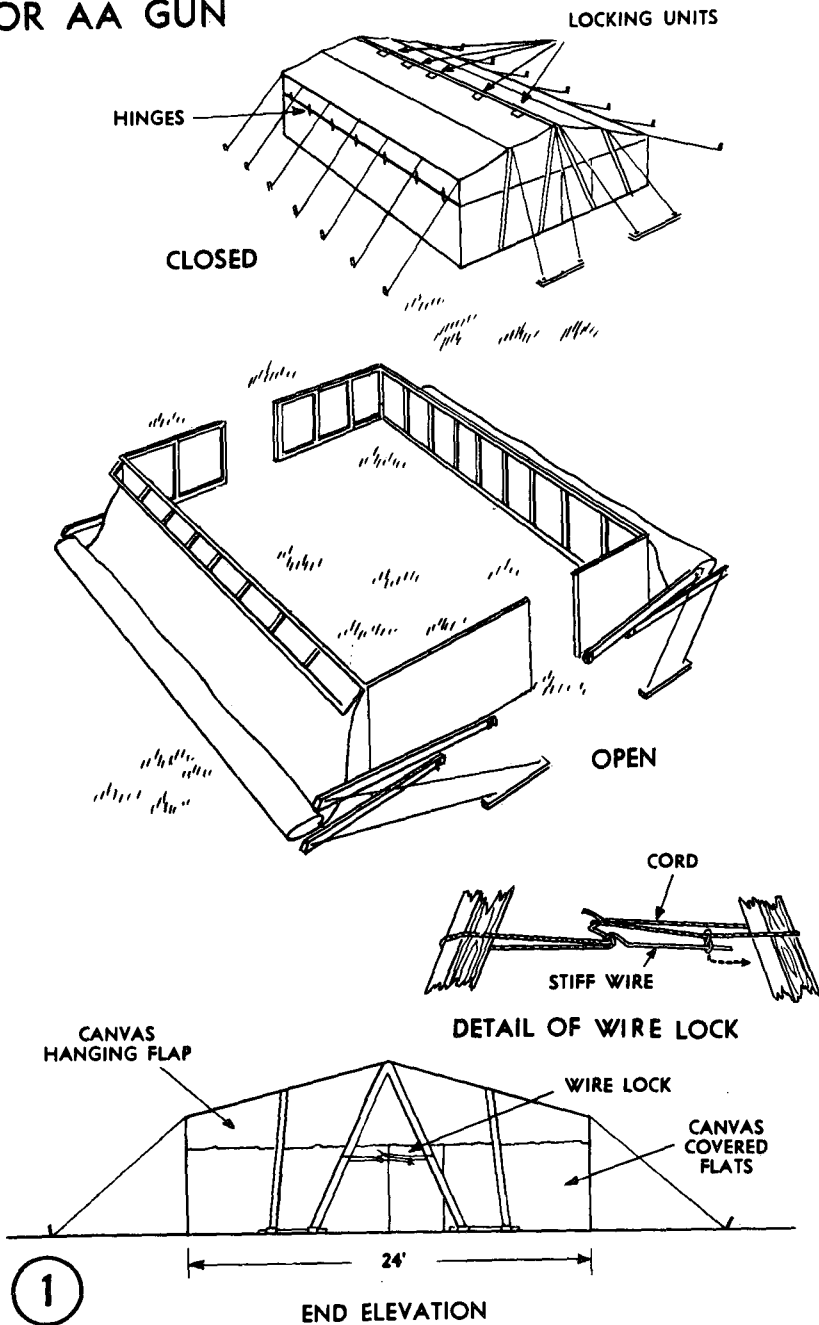

1 Elevation and isometric views

Figure 209. Canvas house with collapsible roof for AA gun.

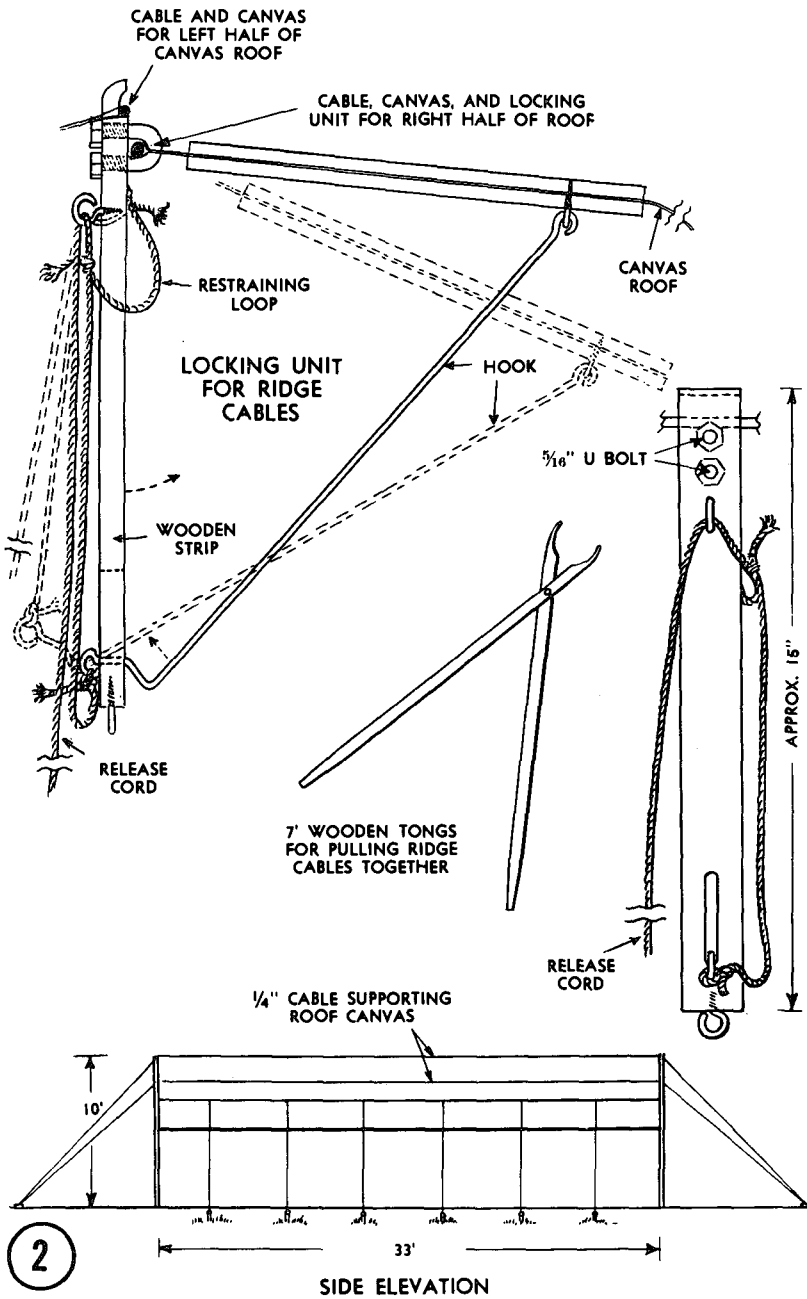

2 Details of cable, canvas, and locking unit

Figure 209—Continued.

ROLLING COVER OF DUMMY ROCKS FOR AA GUN

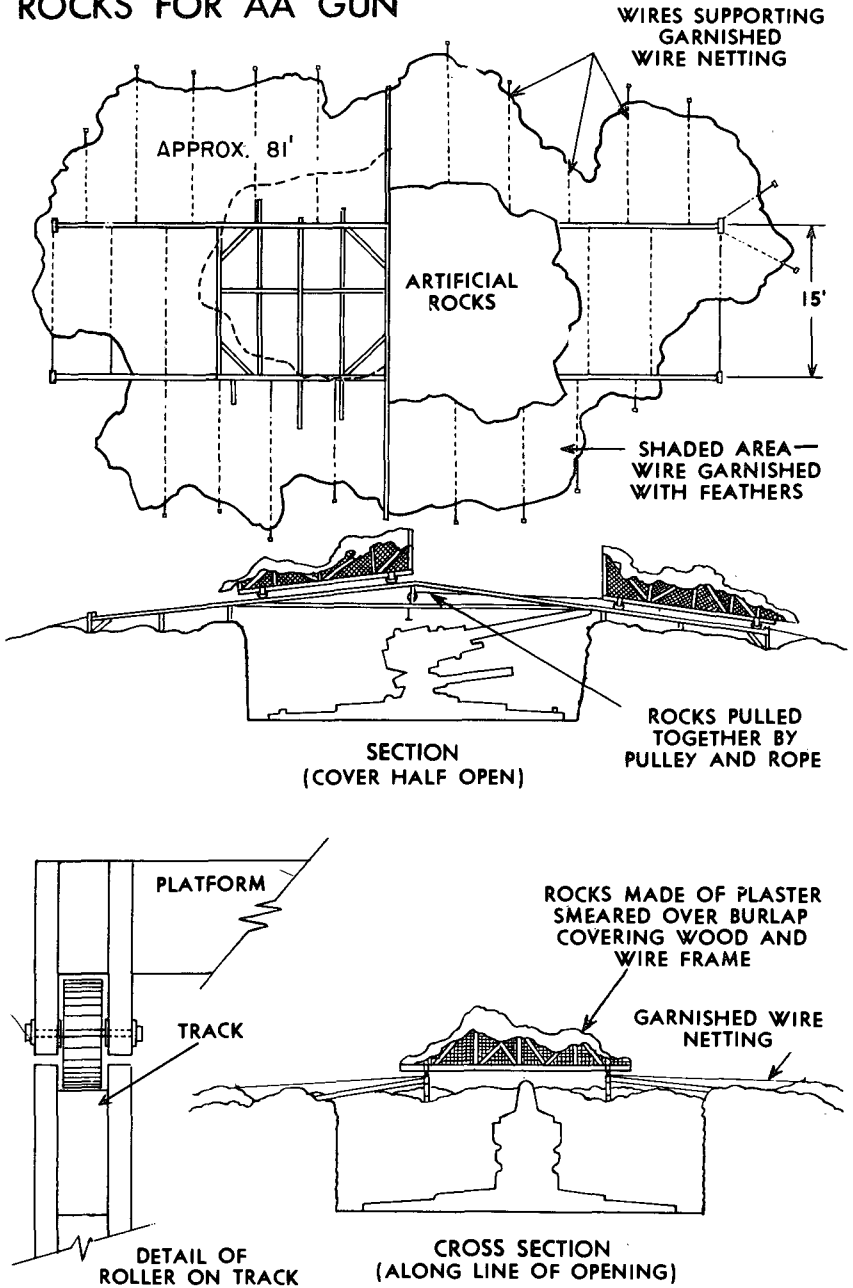

Figure 210. Rolling cover of dummy rocks for AA gun.

covered with garnished wire netting. Frames are supported on two wire cables, on which they slide. Cables are attached to pointed stakes, 1, figure 211, by strips of tin. Grooved end stakes, 2, figure 211, stop the frames when they are pushed open. Frames slide on tin-lined and greased blocks, 3, figure 211. Netting projects irregularly at sides of frame.

j. Umbrella Type for 3-Inch Mobile AA Gun. In a situation where a more permanent type of camouflage is desired the cover shown in 1 and 2, figure 212, can be constructed.

117. Drape Nets

a. Drape nets are the principal artificial expedient used for the camouflaging of vehicles or equipment. Drape nets are used when concealment by natural methods or materials cannot be obtained, or to supplement natural methods or materials in sparsely vegetated areas such as desert or barren areas, predominant snow areas, and thinly wooded areas (fig. 213). The drape nets vary in size, depending on the size of vehicle or piece of equipment to be covered. Drape nets are pregarnished and are a standard item of issue. For information on drape net sizes, see appendix II.

b. Drape nets are usually erected over the vehicles or equipment after it has been dispersed and sited in the parking area. However, if the length, width, and height of the vehicles or equipment to be covered is known, the nets may be erected in the parking area before the vehicles or equipment arrives in the area. In either method of erection the drape nets may remain erected while the vehicles or equipment are being used to support the unit mission (fig. 214).

118. Erection Procedures

a. The erection procedures described and illustrated in this paragraph can be used for all types of vehicles or equipment. The vehicles were sited for clear and concise illustrations of erection procedures. The ideal place to site the net in this type terrain is shown in figure 213.

b. The vehicle should be sited to eliminate as much shine and shadow as possible. To eliminate the remaining shine the windshield, lights, and reflectors are covered (fig. 215). Shine of the vehicle is covered before net is erected over the vehicle or immediately after the vehicle, being used, is parked under the net.

c. The drape net is placed on top of the vehicle and unfolded diagonally to the long axis of the vehicle as indicated in figure 216 or if the vehicle is in operation, the net is unfolded so the net will be diagonal to the long axis of the vehicle when parked under the net (fig. 217).

SLIDING FLAT-TOP FOR AA GUN

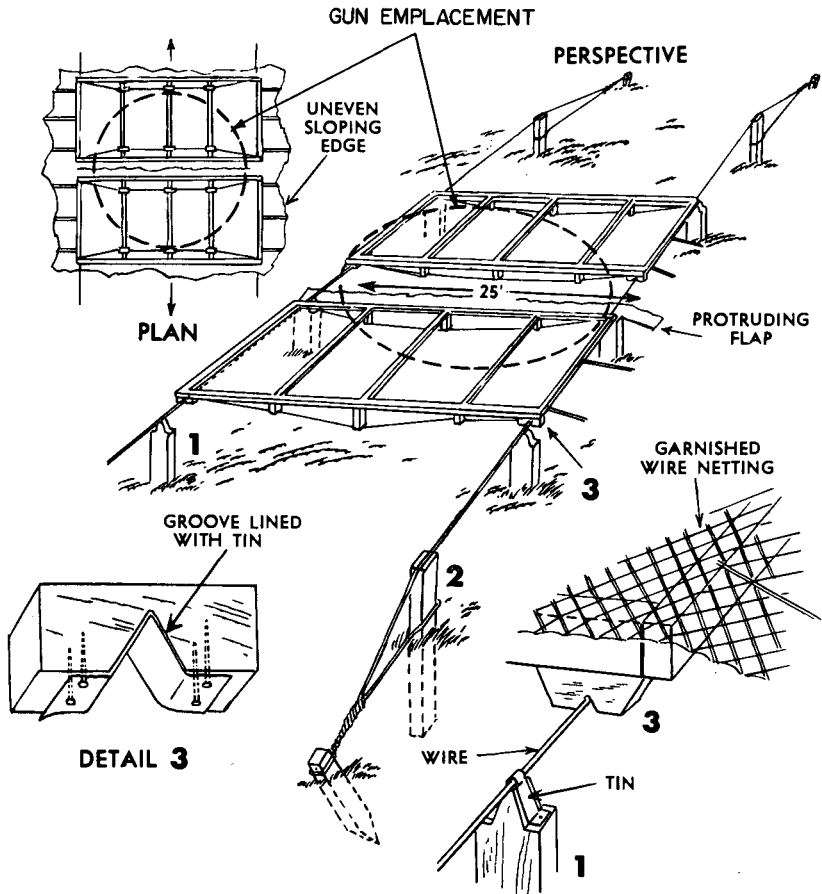

This flat-top consists of two wooden frames, each 13 by 16 feet, covered with garnished wire netting. Frames are supported on two wire cables, on which they slide. Cables are attached to pointed stakes, **1**, by strips of tin. Grooved end stakes, **2**, stop the frames when they are pushed open. Frames slide on tin-lined and greased blocks, **3**. Netting projects irregularly at sides of frames.

- 1 Pointed stakes
- 2 Grooved end stake
- 3 Tin-lined greased blocks

Figure 211. Sliding flattop for AA gun.

UMBRELLA-TYPE COVER FOR 3-INCH MOBILE AA GUN

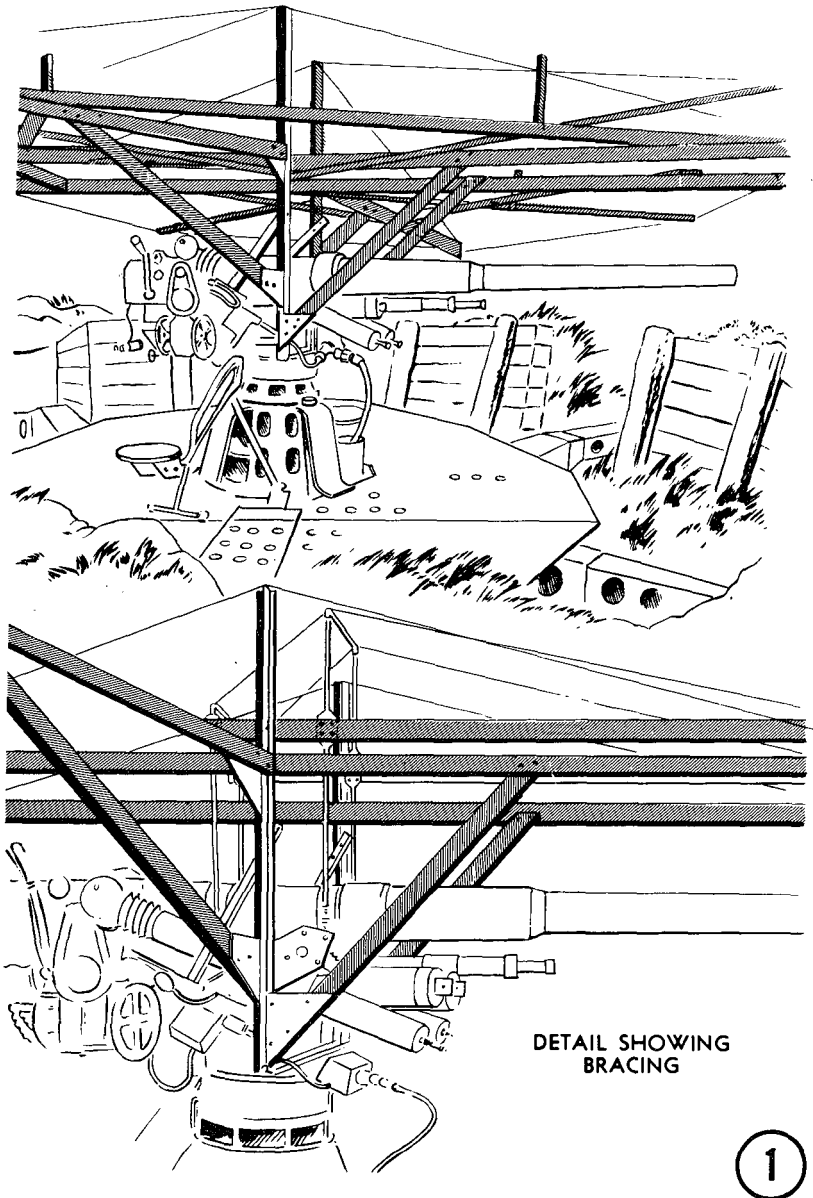

DETAIL SHOWING
BRACING

1

1 Plan and elevation

Figure 212. Umbrella type cover for 3-inch mobile AA gun.

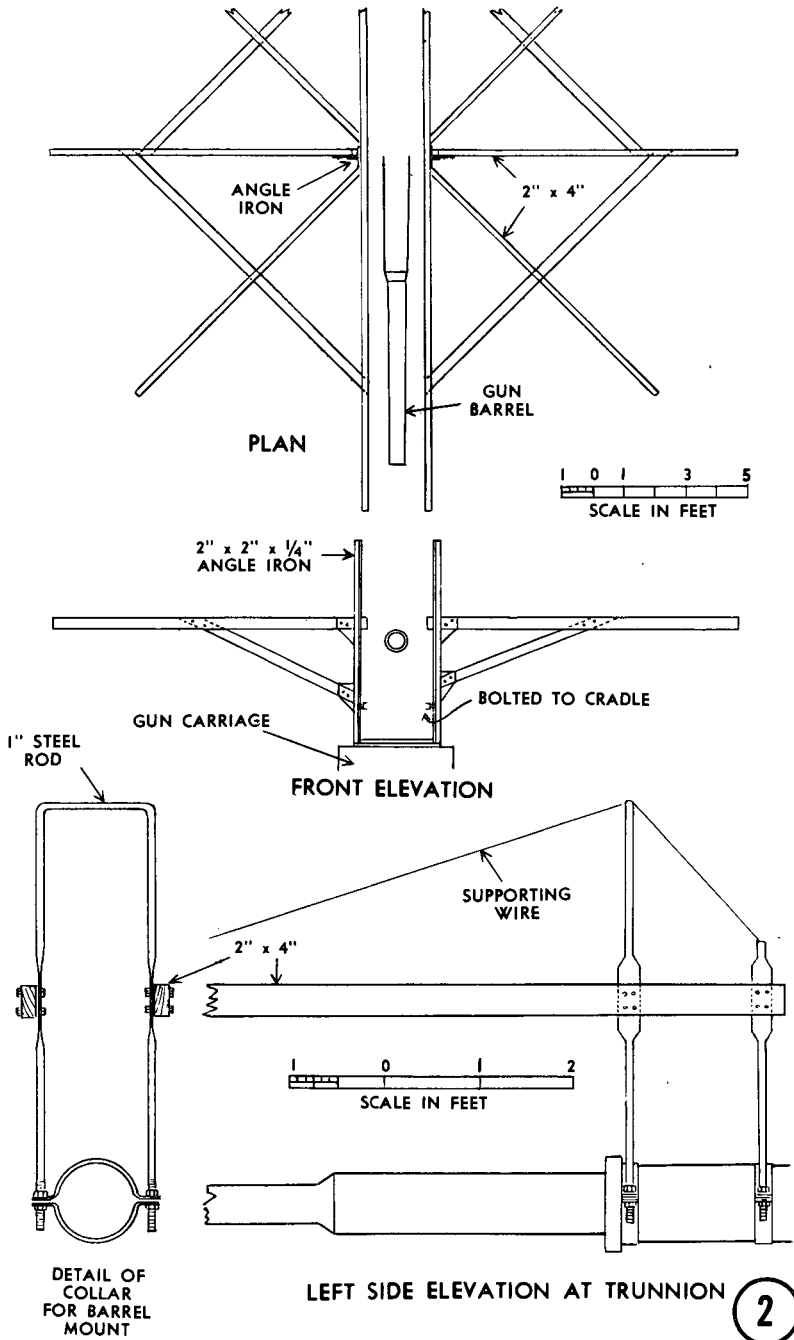

2 Detail showing bracing

Figure 212—Continued.



Figure 213. Drape net erected over vehicle in wooded area.

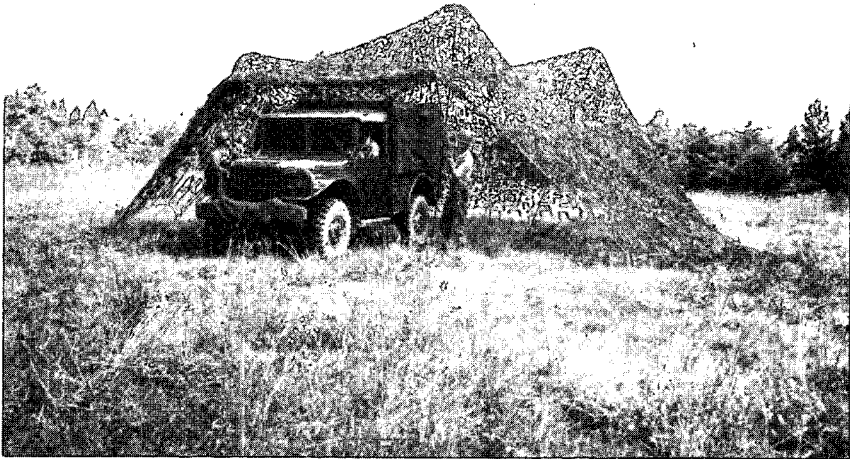

Figure 214. One edge of drape net raised for departing vehicle.



Figure 215. Crew covering windshield, lights, and reflectors.



Figure 216. Drape net unfolded diagonally over vehicle.



Figure 217. Unfolding drape net on the ground.

d. The drape net is unrolled and the corners are extended (1, fig. 218). Corney guy ropes are now extended, stakes driven, and guy ropes looped over stakes as indicated in 2, figure 218. Similar steps are followed in the erection of a drape net without vehicle in place (1 and 2, fig. 219).

e. The drape net should be raised to a minimum of 18 inches above any part of the vehicle with support poles, made from saplings, as indicated in figure 220. To prevent the saplings from cutting the net, the ends of the saplings are padded with dark cloth.

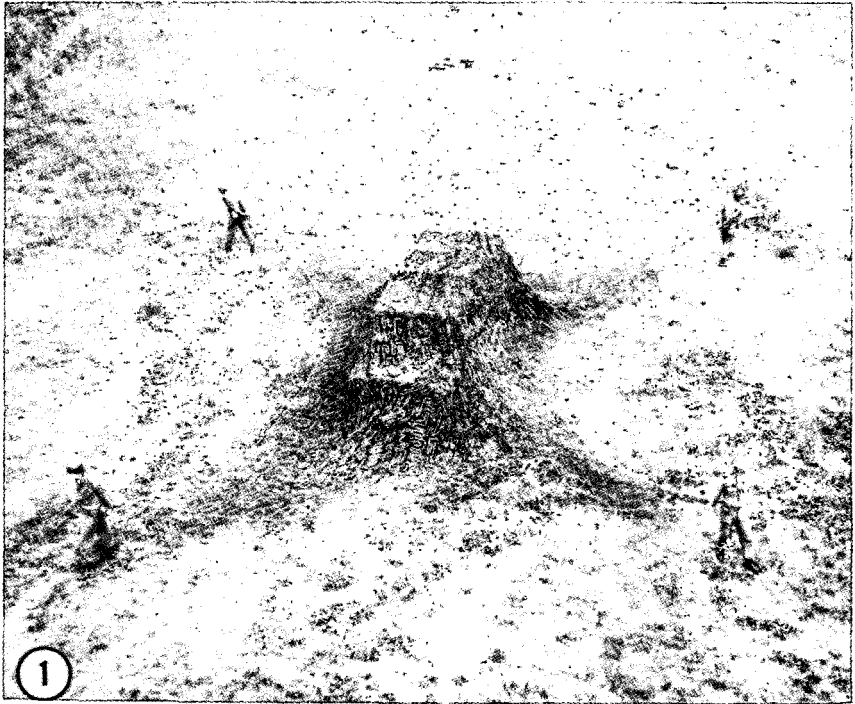

1 Extending corners of drape net

Figure 218. Extending and staking corners of drape net with vehicle in place.

f. Intermediate stakes should now be located and driven at approximately 12-foot intervals along the edges of the net as indicated in figure 221 for both methods of erection. Guy ropes should now be looped over stakes and adjusted.

g. The tracks of the vehicle should now be brushed out or covered as illustrated in figure 111.

h. Net should now be trimmed by placing support poles to disrupt any straight line effect and to insure that net gradually slopes to ground and presents a low silhouette.

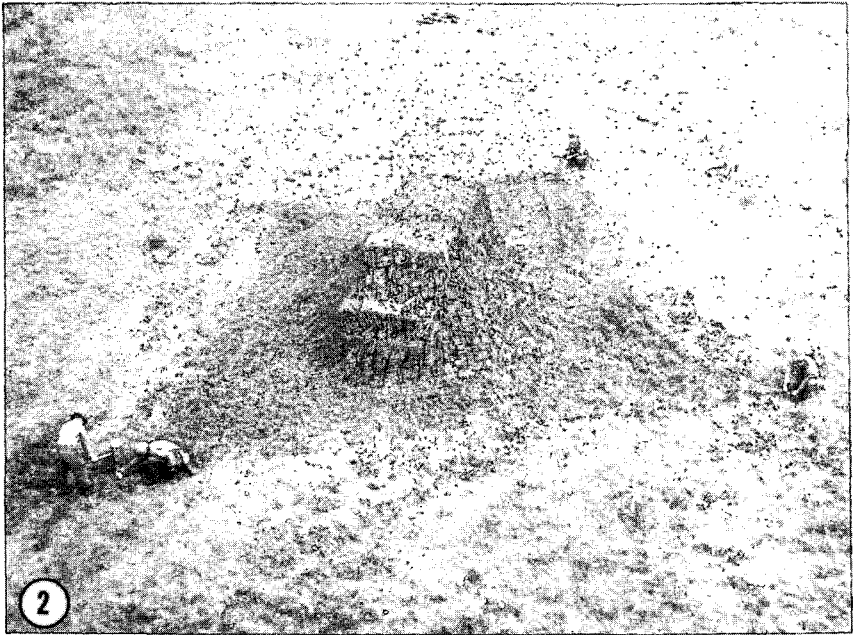

2 Staking corners of drape net

Figure 218—Continued.



1 Extending corners of drape net

Figure 219. Extending and staking corners of drape net without vehicle.



2 Staking corners of drape net

Figure 219—Continued.

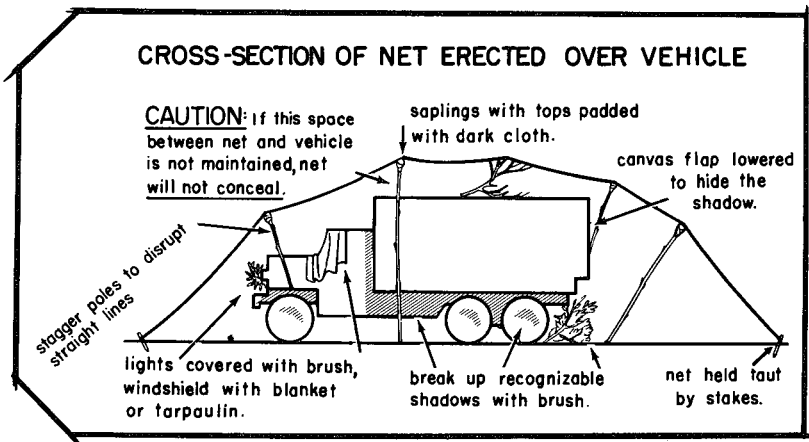

Figure 220. Cross section of drape net erected over vehicle.

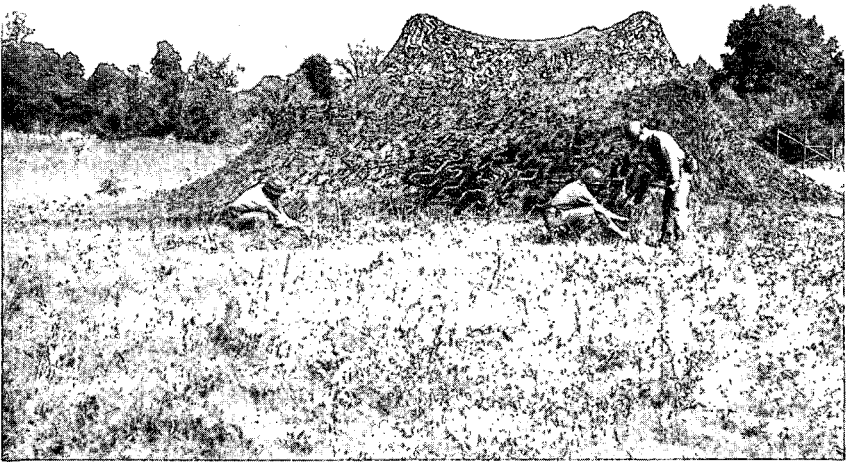

Figure 221. Placing and driving intermediate stakes along the edges of the drape net.

APPENDIX I

REFERENCES

- DA Pam 108-1 Index of Army Motion Pictures, Film Strips, Slides, and Phono-Recordings.
- DA Pam 310-5 Military Publication—Index of Graphic Training Aids and Devices.
- DA Pam 310-Series Military Publications (as applicable).
- AR 220-70 Companies General Provisions.
- AR 320-5 Dictionary of United States Army Terms.
- AR 320-50 Authorized Abbreviations.
- FM 3-5 Tactics and Techniques of Chemical, Biological, and Radiological Warfare.
- FM 3-50 Chemical Smoke Generator Battalion and Chemical Smoke Generator Company.
- FM 5-5 Engineer Troop Units.
- FM 5-6 Operations of Engineer Troop Units.
- FM 5-15 Field Fortifications.
- FM 5-22 Camouflage Materials.
- FM 5-23 Field Decoy Installations.
- FM 5-34 Engineer Field Data.
- FM 5-35 Engineer's Reference and Logistical Data.
- FM 21-5 Military Training.
- FM 21-6 Techniques of Military Instruction.
- FM 21-30 Military Symbols.
- FM 30-5 Combat Intelligence.
- FM 31-70 Basic Arctic Manual.
- SM 5-4-1080-SO9 Camouflage Net Set, Field Artillery.
- TM 3-240 Field Behavior of Chemical Agents.
- TM 5-250 Roads and Airfields.
- TM 5-251 Army Airfields and Heliports.
- TM 30-245 Photographic Interpretation Handbook.
- TM 30-246 Tactical Interpretation of Air Photos.
- GTA 5-1 Concealment and Camouflage.
- A Subj Sec 17-3 Scouting and Patrolling.

APPENDIX II

TECHNICAL INFORMATION AND DATA ON INDIVIDUAL DRAPE NETS AND DRAPE NETS SETS

Section I. INDIVIDUAL DRAPE NETS

1. General

a. This section provides a guide in determining the proper size and number of individual drape nets necessary to camouflage standard military equipment. The drape nets described are standard items of equipment and are stocked in the following sizes:

- (1) 22 ft. x 22 ft.
- (2) 29 ft. x 29 ft.
- (3) 36 ft. x 44 ft.
- (4) 45 ft. x 45 ft.

b. These nets are issued in two garnishing color blends, the all-seasonal and desert.

2. Determination of Net Sizes

In determining net sizes for military equipment in the field the rule of thumb formula described in *a*, *b*, and *c* below, should be followed.

a. Width of Net. To obtain the width of a net, add width of the equipment to twice the height of the equipment, and then add 5 feet. The purpose of the 5 feet is to gain enough net surface to keep the net at least 1½ feet above the equipment on all sides.

b. Length of Net. To obtain the length of a net, add the length of the equipment to twice the height of the equipment, and then add an additional allowance of 5 feet for the same purpose outlined in the preceding paragraph.

c. Final Analysis. If the net size computed from this rule of thumb formula falls between two standard issue net sizes, use the larger size. In some cases two standard nets must be jointed to obtain the proper sized net. Table I lists standard items of equipment and the size and number of drape nets required to conceal equipment. If the particular item of equipment is not listed in this table the formula outlined in *a* and *b* above, should be used.

Table I. Individual Drape Nets

Type of vehicle or equipment	Size individual drape nets			
	22 ft. x 22 ft.	29 ft. x 29 ft.	36 ft. x 44 ft.	45 ft. x 45 ft.
	No. required per vehicle or equipment			
Ambulance, ¾ ton.....		1		
Ambulance, metro.....			1	
Ambulance, 1½ ton, 12 litter.....				1
Asph and soil agg mixing plant 25 ton per hr:				
Unit 1.....			1	
Unit 2.....			1	
Unit 3.....			1	
Unit 4.....		1		
Asphalt plant 10-30 ton per hr:				
Unit 1.....			1	
Unit 2.....			1	
Auger, earth, skid-mtd.....			1	
Bulldozer, tank mtd, M1A1, M2, and M3.....				1
Bus 4 x 2.....			1	
Bus, amb. 18 litter 4 x 2.....			2	
Car, armored, light, M8-M20.....			1	
Car, halftrack, M2A1.....			1	
Carriage, half track, M16, M19A1, T106, M41, full track.....			1	
Carriage, motor, M15A1, M18, M36B1, 105-mm how M7, 240-mm how M1.....				1
Carriage, motor, 90-mm gun, M36, M36B2, 155-mm gun M40, 8 in. how M43.....			2	
Carrier, halftrack, M3, M3A1.....			1	
Carrier, cargo, M29, M29C, T46E1.....			1	
Carrier, 81-mm mortar, halftrack M4, M4A1, M21.....			1	
Carrier, universal T16.....			1	
Carrier, personnel, full track, M59.....				1
Crane, trk mtd, and tractor mtd.....			2	
Crane, trk mtd, M2.....				2
Conveyor belt, 24 ft x 57 ft.....	3			
Crushing & screening plant, 25 cu yd per hr:				
Unit 1.....		2		
Unit 2.....			2	
Distribution, bituminous, trailer mtd & water, trk mtd.....			1	
Dolly, trailer M363, M364, M197, 8-ton and 10-ton.....		1		
Dryer, aggregate, 80 to 150 ton per hr, trailer mtd.....			2	
Finisher, asphalt crawler mtd, 12-ton.....		1		
Generator and charging plant, trl mtd, hydrogen and carbon dioxide.....				1
Generator and charging plant semitrailer mtd, oxygen, nitrogen, and acetylene gas.....			2	
Gradation, control unit, trl mtd.....			1	
Grader, road, motorized.....			1	
Gun, machine, .30-cal and .50-cal.....	1			

Table I. Individual Drape Nets—Continued

Type of vehicle or equipment	Size individual drape nets			
	22 ft. x 22 ft.	29 ft. x 29 ft.	36 ft. x 44 ft.	45 ft. x 45 ft.
	No. required per vehicle or equipment			
Gun, twin 40, T141			1	
Gun, 155-mm T97			2	
Hearse, ¼-ton 4 x 2			1	
Heater, asphalt, trailer mtd		1		
Howitzer, 155-mm, T99E1			2	
Kettle, asphalt repair, trailer mtd		1		
Landing vehicle tracked MK4, LVT (4)				1
Landing vehicle MK4, LVT (a) (4)			2	
MK5, LVT (a) (5)			2	
Loader, shovel, tractor mtd ½ cu. yd	1			
Loader, aggregate crawler mtd			1	
Mixer, rotary trl mtd power takeoff	1			
Mixer, rotary gas engine driven, trl mtd		1		
Mixer, asphalt diesel engine driven tral mtd			2	
Mortar, 60-mm, 81 mm, and chemical 4.2 in	1			
Plow, snow, trk mtd 7½-ton, 4 x 4			1	
Pump, Water trl mtd and asphalt, trl mtd		1		
Reproduction equip. 22 in. x 29 in. motorized trk, 4 ton, 6 x 6, van type body				1
Roller, road, gas driven, or towed, 2 axle 5- to 8-ton 13 w		1		
Roller, road, gas or diesel driven 3 w, 3 axle 9- to 14-ton			1	
Scraper, road, towed type 1½ cu yd		1		
3½ cu. yd. and 6 cu. yd		2		
8 cu. yd. or 12 cu. yd.			1	
Scraper, road, motorized, 12 cu. yd				1
Semitrailer, stake and platform, 3½-ton to 5-ton, 2w			1	
Semitrailer, stake and platform and cargo 6-ton			2	
Semitrailer, van type, 3-ton 2w to 15-ton 2w			2	
Semitrailer 16-ton 2w to 25-ton 2w				1
Semitrailer, transporter 40-ton-45-ton 2-wheel				2
Semitrailer, w/dolly 20-ton, low bed		2		
Shop equip gen repair trk 2½-ton 6 x 6			1	
Shop, mobile set No. 1, 12-ton				1
Sled, cargo, 1 ton M1, M1A1, M14 and M14A1	1			
Station wagon 7 & 8 passenger 4 x 2		1		
Sweeper, rotary broom, 3w trl mtd	1			
Tank, asphalt steel, trailer mtd, 1,500-gal			1	
Tank, asphalt steel, trk mtd 800-gal, 4-ton, 6 x 6			1	
Tank, water, steel semitrailer mtd			1	
Tank, light, M24			1	
Tank, 76-mm gun, M4A1, M4A3, M26, M26A1, M46, & M46A1 and 90-mm gun M47			2	
Tank, medium, 75-mm gun, M4A1, M4A3				1

Table I. Individual Drape Nets—Continued

Type of vehicle or equipment	Size individual drape nets			
	22 ft. x 22 ft.	29 ft. x 29 ft.	36 ft. x 44 ft.	45 ft. x 45 ft.
	No. required per vehicle or equipment			
Tank, medium, 105-mm how M4, & M4A3				1
Tank, medium, M45				1
Tractor, crawler type, 20 DBHP	1			
Tractor, wheel type	1			
Tractor, high-speed 7-ton		1		
Tractor, crawler type, 36 to 45 DBHP		1		
Tractor, high-speed, 12- to 18-ton			1	
Tractor, crawler type, 36 to 45 DBHP w/angle dozer			1	
Tractor, crawler type, 24,100 to 32,000 lb. DBP			1	
Tractor, earth moving, crawler, 46 to 140 DBHP No. 1			1	
Tractor, wheel, pneumatic, 3-wheel 14,025 to 20,000 DBH			1	
Tractor, high speed 28-ton and 38-ton				1
Tractor, cargo M8E2				1
Trailer, ¼- to ½-ton 2w, Amm M10, oxygen servicing type E1 and E2 mount N-20	1			
Trailer, cargo, ¾-ton, 2w, M101		1		
Trailer, cargo, 1-ton, 2-wheel		1		
Trailer, cargo, 1½-ton, 2w, M104		1		
Trailer, tire repair, 1-ton, 2w, load A & B M-25		1		
Trailer, water tank, 1-ton, 1½-ton 2w		1		
Trailer, 1¼-ton, 2w, ARC welder		1		
Trailer, 1½-ton, 2w, 2-ton to 3½-ton, 2w & 4w		1		
Trailer, 2½-ton, 2w cargo amphibian		1		
Trailer, 2½-ton, 3w, M5		1		
Trailer, 5-ton, 2w, cable splicer		1		
Trailer, 6-ton, cargo tracked, (ATHEY), model BT-898-1		1		
Trailer, 7- to 14-ton special tandem (4DT)		1		
Trailer, chemical handling, M2		1		
Trailer, clothing and textile repair 2w		1		
Trailer, fire pumper 2w, 500 gpm		1		
Trailer, laundry mobile, 2w, Nos. 1 & 2		1		
Trailer, MT, M17		1		
Trailer, 2w shoe repair		1		
Trailer, shower bath		1		
Trailer, 1-ton, 2w, antenna, mount U 141t, 2-horse van			1	
Trailer, 1½-ton, 2w cargo and lubricator			1	
Trailer, 2-ton, 2w director			1	
Trailer, 2-ton 4w, w/smoke generator M7			1	
Trailer, director, 2t, 4w, M13, M14, & M22			1	
Trailer, bomb, 2½t, 3w, M5			1	

Table I. Individual Drape Nets—Continued

Type of vehicle or equipment	Size individual drape nets			
	22 ft. x 22 ft.	29 ft. x 29 ft.	36 ft. x 44 ft.	45 ft. x 45 ft.
	No. required per vehicle or equipment			
Trailer, clamshell, 3t, 2w, M16			1	
Trailer, ammunition, 4t, 2w, M21			1	
Trailer, 6t, cargo tracked (model BT 898-4)			1	
Trailer, 7t, 4w, antenna mount			1	
Trailer, tractor, crane, M6, 7t			1	
Trailer, 7t, 4w, pole type, flatbed, $\frac{3}{8}$ cu. yd. trk crane attach			1	
Trailer ST, 4w, M23 ammunition			1	
Trailer, 8-, 16-, 20-, and 60-ton, full low bed (when empty)			1	
Trailer, 22t, 6w, low bed			1	
Trailer, 45t, 12w, transporter, Mg			1	
Trailer, chemical handling, M1			1	
Trailer, dump, motorized, cable operated & pneumatic, $11\frac{1}{2}$ cu. yd. and 13 cu. yd			1	
Trailer, fuel servicing 2w, 600-gal			1	
Trailer, tilting type, searchlight 60 in. 4w, M1			1	
Trailer, van dir, station M259			2	
Trailer, van, fire control, 2t, 4w, M244			2	
Trailer, van launching control, M262			2	
Trailer, van, radar tracking control M258			2	
Trailer, low bed, wrecker, 12t, 4w M269 and M270			2	
Trailer, low bed, 25t, 4w, M172			2	
Trailer, cargo 20t, tracked (ATHEY)			2	
Trailer, 5, 7, and 12t, 2w, van				1
Trailer, 14t, 4w antenna mount				1
Trailer, 20t, cargo, tracked, (model ET 1076-1)				1
Trailer, flat bed guided missile M261				1
Trailer, dropbed antenna mount M260				1
Trailer, transporter 45t, 12w, M9				1
Truck $\frac{1}{4}$ t, 4 x 2 to truck 1t, 4 x 4		1		
Truck, ambulance $\frac{1}{2}$ t, $\frac{3}{4}$ t, 4 x 4, M43 and (1b)			1	
Truck, 1t, 4 x 2 to $2\frac{1}{2}$ t, 4 x 2			1	
Truck, 1t, 4 x 4 to $1\frac{1}{2}$ t, 4 x 4			1	
Truck, tractor, $2\frac{1}{2}$ t, 6 x 4			1	
Truck, prime mover, 2t, 6 x 4, M20 (Diamond T models 980 and 981)			1	
Truck, personnel, cargo $1\frac{1}{2}$ t, 6 x 6 to truck, dump, flat bed 4t, 6 x 6			1	
Truck, tractor 4 to 5t, 4 x 4			1	
Truck, dump, tractor, M425 and M426 5 ton 4 x 2			1	
Truck, ponton tractor 5 to 6t, 4 x 4, COE			1	
Truck, dump, chassis, tractor, 5t, 6 x 6			1	
Truck, gasoline tank, 6t, 6 x 6, 2000 gal			1	
Truck, tractor, 6t, 6 x 6			1	

Table I. Individual Drape Nets—Continued

Type of vehicle or equipment	Size individual drape nets			
	22 ft. x 22 ft.	29 ft. x 29 ft.	36 ft. x 44 ft.	45 ft. x 45 ft.
	No. required per vehicle or equipment			
Truck, fire powered brush, class 30, 4 x 2 and 4 x 4			1	
Truck, fire, powered, pumper, class 325, 4 x 2, 4 x 4, class 500, 4 x 2 class 525, 4 x 2 and 4 x 4, class 530, 6 x 6 class 750 4 x 2			1	
Truck, tractor, 20t, 6 x 4 diesel			1	
Truck, gasoline tank 2½t, 6 x 4, 1,250-gal			2	
Truck, amphibian, shop van 2½t, 6 x 6			2	
Truck, cargo, ponton & wrecker, AT, 6 x 6			2	
Truck, chassis, 5t, 6 x 6, M139			2	
Truck, crane, chassis, cargo, heavy wrecker prime mover, 6t, 6 x 6			2	
Truck, prime mover 7½t, 6 x 6			2	
Truck, tractor, 12t, 6 x 6, M26 and M26A1			2	
Truck, cargo, 2½t, 6 x 4				1
Truck, surgical & van type body 2½t, 6 x 6				1
Truck, cargo & dump 2½t, 6 x 6				1
Truck, 5t, 4 x 2				1
Truck, dump body 10 cu. yd. 4 x 2 (2DT)				1
Truck, ponton tractor, 5 to 6t, 4 x 4				1
Truck, prime mover 12t, 6 x 4, M20				1
Truck, 4t to 12t, 6 x 6				1
Vehicle, armored, full track, T18E1; utility, M39; and tank recovery, medium M74			1	
Vehicle, tank recovery M-32 series and heavy M51			2	
Wagon, dirt or rock, crawler mtd 11 cu. yd			1	
Water, purification equip. set No. 3 portable 35 gpm				1

Section II. CAMOUFLAGE NET SETS, FIELD AND ANTI-AIRCRAFT ARTILLERY, DRAPE

3. General

These camouflage net sets, drape, are designed with quick-opening embrasures to satisfy the firing requirements of all artillery weapons. Each net set is so designed that the embrasures can be partially opened and the set remain standing (fig. 222); or the embrasure can be fully opened and the net set dropped (fig. 223). The former method is used for normal field artillery during firing and the latter is used for 360° anti-aircraft artillery firing. These net sets can be easily adapted to conceal either field or anti-aircraft artillery. In order to facilitate the erection of these net sets, personnel should become familiar with the parts of the net sets that effect erection. These

parts are illustrated in figures 224, 225, and 226. The component parts of the net sets covered in this section are interchangeable between the net sets with the exception of nets which vary in size and structure. However, these nets are interchangeable within the net set. (For information on component parts, see table II.) The net sets covered in this section can be erected by 1 leader and 8 men in approximately 18 minutes during daylight hours. During the hours of darkness an additional 15 minutes is required.

Table II. Consolidated Component Parts List of Camouflage Net Sets, Drape

Nomenclature descriptions	Camouflage net sets; field and antiaircraft, artillery, drape;			
	72 ft. w 88 ft. lg	58 ft. w 58 ft. lg	44 ft. w 44 ft. lg	34 ft. w 35 ft. lg
	No. of each required			
Box, pole carrying, 4 ft. 4 in. x 7½ in. x 6 in. deep	3	2	1	1
Net, camouflage, cotton twine, commercial No. 18 to 24, with hardware and fabric garnishment*	^a 4	^b 4	^c 4	^d 2
Support, camouflage-net, steel pole 4 ft. 3 in.	90	60	30	30
Pin, tent, wood, olive drag, 24 in.	100	40	40	40
Net release cable, wire rope, ½-in. dia, w/pins	8	4	2	2
Rope, camouflage net, cotton-braided, guy, ¼-in. dia x 55 ft. long	6	4	2	2
Maul, wood, with 36-in. handle, 6- x 8-in. head	2	2	2	2
Strap, artillery mounting, cotton web, for camouflage sets:				
2 in. x 108 in.	10	6	6	4
2 in. x 72 in.	2	2	2	2
Cap, camouflage net, supporting, round, 20 in. dia.	40	20	15	15
Bag, camouflage net, canvas carrying	5	3	3	2

* Interchangeable within net set only.

^a 36 ft. x 44 ft. (size of each net).

^b 29 ft. x 29 ft. (size of each net).

^c 22 ft. x 22 ft. (size of each net).

^d 17 ft x 35 ft. (size of each net).

4. Camouflage Net Set, Field Artillery, Drape (72 Feet Wide x 88 Feet Long)

a. General. This camouflage net set consists of 4 pregarnished 36 x 44-foot cotton twine nets placed together to form a rectangle 72 x 88-feet long. The total area of the set is 6,336 square feet. The area of effective concealment is somewhat less due to the garnishing thin-out area and the height of the net. The nets are held rigidly in place by 30 guyropes attached at intervals to the outer edge and anchored to wooden stakes. Tent slips on the guyropes make it possible to adjust tension on the net set. The net set weighs 1,065



Figure 222. Embrasure partially opened for firing.

pounds and has a cubage of 60 cubic feet. It is packaged and carried in 5 canvas bags and 3 carrying boxes. Component parts for the net set are listed in table II. The following equipment can be concealed by this net set:

- (1) Gun 120-mm AA.
- (2) Gun 90-mm AA.
- (3) SCR 584.
- (4) Radar tracking station for Corporal.
- (5) Antiaircraft fire control system M-33 series (less augmentation antenna assembly).

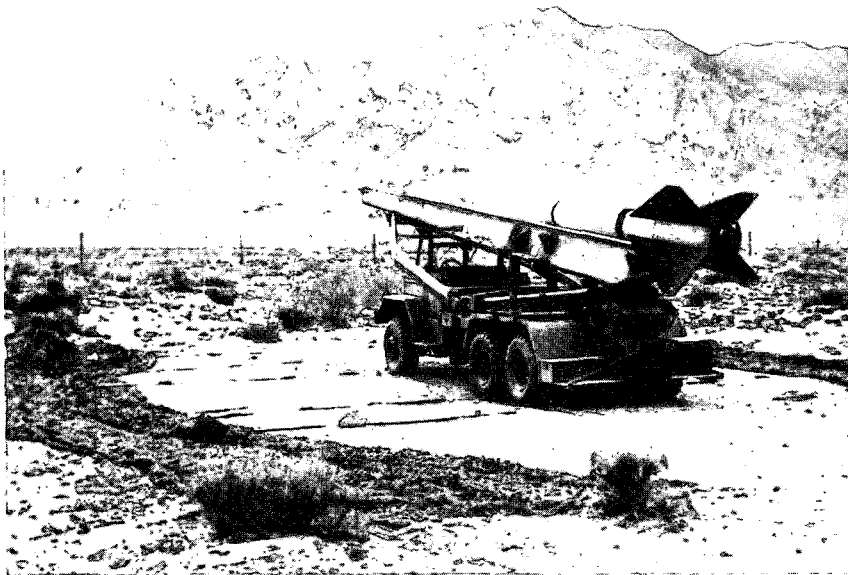

Figure 223. Embrasure fully opened for firing.

b. Methods of Erection. The net set can be erected with or without equipment in place. In the latter method the net set can be propped up and the equipment emplaced upon completion of erection. An erection crew of 1 leader and 8 men should be selected. Steps in the erection of the set are as follows:

- (1) Rolled nets should be placed in proper location, with poles and caps close to weapon (fig. 227).
- (2) Nets should now be opened so that inside corners are close to center of weapon and embrasure edges are facing each other (fig. 228).
- (3) To place the nets in proper position one of the front nets is pulled over the weapon tube by using the inner guyropes as illustrated in figure 229.

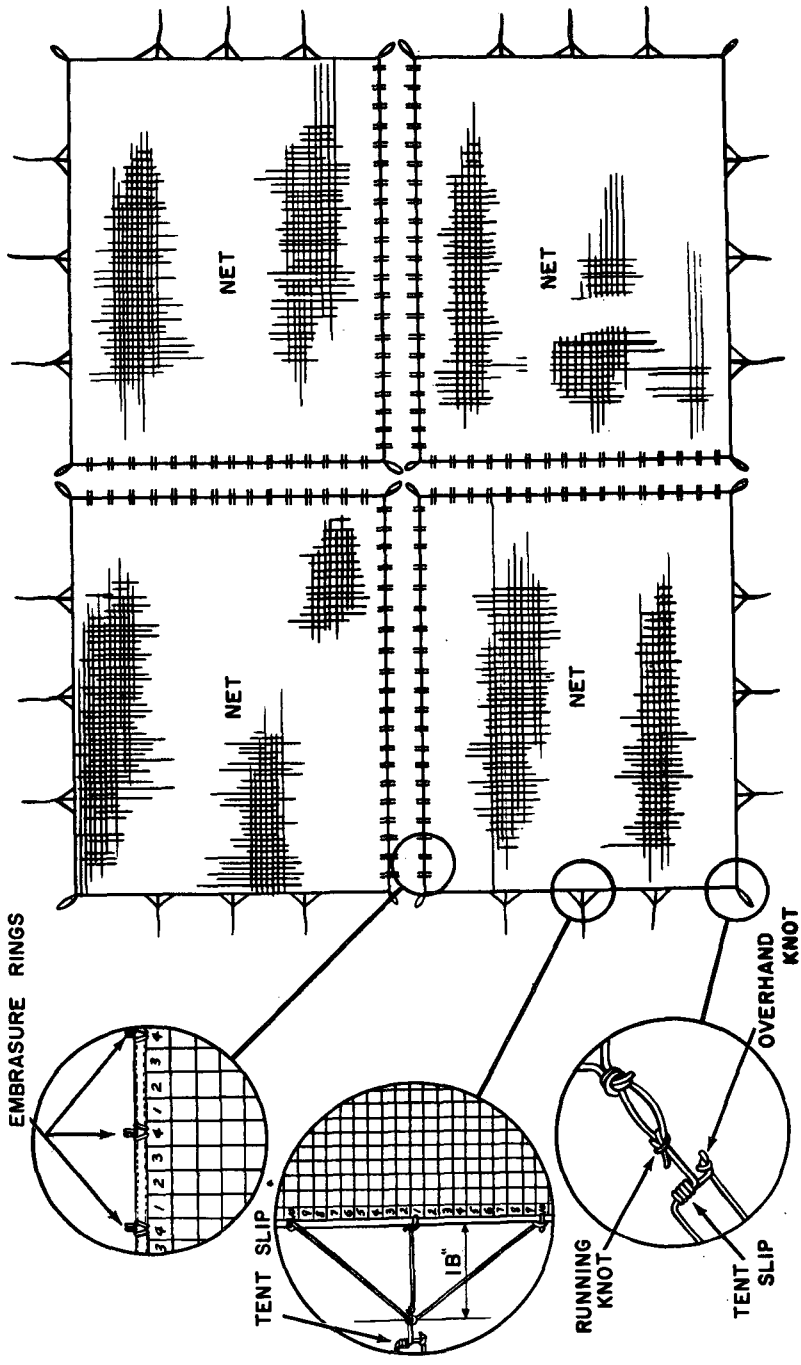

Figure 224. Component parts of nets.

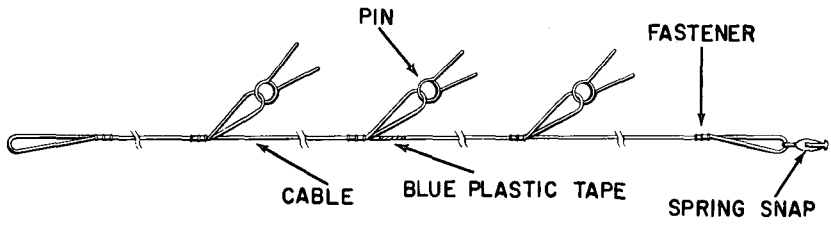

Figure 225. Net release cable.

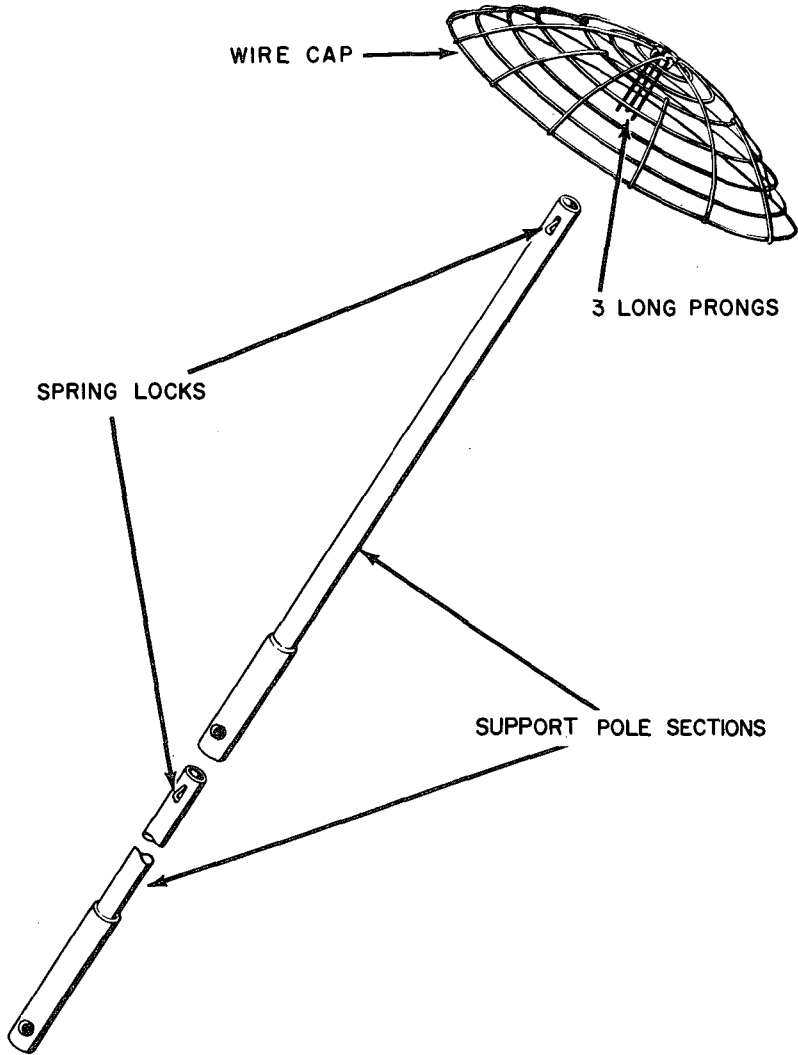
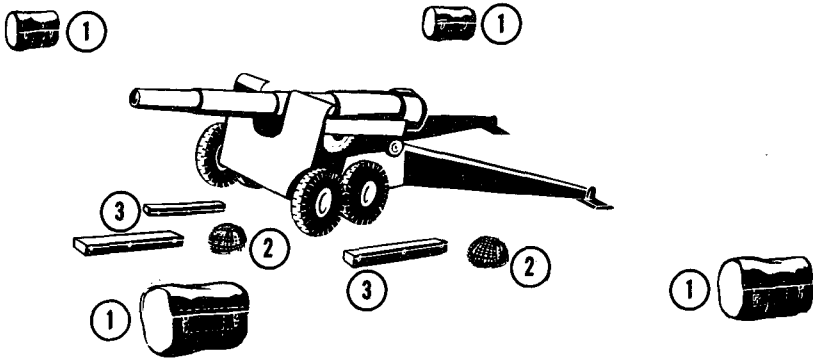

Figure 226. Support and cap assembly details.



- 1 Nets
- 2 Caps
- 3 Support poles

Figure 227. Placement of nets and components to facilitate erection.

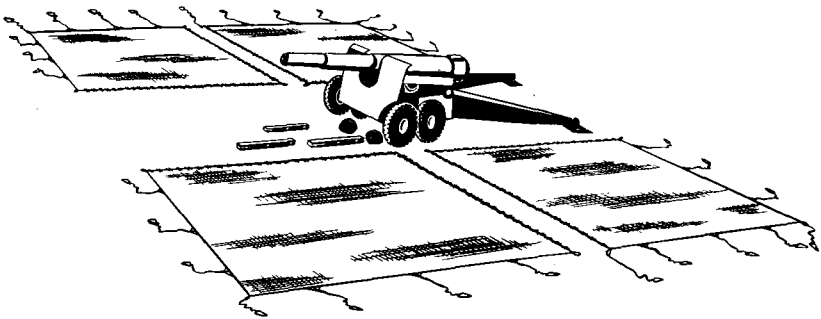

Figure 228. Nets opened.

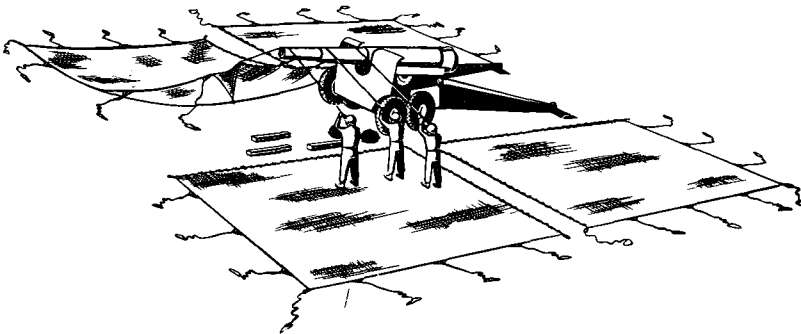

Figure 229. Using inner guyropes to pull net over weapon tube.

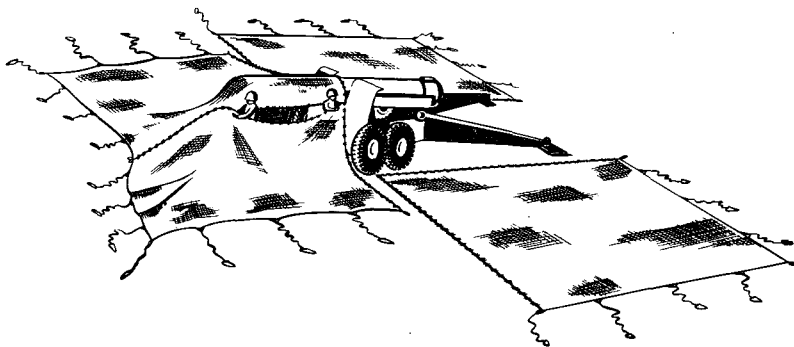

Figure 230. Connecting embrasure edges.

- (4) The next step is to pull the embrasure edges together (fig. 230) and at the same time the color code markers should be matched. The color code markers are red and blue and are located along the embrasure edges. Their purpose is to aid in matching up the nets to facilitate the connecting of the nets together to form the embrasure. The red color code markers indicate the net release cable length along the embrasure. The blue color code markers indicate the midpoint of the net release cable along the embrasure edge. The midpoint of the net release cable is also color coded blue (fig. 225). The nets are now pinned together by inserting the first pin of the net release cable through the first ring of adjoining embrasure edges (fig. 231). This action forms the quick-opening embrasure. To speed up closing the embrasure

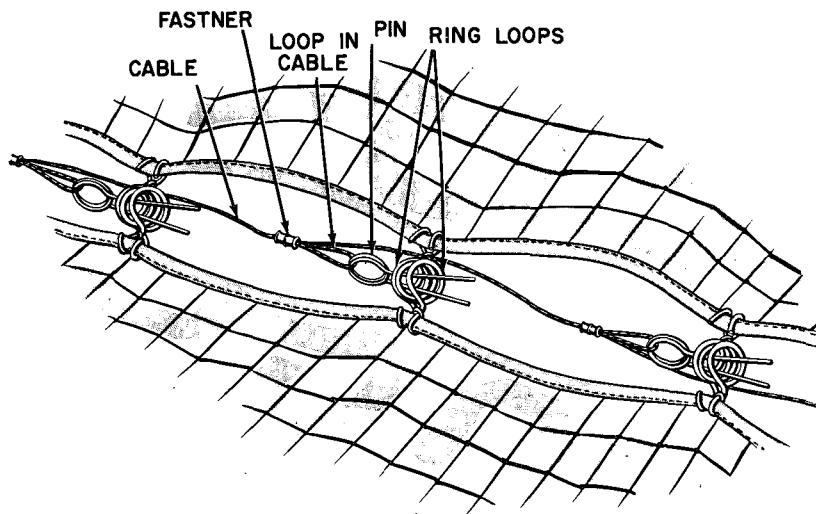

Figure 231. Details of embrasure connections.

match up the blue color marker on net release cable with the blue color code marker on the embrasure edges. The net release pin nearest the blue color code marker should be inserted into the adjoining rings closest to the blue color code marker along the embrasure edge. The remaining pins are inserted in a like manner and this operation is continued until the embrasure is completely closed. For artillery weapons the pins should be pointed away from center of net set. For antiaircraft weapons the pins should be pointed toward the center of the net set.

- (5) The 2 rear nets are connected to one another using the procedures described in the previous step. In a like manner the front nets are connected to the rear nets (fig. 232). Guyropes should now be extended to $\frac{3}{4}$ length and a stake placed by each guyrope (fig. 232).

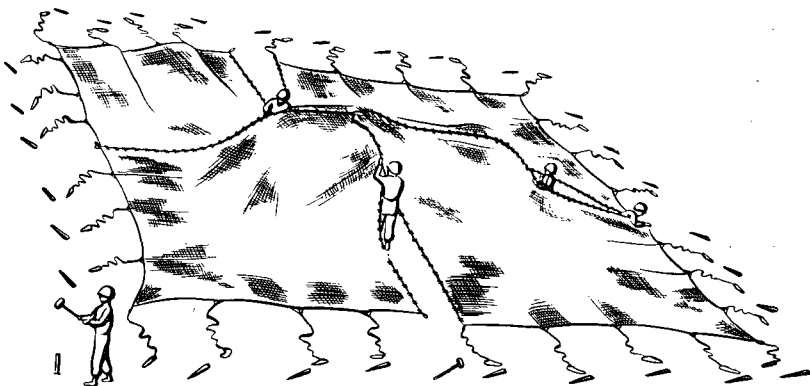

Figure 232. Connecting rear nets and front nets.

- (6) The four corner guyropes should be pulled taut, stakes driven, and guyropes looped over stakes and adjusted (fig. 233). At the same time the front and rear embrasures should be centered over the highest point of the weapon (fig. 233). Stakes should now be driven for the other guyropes.
- (7) Supports should now be assembled to required length and caps inserted in the upper section (fig. 226). (See (9) below, for length requirements). Supports should be located at various positions under the nets to support the net uniformly and at the same time to disrupt the shape of the net and eliminate any straight line effect. The supports must be leaned away from the weapon to aid in dropping the nets when embrasure is opened (fig. 234).

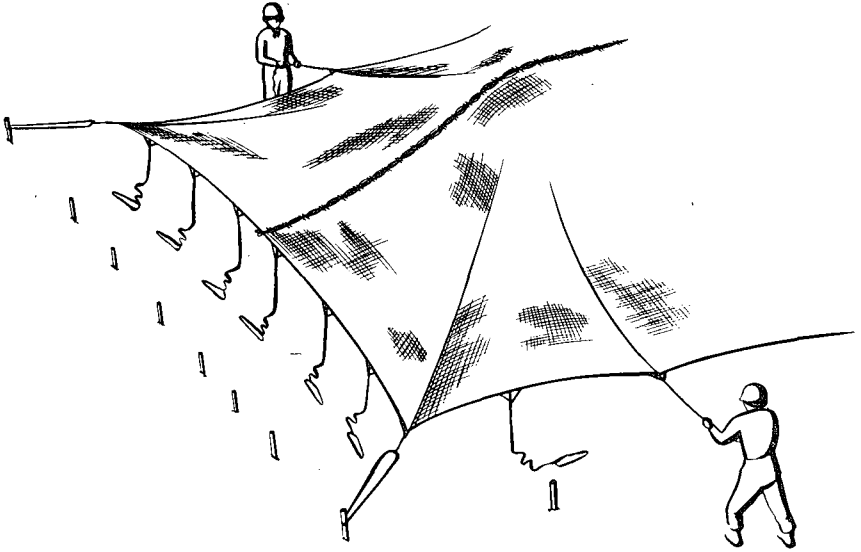

Figure 233. Corner guyrope detail and centering net set over highest point of weapon.

- (8) To minimize the billowing of the net set during high winds and to keep the net set erect when one embrasure is opened, inner guyropes are attached to the front and rear nets. This is accomplished by snapping inner guyropes to reinforcement tape on the front and rear nets at the side embrasure (fig. 235). Stakes to anchor the inner guyropes are now located and driven toward each corner of the net set as illustrated in figure 235. Inner guyrope is now looped over stakes and adjusted.
- (9) Supports should now be placed so that net is a minimum of 3 feet above the highest point of the weapon. For anti-aircraft weapons, supports should be located outside of emplacement pit (fig. 236). Net set should be adjusted so that it presents an irregular shape and a low silhouette (fig. 237).

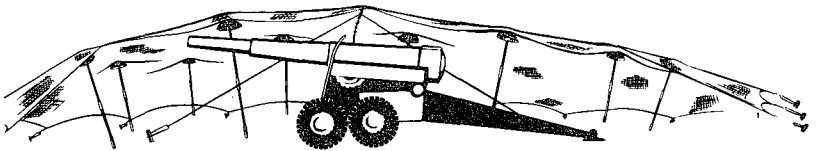

Figure 234. Supports leaned away from weapon.

c. Preparation of Position for Firing.

- (1) To drop nets for firing anti-aircraft artillery, the ends of the two net release cables, which are located at the outside edges of each embrasure, are pulled simultaneously (figs. 223 and 238). To reerect the net set all guyropes are unhooked and the erection procedures outlined in *b* above, are repeated.
- (2) To open an embrasure for field artillery firing, the net embrasure release cable suspended at the center of the net set

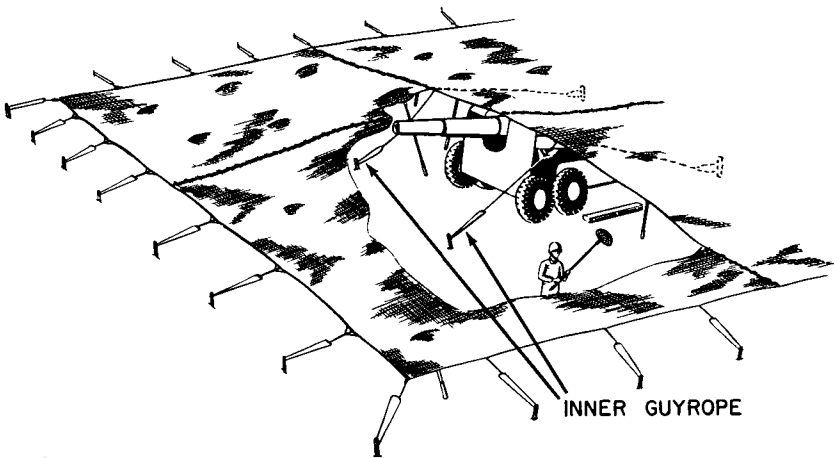

Figure 235. Inner guyrope details.

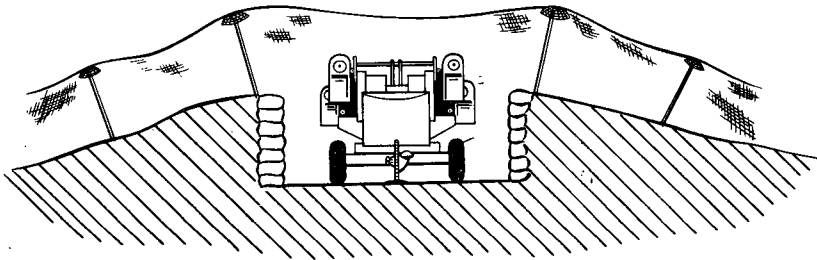

Figure 236. Supports outside emplacement pit for anti-aircraft weapons.

is pulled. This action opens the forward embrasure and the remainder of the net set remains erect (fig. 222). To close this embrasure follow the procedures outlined in *b*(3) and (4) above.

5. Camouflage Net Set, Field Artillery, Drape (58 Feet Wide x 59 Feet Long)

a. General. This net set is identical in design to the net set covered in paragraph 4, except that it is smaller. This net set is equipped



Figure 237. Completely erected net set, with desired irregular shape and low silhouette.

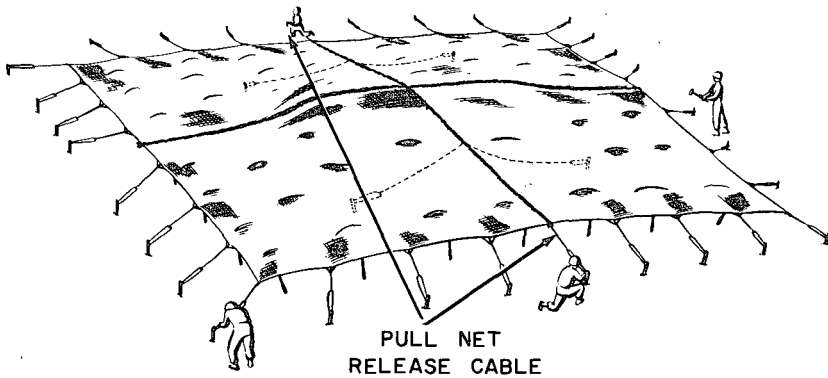

Figure 238. Location of the end of two net release cables.

with 4 garnished 29- by 29-foot cotton twine nets placed together to give an overall dimension of 58 feet by 58 feet, with a total area of 3,364 feet. The net set weighs 648 pounds and occupies 34 cubic feet. It is packaged and carried in 3 canvas bags and 2 carrying boxes. Component parts of this net set are listed in table II. The following equipment can be concealed by this net set :

- (1) Gun, 75-mm, AA, T-69 series.
- (2) Howitzer, 155-mm, towed.
- (3) Howitzer, 105-mm, towed.
- (4) SCR 784.

b. Methods of Erection. The procedures outlined in paragraph 4*b* and *c* should be followed.

c. Preparation of Position for Firing and Reerection of the Net Set.

- (1) The procedures outlined in paragraph 4*c*(1) and (2) should be followed.
- (2) To open an embrasure for field artillery firing, the release cable suspended at the center of the net set is pulled. This action opens the forward embrasure and the remainder of the net set remains erect. To close this embrasure the procedures outlined in paragraph 4*b*(3) and (4) should be followed.

6. Camouflage Net Set Antiaircraft Gun, Drape, (44 Feet Wide x 44 Feet Long)

a. General. This net set is similar in design to the 2 net sets covered in paragraphs 4 and 5. The nets are smaller in size and only 1 quick-opening embrasure extends from front to rear. The front nets are connected to the rear nets by lacing loops. The net set consists of 4 garnished 22- by 22-foot cotton twine nets placed together to give an overall dimension of 44 feet by 44 feet or 1,936

square feet. The area of effective concealment is somewhat less due to the garnishing thin-out area and the height of the erected net set. The net set weighs 367.5 pounds and occupies 21.5 cubic feet. It is packaged and carried in 3 canvas bags and 2 carrying boxes. The component parts of this net set are listed in table II. The following equipment can be concealed by this net set:

- (1) Gun, 40-mm, M-2 series.
- (2) Carriage, motor, twin, 40-mm gun, M14A1.
- (3) Carriage motor combination, M-15 series.
- (4) Carriage motor multiple, MGM-16 series 308-1-26.

b. Erection. This net set should be erected after the weapon is in place. The erection procedures outlined in paragraph 4b(1) and (2) should be followed initially. Then the front nets should be connected to the rear nets by lacing the loops. Completion of this operation forms a single net on each side of the weapon. Lacing the front nets to the rear nets is accomplished with 9-inch loops of 1/8-inch cotton sash cord attached at intervals of 4 meshes on the rear edge of the front nets. Lacing is begun by extending the end loop of the front net diagonally across and through a mesh in the rear net, leaving the end of the loop hanging free. The next loop is inserted through the loose end of the previous loop and then diagonally across to the rear net and back again to the front net, once again allowing the loop end to hang free. This process is repeated across the width of the net and the end of the last loop is tied securely to the outer edge of the net. Then the procedures outlined in paragraph 4b(3) through (9) should be followed for completion of erection.

c. Preparation of Position for Firing and Reerection of Net Sets. The procedures outlined in paragraph 4c(1) and (2) should be followed.

7. Camouflage Net Set, Antiaircraft Machinegun, Drape (34 Feet Wide x 35 Feet Long)

a. General. This net set is similar in design to the other net sets discussed in this section except that it consists of only 2 garnished 17-x 35-foot cotton twine nets placed together to give an overall dimension of 34 x 35 feet, having a total area of 1,190 square feet. The area of effective concealment is somewhat less due to the garnishing thin-out area and the height of the net set. This net set weighs 306 pounds and occupies 15 cubic feet. It is packaged and carried in 2 canvas bags and 1 carrying box. The component parts for this set are listed in table II. The following equipment can be concealed by this net set:

- (1) Mount, trailer, multiple, caliber .50 machinegun, M-55.
- (2) Acquisition antenna assembly of AA FCS, M-33 series.

b. Erection of Net Set. This net set is erected after the equipment is in place. The erection procedures outlined in paragraph 4 are followed except the step in paragraph 4*b*(5) is eliminated.

c. Preparation of Position for Firing and Reerection of the Net Set. The procedures outlined in paragraph 4*c*(1) and (2) should be followed.

INDEX

Access:	Paragraphs	Pages
Paths	75c	113
Routes	74c (2), 85	111, 139
To Runways	99a (2), 102	168, 189
Aerial:		
Inspection	83d	138
Observation	6	6
Agricultural terrain	68	102
Aircraft:		
Camouflage	101	187
Checklist for camouflage	110	197
Covers	106b	194
Insignia	106, 114	192, 202
Parking Sites	99a (1), 102	168, 189
Pattern Painting	111	197
Shine	106	192
Ammunition concealment	80b, 83b	131, 137
Angles of view	8a	10
Artificial materials	12d, 17, 27	27, 35, 45
Artillery	82	137
Bacteria in soils	46	68
Barren terrain	35c, 70, 78c	54, 104, 123
Bivouacs	72	110
Blast area	96	162
Blending:		
Artificial materials	12d, 17	27, 35
Camouflage	11e (2)	19
With background	21, 50	39, 73
With terrain	86	140
Bow-ties	28, 45b	47, 66
Buggy-top	116b	204
Building tonedown	99b (2), 99e, f	176, 179
Camouflage:		
Blending	11e (2)	19
Clothing	48	70
Color characteristics	11e (3)	20
Construction	12c, 57	27, 83
Covers	58	93
Definition	3	3
Discipline	12b	24
Helmet	45	64
Importance of	3	3
Inspection	83d	138
Methods	13	28
Responsibility	5	5

	Paragraphs	Pages
Canvas equipment.....	47	70
Charcoal.....	46, 47, 78	68, 70, 119
Checklist of aircraft camouflage.....	110	197
Clothing.....	48	70
Color.....	11e	19
Command posts.....	79	123
Component parts of net sets, drape.....	App. II	227
Composition of drape net sets.....	31	49
Concealment.....	12	24
Ammunition.....	80b, 83b	131, 137
Blast areas.....	96	162
Combat.....	19	36
Desert.....	16, 70	32, 104
During movement.....	53, 62, 94	75, 96, 157
Individual.....	42	59
Jungle.....	18	36
Practices snow.....	23	39
Supplies.....	82a	137
Tracks.....	12b, 61, 71b, 75d	24, 96, 104, 116
Vehicles.....	60	96
Weapons individual.....	59	94
Wooded areas.....	67	101
Construction, camouflage.....	12c; 57	27, 83
Controlled mowing.....	25b (1), 99b	42, 171
Corps of Engineers responsibility.....	5c	5
Cover, emplacement.....	57b	89
Cover, foxhole.....	57a	89
Covers, aircraft.....	106b	194
Cut vegetation.....	25c	44
Debris.....	25d	45
Deceiving.....	13c	28
Deception.....	3b, 4d	4, 5
Decoys.....	13c, 22	28, 39
Desert areas.....	16, 56c, 70, 78c, 88d, 102d, 35, 94, 109	32, 82, 104, 123, 148, 190, 51, 157, 195
Differences in tone.....	11e(2)	19
Direct observation.....	6a, 7	6, 8
Discipline:		
Camouflage.....	12b, 79c	24, 125
Night.....	12b (2)	26
Water points.....	81d	136
Dispersion:		
Aircraft.....	104	191
As a means of camouflage.....	4a	4
Factors.....	4b	4
Tents.....	75b	113
Troops.....	4c	4
Vehicles.....	63	96

	Paragraphs	Pages
Disruption of form.....	39	55
Disruptive pattern:		
Aircraft.....	111c	198
Artillery.....	92	151
Vehicles.....	41d	57
Drape net sets.....	30	48
Drape net sets, composition.....	31	49
Drape nets.....	29	48
Earths:		
Earth.....	25e (1)	45
Gravel.....	25e (3)	45
Sand.....	25e (2)	45
Embrasures.....	31	49
Emplacements.....	55	79
Covers.....	57	83
Erection of Camouflage net sets, drape.....	App. II	227
Expedients.....	116	204
Factors:		
Concealment.....	16	32
Dispersion.....	4b	4
Geographic areas.....	14	32
Recognition.....	11	14
Field service installations.....	80, 81	131, 133
Films types of.....	9	11
Black and white.....	9a	11
Color.....	9b	11
Camouflage detection.....	9d	13
Infrared.....	9c	12
Narrow-band.....	9d	13
Flattop net for machine gun.....	116a	204
Flattop net sliding cover AA gun.....	116i	210
Flattop nets.....	32	50
Height of.....	33	51
Maintenance of.....	34	51
Materials for.....	27d, 27b, 32	46, 45, 50
Procedures for erection.....	116	204
Form, disrupting of		
General.....	39	55
Helmets.....	45a	66
Garnishing		
Artificial material.....	27c	46
Bow-tie.....	28, 45b	47, 66
Color blends.....	28	47
Natural material.....	24, 25	42
Patterns.....	28	47
Guided missiles.....	93	157
Blast area.....	96	162
Painting.....	97	163
Siting.....	95	158
Grasses.....	25b	42
Gravel.....	25e (3)	45
Grease.....	48	70
Ground observation:		
Direct.....	6a	6
General.....	6	6

	Paragraphs	Pages
Helicopters.....	101	187
Helmet, camouflage.....	45	64
Hiding.....	13a	28
High oblique.....	8a (2)	10
Igloo.....	116e	207
Indirect observation.....	6b	7
Individual.....	42	59
Blending.....	50	73
Camouflage in jungle areas.....	44b	61
Camouflage in snow areas.....	44c	62
Snow suits.....	49	72
Concealment.....	42	59
Insignia army aircraft.....	106	192
Landing site.....	98	164
Lampblack.....	46	68
Live vegetation use of.....	25a	42
Logistical data nets and net sets, drape.....	App. II	227
Machinegun, flattop.....	116a	204
Maintenance:		
Artificial materials.....	37	55
Natural materials.....	25c	44
Nets, drape.....	App. II	227
Nets, flattop.....	32e	51
Markings of aircraft.....	114	202
Methods, basic.....	12	24
Mountain areas.....	20a	38
Movement.....	11f	20
Mowing, controlled.....	25b (1), 99b	42, 171
Mud.....	46, 59	68, 94
Natural materials:		
Maximum use.....	12c	27
Use in camouflaging individual.....	50, 53	73, 75
Use in camouflaging weapons.....	59	94
Use in camouflaging vehicles.....	64	96
Nets:		
Drape (individual).....	29, 117	48, 214
Drape (net sets).....	30, App. II	48, 227
Flattops.....	32	50
Net release cable.....	App. II	227
Night action.....	52	74
Nuclear.....	2b	3
Observation:		
Aerial.....	6	6
Enemy.....	43	60
Ground.....	6a, b	6
Posts.....	91	151
Painting:		
Aircraft.....	111	197
Artillery field.....	92	151
Disruptive.....	39	55
Helicopters.....	111	197
Helmet.....	45a	66
Missile.....	97	163
Vehicles.....	39, 41d, 78b (2)	55, 57, 121

	Paragraphs	Pages
Parking sites for aircraft.....	99a (1), 102	168, 189
Pattern painting:		
Aircraft.....	111	197
Artillery.....	92	151
Helmets.....	45a	66
Individual weapon.....	58	93
Vehicles.....	39, 41d, 78b (2)	55, 57, 121
Patterns:		
Garnishing.....	28	47
Terrain.....	15	32
Photointerpreter.....	8b	10
Planning:		
Airfield camouflage.....	99, 100	168, 183
Bivouacs.....	74	110
Track.....	61, 74c (2), 75d, 85	96, 111, 116, 139
Protective area of a flattop.....	34	51
Responsibility:		
Camouflage.....	5	5
Roads:		
Access.....	53, 85	75, 139
Concealed.....	62, 99a (2)	96, 168, 171, 189
Taxiways.....	99b (1), 102	171, 189
Sand.....	25e (2)	45
Screens.....	35, 62	51, 96
Seasonal changes.....	15	32
Shadow.....	11c, 50, 65, 99d, e	15, 73, 101, 178
Shadow nets.....	107	194
Shadows, vehicle.....	65	101
Shine.....	11g	20
Siting:		
Aircraft.....	102	189
Artillery battery.....	83	137
Equipment.....	66	101
Field fortifications.....	56	80
Guided Missile battery.....	95	158
Silhouettes.....	40, 50, 51	56, 73
Skin tonedown.....	44a, 46	68
Sliding cover.....	116d	207
Smoke.....	36	54
Snow:		
Areas.....	20, 56e, 71, 78b, 87f, 88d, 102b	38, 82, 104, 120, 145, 148, 189
Blending with.....	21	39
Concealment practices.....	23	39
Individual camouflage.....	44c	62
Suits.....	49	72
Sound:		
Control.....	12b (3)	26
Ranging.....	12b (3)	26
Spoil.....	30b, 57a	49, 89

	Paragraphs	Pages
Staff responsibilities for camouflage.....	5b	5
Swinging flattop.....	116c	205
Terrain:		
Agricultural.....	68, 78a, 87b, 88b, 102c	102, 119, 140, 147, 189
Desert.....	16, 56c, 70, 78c, 88d, 102d	32, 82, 104, 123, 148, 190
Snow.....	20, 44c, 56e, 71, 78b, 87f, 88d, 102b	38, 62, 82, 104, 120, 145, 148, 189
Urban.....	69, 87c, 88c	102, 143, 148
Wooded.....	57b, 67, 88a, 102a	89, 102, 147, 189
Texture.....	11d	15
Texturing.....	11d, 99b (2)	15, 176
Tone, differences.....	11e (2)	19
Toning down:		
Earth scars.....	93, 96	157, 162
Grass.....	25b (2), 99b (2)	43, 176
Skin.....	46	68
Weapons individual.....	59	94
Tracks.....	12b, 61, 71b, 75d	24, 96, 104, 116
Training camouflage.....	98b	164
Truck park.....	79c	125
Twine nets.....	27d (2)	46
Urban terrain.....	69, 87c, 88c	102, 143, 148
Vehicles camouflage in general.....		
By dispersion.....	60	96
During movement.....	63	96
During movement.....	62	96
In snow areas.....	71	104
Vegetation:		
Vines, use.....	116a	204
Visual deception.....	10, 13c	14, 28
Weapons tonedown.....	59	94
Wooded terrain.....	57b, 67, 88a, 102a	89, 102, 147, 189

[AG 300.7(22 Oct '58)]

By Order of *Wilber M. Brucker*, Secretary of the Army:

MAXWELL D. TAYLOR,
General, United States Army,
Chief of Staff.

Official:

R. V. LEE,
Major General, United States Army,
The Adjutant General.

Distribution:

Active Army:

DCSLOG (2)	17 (2), 5-36 (5), 5-37 (2), 5-
Technical Stf, DA (2)	56 (5), 5-67 (2), 5-96 (10),
USCONARC (10)	5-97 (5), 5-192 (3), 5-217, 5-
USA Arty Bd (2)	218 (2), 5-226 (3), 5-227, 5-
USA Armor Bd (2)	262, 5-266 (2), 5-301, 5-312
USA Inf Bd (2)	(5), 5-316 (3), 5-317, 5-346,
USA Air Def Bd (2)	5-356, 5-359, 5-367 (2), 5-526
USA Abn & Elet Bd (2)	(5), 5-527, 6-100, 6-200, 7-52,
USA Avn Bd (2)	11-54, 17-2, 17-51 (2), 55-57,
US ARADCOM (2)	55-58, 57-5 (5)
US ARADCOM, Rgn (2)	USMA (10)
OS Maj Comd (10)	Svc Colleges (2)
OS Base Comd (2)	Br Svc Sch (2) except USAES
Log Comd (2)	(462)
MDW (2)	Trans Terminal Comd (2)
Armies (10)	Div Engr (1)
Corps (5)	Engr Dist (1)
Div (10)	Mil Dist (1)
Bn (1) except TOE's:	Sector Comds (Res) (1)
5-15 (5), 5-35 (2), 5-55, 5-215,	USA Corps (Res) (1)
5-225, 5-315 (5), 5-355 (3),	Units organized under following
5-525 (5)	TOE's:
CO (1) except TOE's:	20-300 (1)
1-7, 1-17, 1-57, 1-67, 1-107, 1-	29-500 (HA, EB, EC, ED, EE,
117, 1-127, 1-137, 5-16 (5), 5-	EF, EG) (1)

NG: State AG (3): units—same as Active Army except allowance is one copy to each unit.

USAR: None.

For explanation of abbreviations used, see AR 320-50.